



Ren, Baihua (2020) *The Water Mill: authentication and analysis of an ancient Chinese Jiehua painting*. PhD thesis.

<http://theses.gla.ac.uk/81625/>

Copyright and moral rights for this work are retained by the author

A copy can be downloaded for personal non-commercial research or study, without prior permission or charge

This work cannot be reproduced or quoted extensively from without first obtaining permission in writing from the author

The content must not be changed in any way or sold commercially in any format or medium without the formal permission of the author

When referring to this work, full bibliographic details including the author, title, awarding institution and date of the thesis must be given

Enlighten: Theses

<https://theses.gla.ac.uk/>
research-enlighten@glasgow.ac.uk



University
of Glasgow

Figures of Dissertation

Baihua Ren

M.A. (University of Bristol), 2014

B.A. (Central Academy of Fine Arts), 2013

Submitted in fulfilment of the requirements for the Degree of
Doctor of Philosophy in History of Art

School of Cultural and Creative Arts

College of Arts

University of Glasgow

September 2020



Figure 1
Attributed to Wei Xian (ca. 10th century)
The Water Mill handscroll
Shanghai Museum, Shanghai
(Photo by Zhang Yilin, from *Songhua quanji*, 2-1, 14)



Figure 2

Attributed to Wei Xian (ca. 10th century)

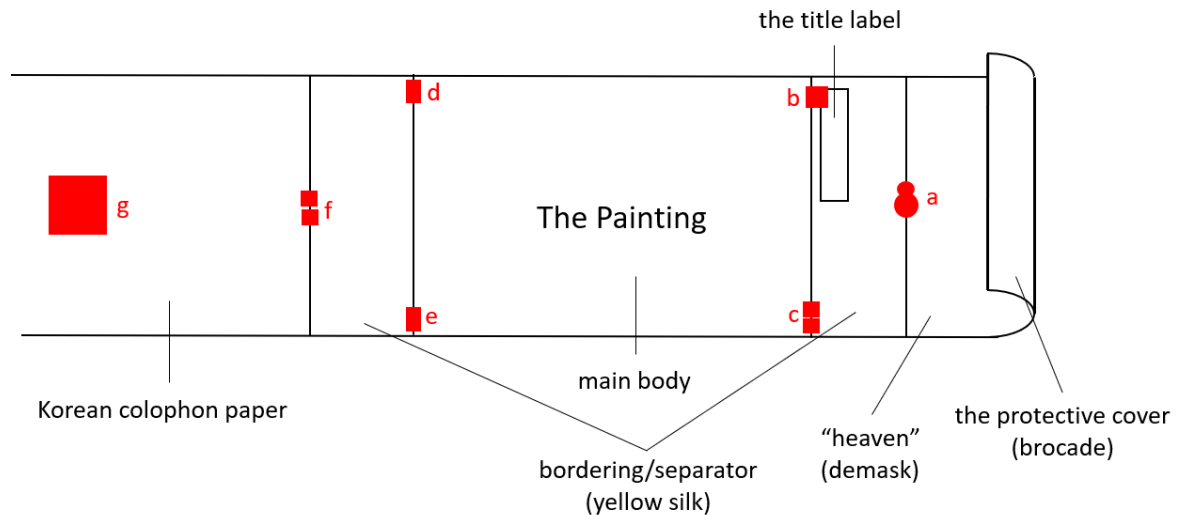
The Water Mill, ink and colours on silk,

55.4 x 124.1 cm,

Shanghai Museum, Shanghai

(Photo by Zhang Yilin, from *Songhua quanji*, 2-1, 14)

The Full *Xuanhe* Mounting Style Scroll



- a. A “Yushu” calabash-shape seal between the Head Section and the Former Bordering.
- b. A square seal showing two Chinese dragons beside the title label by Huizong Emperor, usually between the Former Bordering and the painting.
- c. A “Xuanhe” seal which were constituted of two small seals for each word, at the bottom of the gap between the Former Bordering and the artwork.
- d. A “Zhenghe” rectangular seal at the top between the painting and the Latter Bordering.
- e. A “Xuanhe” rectangular seal at the bottom between the gap of painting and the Latter Bordering.
- f. A “Zhenghe” seal which were constituted of two small seals for each word, stamping between the Latter Bordering and the colophon paper.
- g. A large “Neifu Tushu Zhiyin (Seal of the Official Inventory Collected Paintings and Books)” quadrate seal at the middle of the colophon paper.

Figure 3

The full *Xuanhe* mounting style for a painting handscroll



Figure 4

Detail of *The Water Mill*, the seal “*tianli zhibao* 天曆之寶” and the evaluation “*shenpin shang* 神品上”

(Photo from *Songhua quanji*, 2-1, 15)



Figure 5
Detail of *The Water Mill*
the mutilated signature of Wei Xian
(Photo from ZGHHMP, vol 21)



Figure 6

Attributed to Zhang Zeduan

Along the River During the Qingming Festival

Around 1085-1145, ink and colours on silk

24.8 cm x 528 cm

Palace Museum, Beijing

(Image from www.dpm.org.cn/collection/paint/228226)



Figure 7

Unknown

The Water Mill in Valley

Around the Yuan Dynasty, ink and colours on silk

153.5 cm x 94.3 cm

Liaoning Provincial Museum, Shenyang

(Image from ltfc.net/img/5be1da713d334d1409ccb4b8)

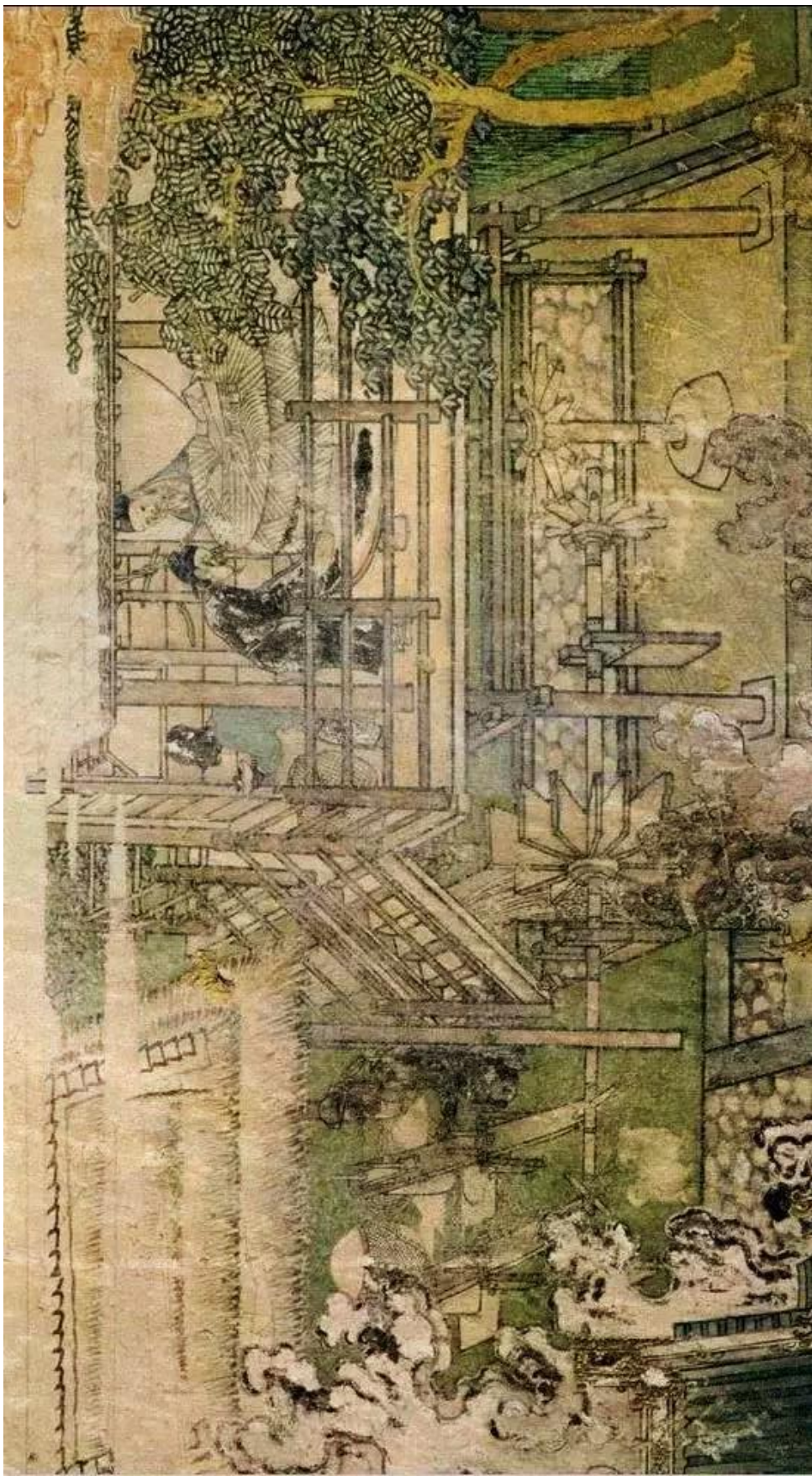


Figure 8
Wang Kui (1100-?) et al.
The Water Trip-Hammer and The Water Mill
mural painting (1158-1167)
Yanshan Temple, Fanshi County, Shanxi province



Figure 9
Wei Xian (ca. 10th century)
Gaoshi Tu
Five Dynasties, ink and colours on silk
134.5 cm x 52.5 cm
Palace Museum, Beijing
(Image from www.dpm.org.cn/collection/paint/234557)



Figure 10
Attributed to Jing Hao
The Mount Lu
About Northern Song, ink on silk
185.8 cm x 106.8 cm
National Palace Museum, Taipei
(Image from painting.npm.gov.tw/Painting_Page.aspx?dep=P&PaintingId=506)



Figure 11
Attributed to Guan Tong
Passing Through Mountains
About Northern Song Dynasty, ink and colours on silk
144.4 cm x 56.8 cm
National Palace Museum, Taipei
(Image from painting.npm.gov.tw/Painting_Page.aspx?dep=P&PaintingId=15)

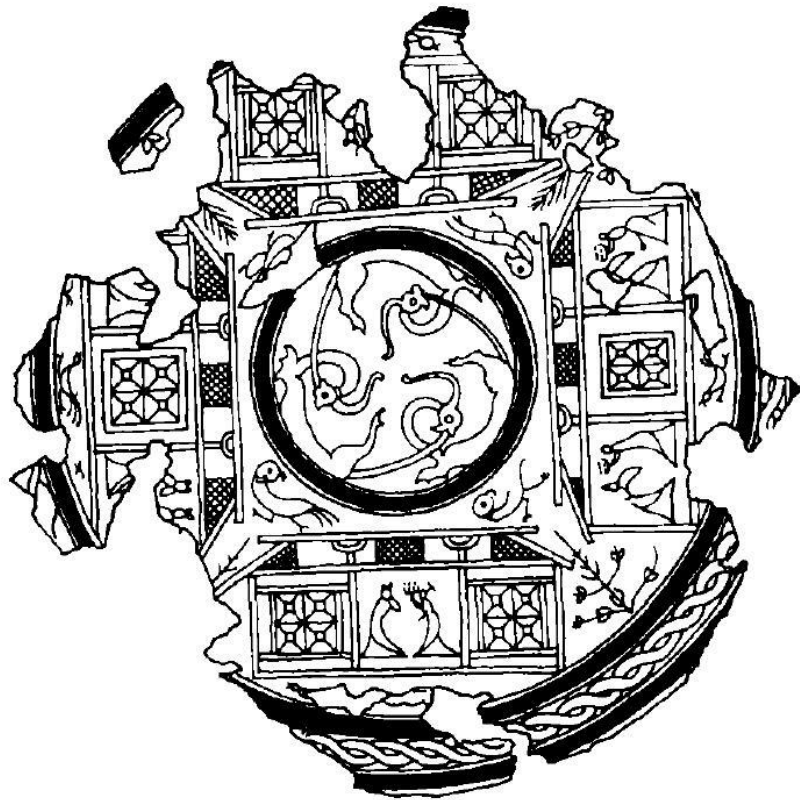


Figure 12
A lacquer painting with architecture image
No. 1 tomb of Langjiazhuang (Eastern Zhou), Linzi, Shandong province
(Image from *Wenwu*, 1998: 3, 75)

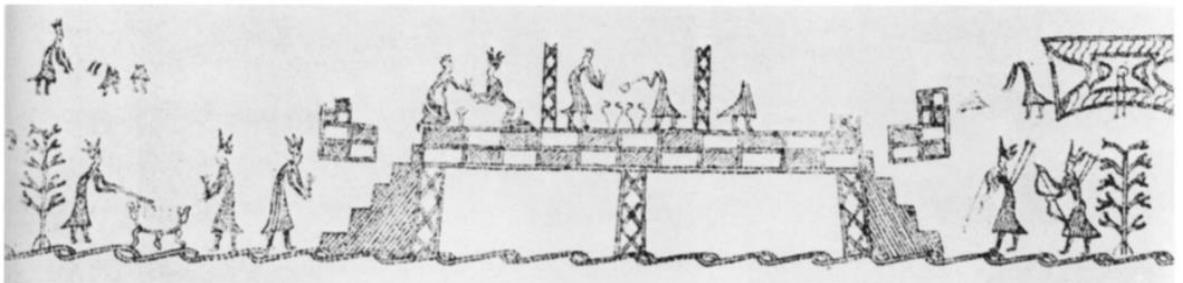
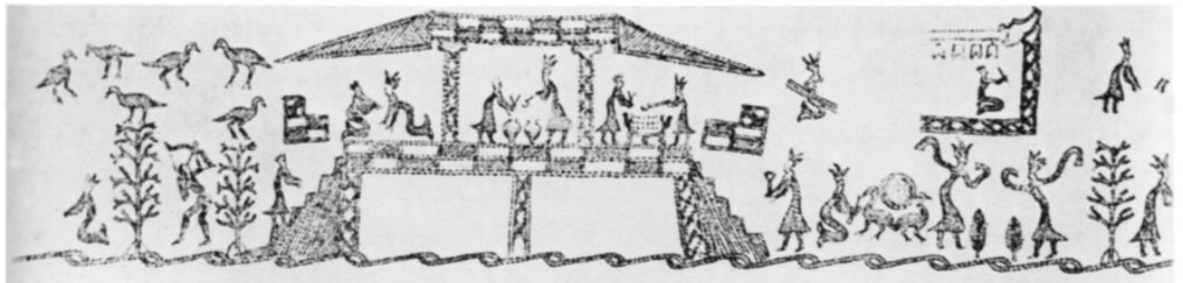


Figure 13
Image inside an oval bronze bowl
Shanghai Museum, Shanghai
(Image from *Wenwu*, 1961: 10, 29)

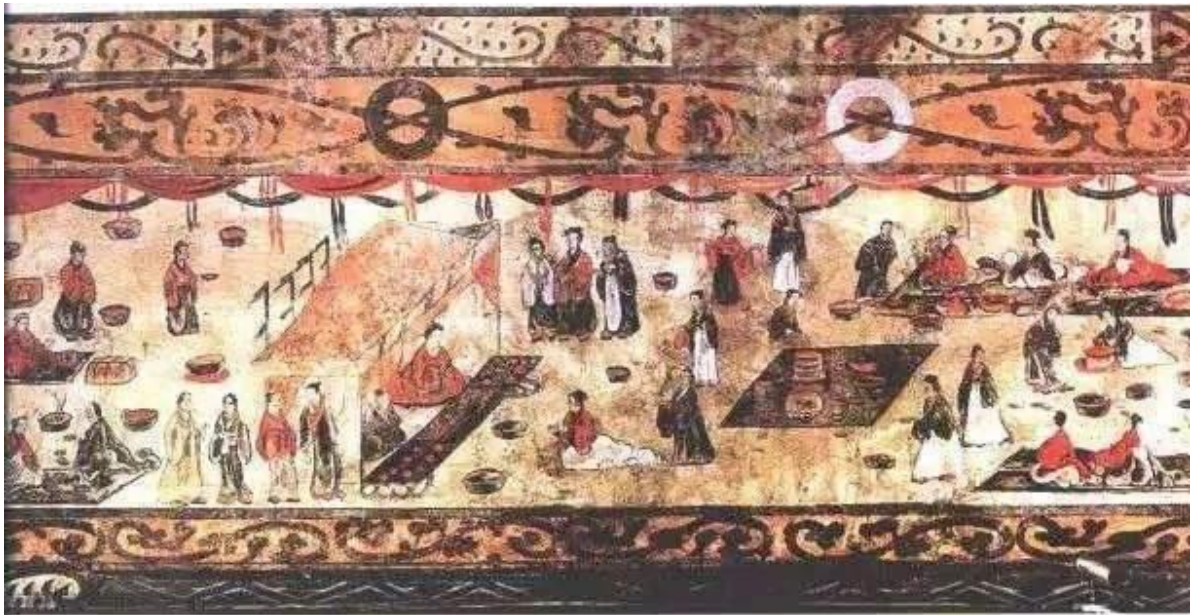


Figure 14

The Banquet Scene (Eastern Han), mural painting
the west tomb M1 of Dahuting Han tombs, Xinmi, Henan province

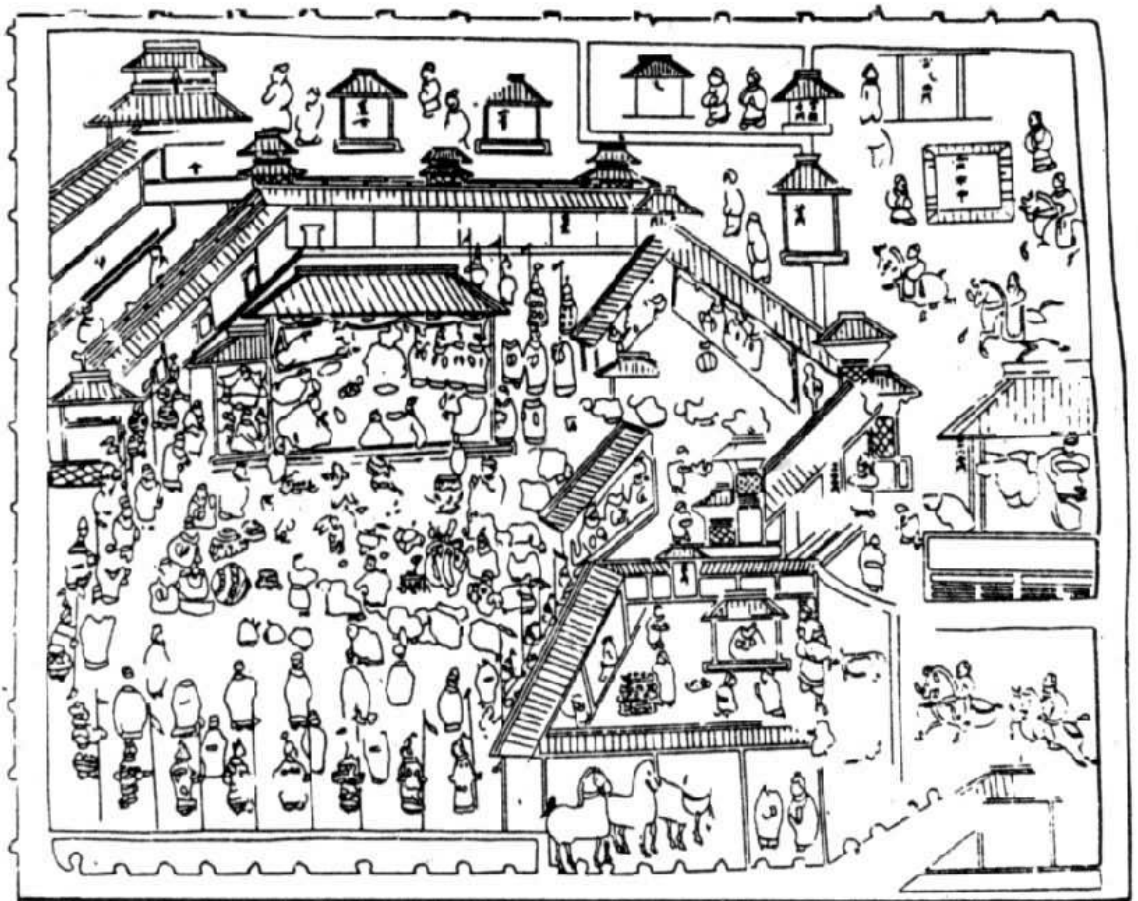


Figure 15

The Ningcheng City, line drawing from mural painting (Eastern Han)
Horinger tomb, Ulanqab, Inner Mongolia Autonomous Region



Figure 16
Pottery structures (Han)
Henan Provincial Museum, Zhengzhou
(Photo by BR)



Figure 17

Western Pure Land Illustration

cave 217, Dunhuang, Gansu province

(Image from *Dunhuang Academy*, "Mogao Crottoes, 217 cave, the glorious age of Tang Dynasty", tour.dha.ac.cn/content.aspx?id=596635627595)

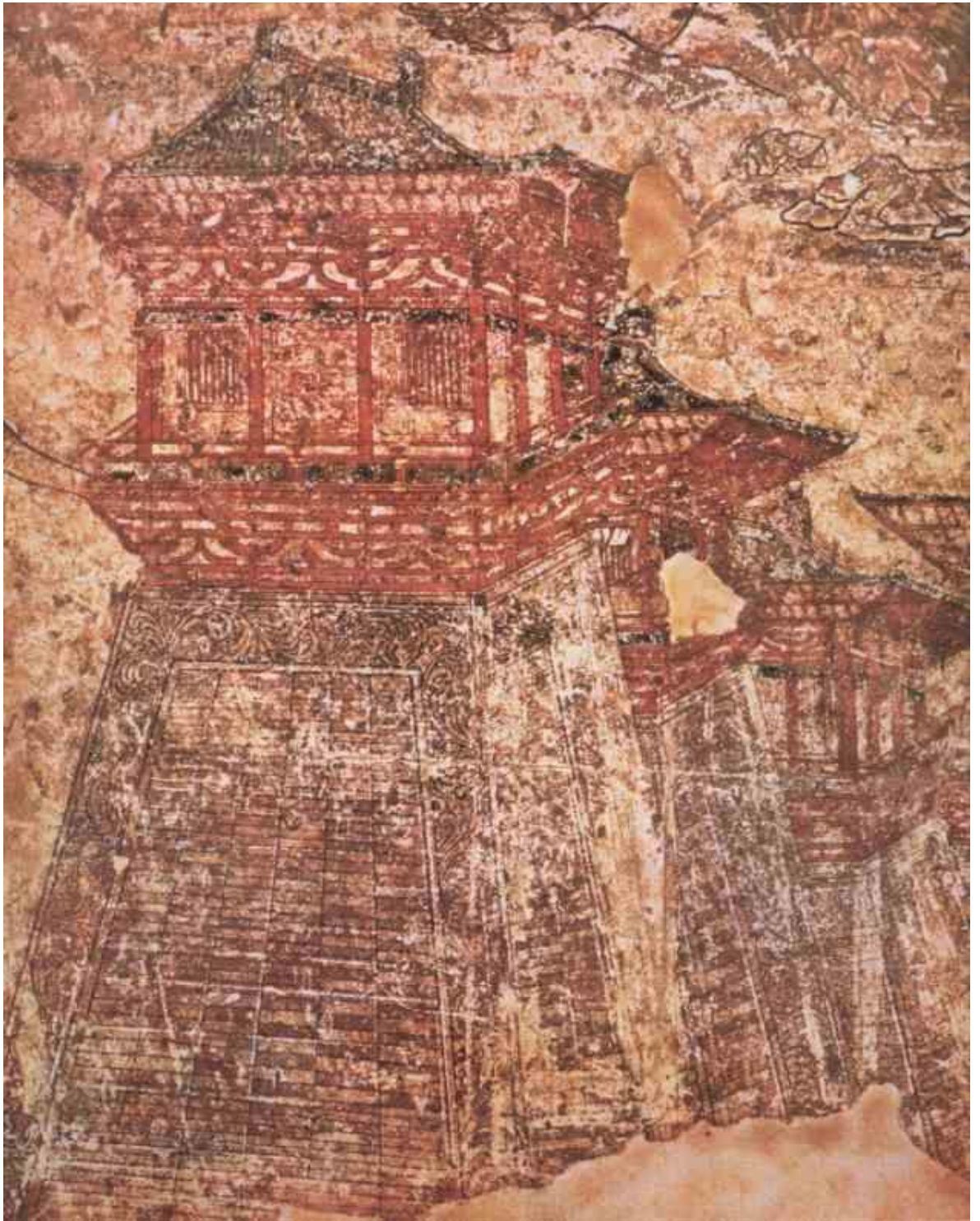


Figure 18
Qelou Tu,
mural painting (Tang),
the west wall of Yide prince's tomb, Xianyang, Shanxi province
(Image from *Wenwu*, 1998:3, 78)

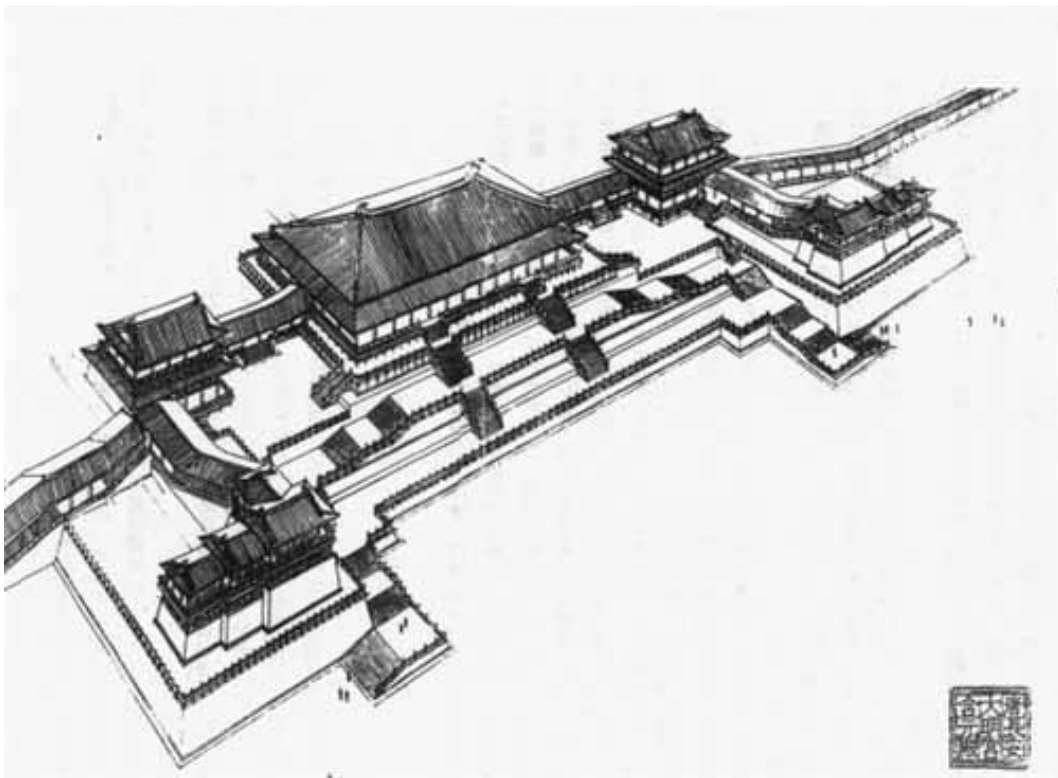


Figure 19
The reconstituted image of Hanyuan Palace (Tang)
(Image from *Gongdian kaogu tonglun*, 437)



Figure 20
Detail of *Western Pure Land Illustration*,
cave 217, Dunhuang, Gansu province
(Image from *Dunhuang Academy*)



Figure 21

A person drawing lines of architecture with ruler, brush and a bamboo chip
(Image from www.greatwuyi.com/mbrb/2008-11/14/content_323791.htm)



Figure 22

Attributed to the Huizong Emperor

Auspicious Cranes

Northern Song Dynasties, ink and colours on silk

51 x 138.2 cm

Liaoning Provincial Museum, Shenyang

(Image from www.lnmuseum.com.cn/huxing/show.asp?ID=6787)

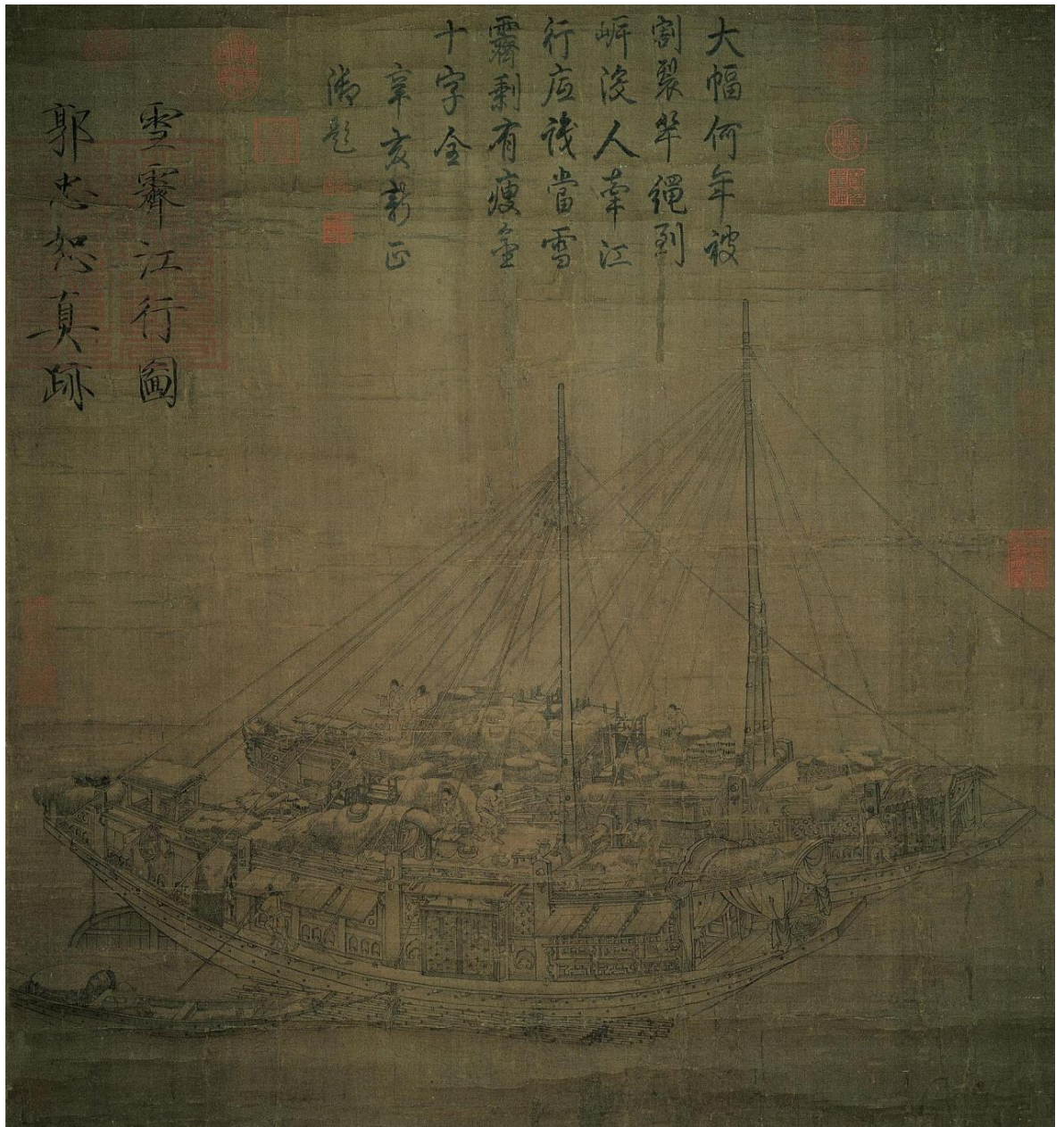


Figure 23
Guo Zhongshu
Travelling on a River After Snow
Northern Song, ink on silk
71.4 x 69.2 cm
National Palace Museum, Taipei
(Image from
painting.npm.gov.tw/getCollectionImage.aspx?ImageId=547321&r=76592045030)

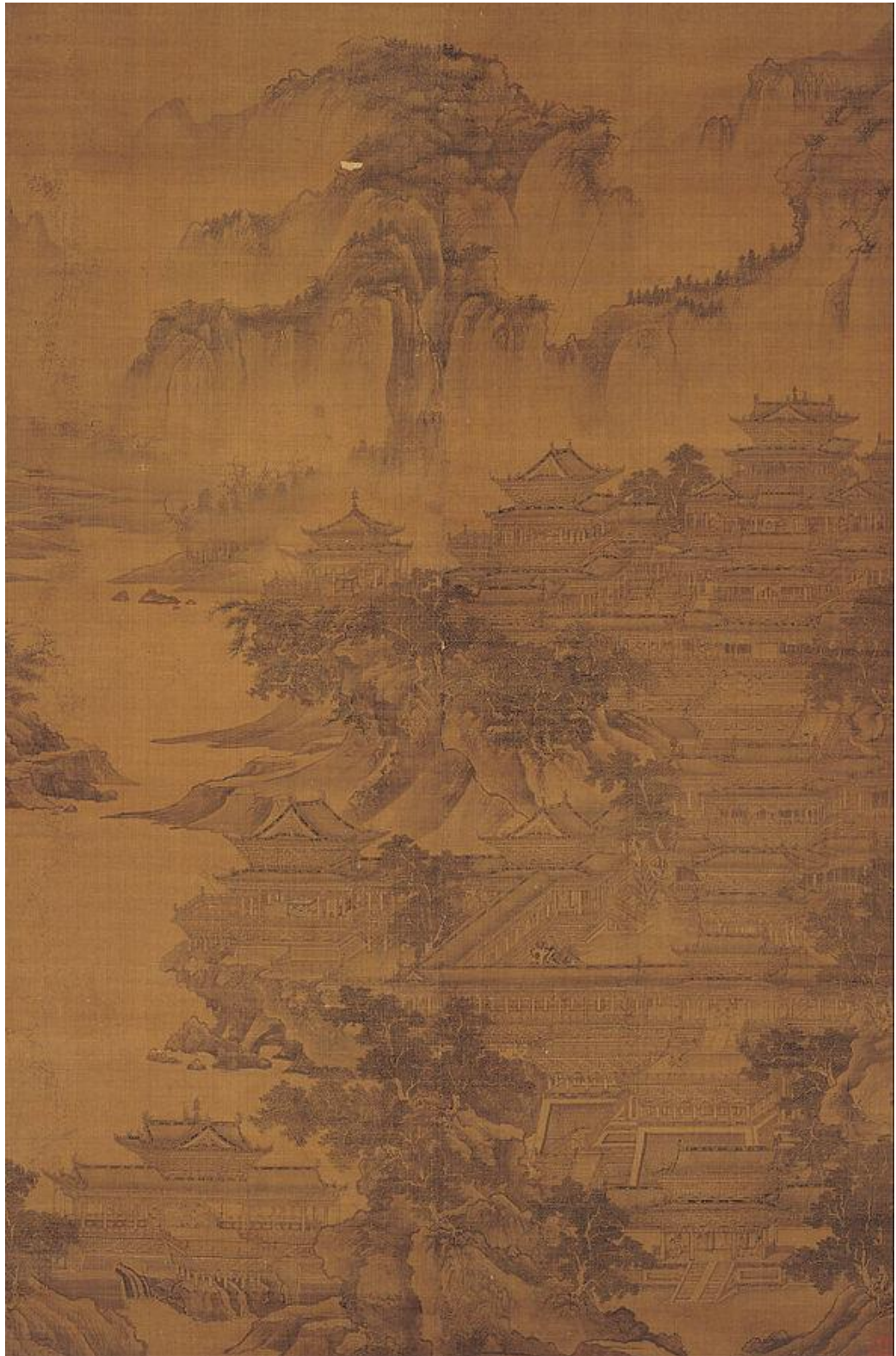


Figure 24

Attributed to Guo Zhongshu

Summer Palace of Emperor Ming Huang

ca. 12th to 14th century, ink on silk

105.6 x 161.5 cm

Osaka City Museum of Fine Arts, Osaka

(Image from artsandculture.google.com/asset/QgHf24a1IUW0rA)



Figure 25

Li Song

Watching the Tide on a Moonlight Night

Southern Song Dynasty, ink and colour on silk with gold

22.3 x 22 cm

National Palace Museum, Taipei

(Image from painting.npm.gov.tw/Painting_Page.aspx?dep=P&PaintingId=14533)

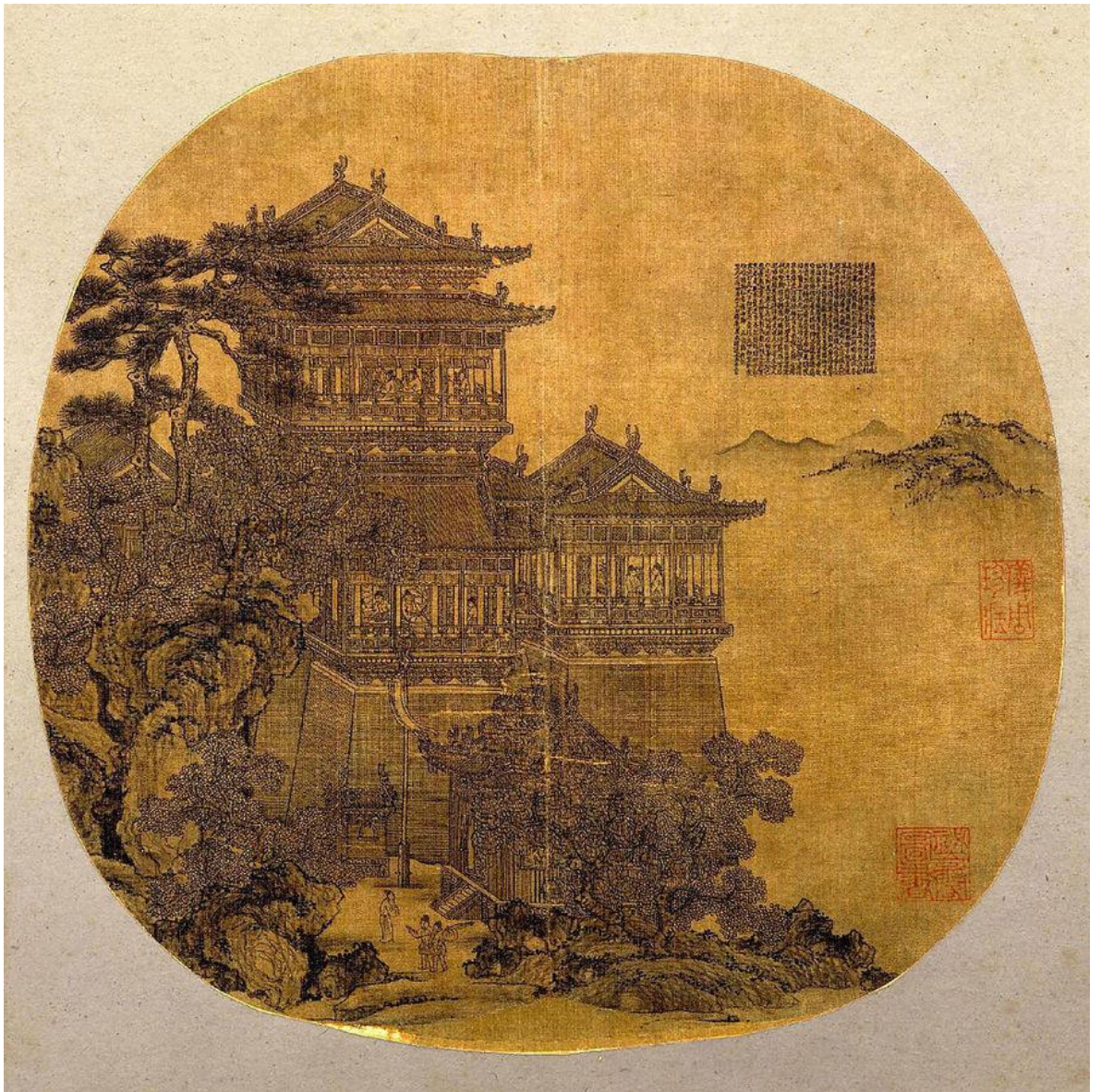


Figure 26

Xia Yong

Yueyang Tower

Yuan Dynasty, ink and colour on silk

25.2 x 25.8 cm

Palace Museum, Beijing

(Image from www.dpm.org.cn/collection/paint/234416.html)



Figure 27

Xia Yong

Yellow Crane Tower (1350), ink on silk, 20.6 x 26.7 cm

Metropolitan Museum of Art, New York

(Image from www.metmuseum.org/art/collection/search/41476)



Figure 28

Detail of *Watching the Tide on a Moonlight Night*, the bracket set

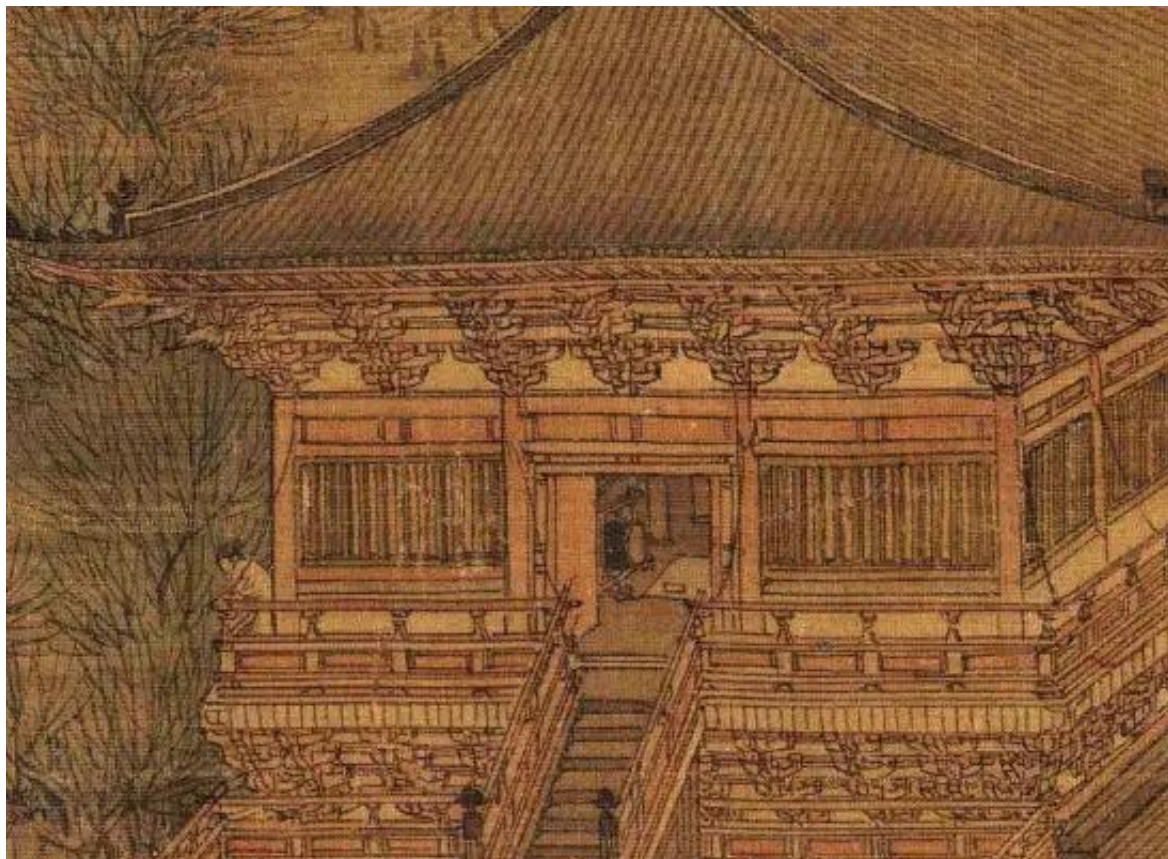


Figure 29
Detail of *Along the River During the Qingming Festival*, the bracket set



Figure 30
Attributed to Zhang Zeduan
Competition on the Jinming Pool
Northern Song (controversial), ink and colours on silk
28.5 x 28.6 cm
Tianjin Museum, Tianjin
(Image from *ZGMSQJ*, Painting Collection vol 4, 175)



Figure 31
Detail of Competition on the Jinming Pool



Figure 32
Wang Kui (1100–?)
Inner Palace, the west wall mural painting (1158–1167)
Yanshan Temple, Fanshi County, Shanxi province
(Image from *Yanshansi Jindai bihua*)

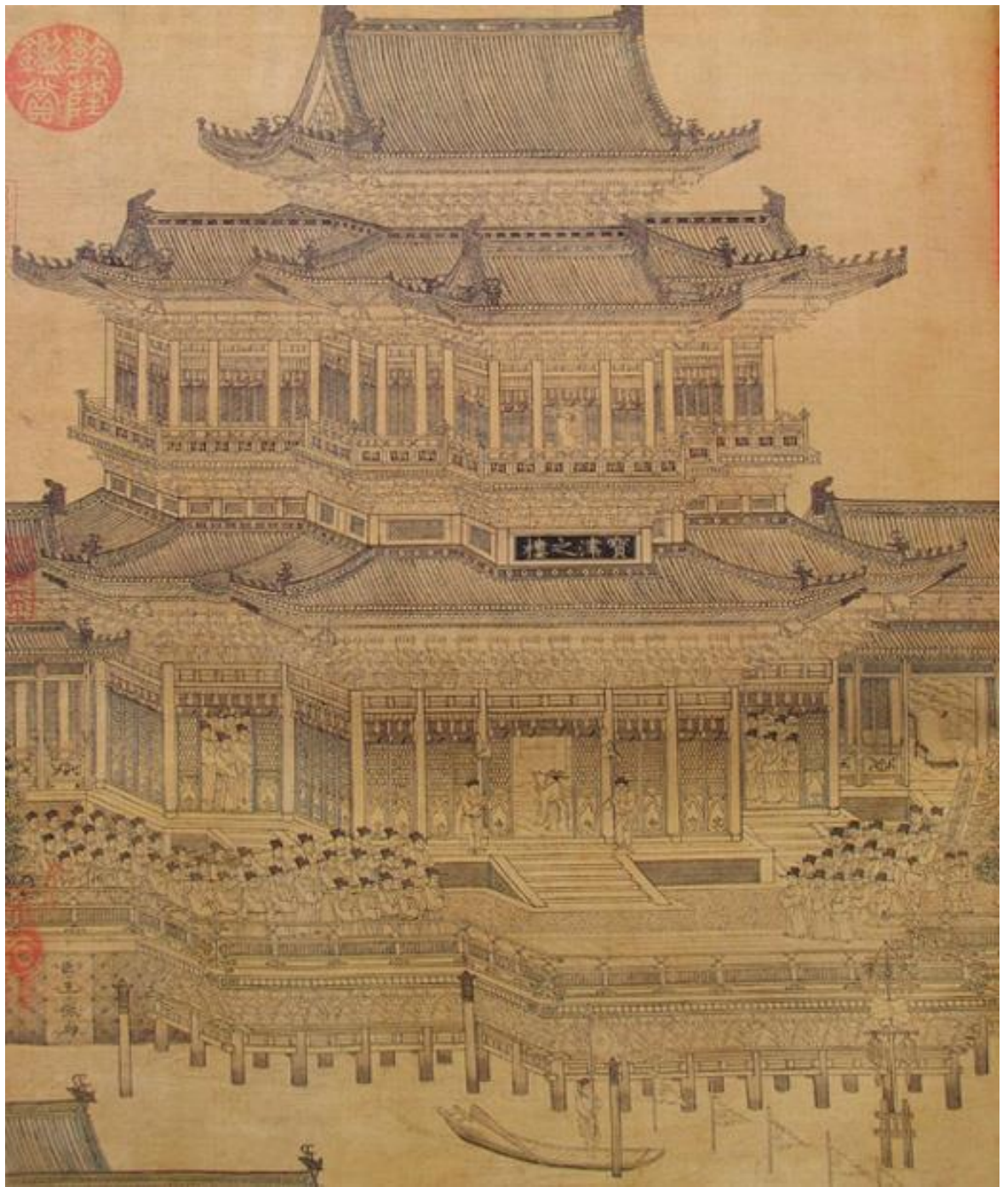


Figure 33
Wang Zhenpeng
Dragon Boat Regatta (part)
Yuan, *baimiao* (ink line drawing) on silk
30.2 x 243.8 cm
National Palace Museum, Taipei
(Image from painting.npm.gov.tw/Painting_Page.aspx?dep=P&PaintingId=767)



Figure 34

Chen Mu, Sun Hu, Jin Kun, Dai Hong, Cheng Zhidao

Along the River During the Qingming Festival

1736, ink and colours on silk

35.6 cm x 1152.8 cm

National Palace Museum, Taipei

(Image from painting.npm.gov.tw/Painting_Page.aspx?dep=P&PaintingId=3782)



Figure 35
Yuan Yao (?–1778)
Jiucheng Palace (1774)
ink and colours on silk, 189.7 x 230.7 cm
Palace Museum, Beijing
(Image from www.dpm.org.cn/collection/paint/229091.html)



Figure 36

Yuan Yao (?–1778)

Landscape of the Han River (1747)

ink and colours on silk, 165.2 x 262.8 cm

Palace Museum, Beijing

(Image from www.dpm.org.cn/collection/paint/228208.html)

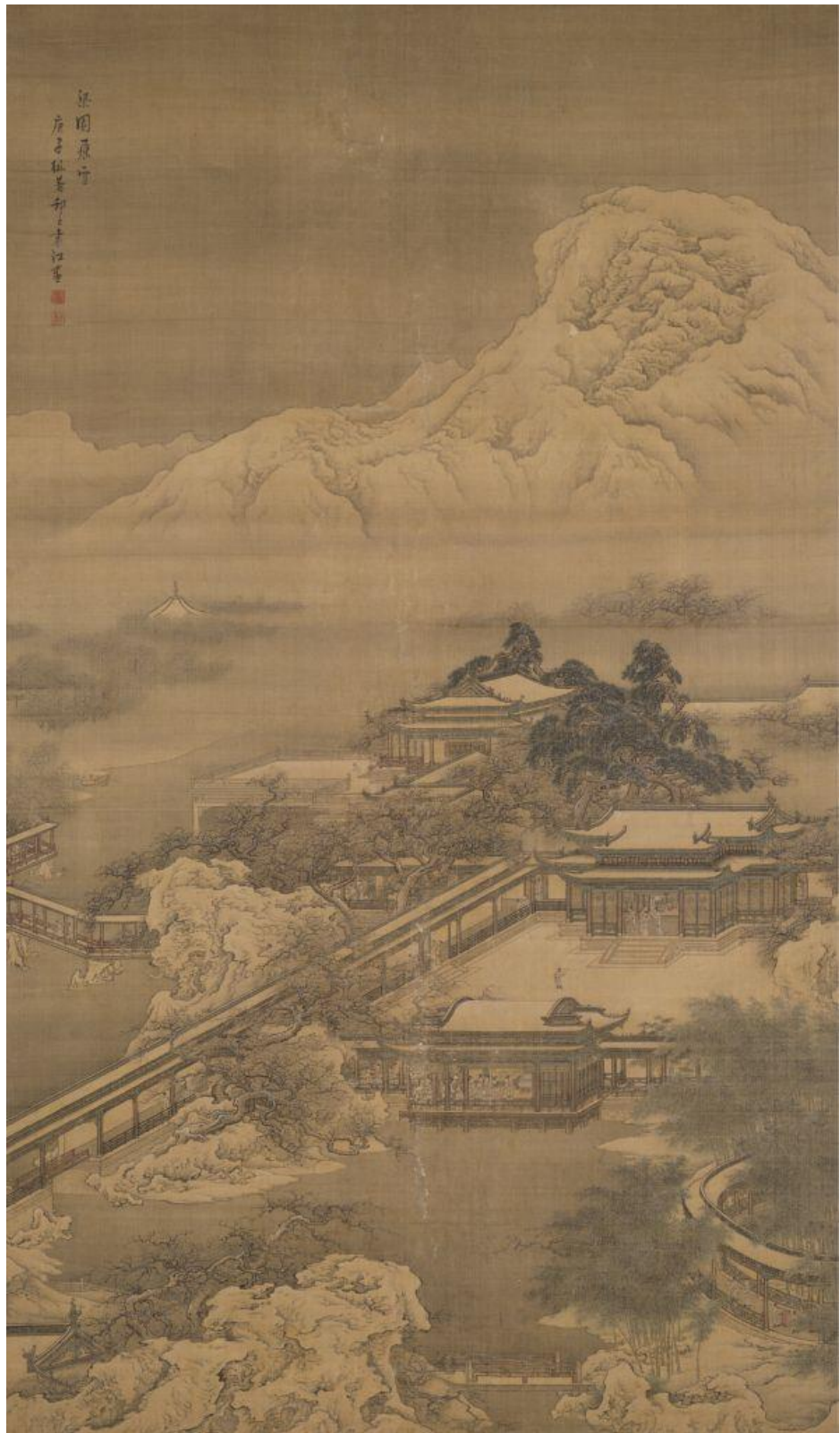


Figure 37
Yuan Jiang (1662–1735)
Snow Scene of Liangyuan (1720)
ink and colours on silk, 202.8 x 118.5 cm
Palace Museum, Beijing
(Image from www.dpm.org.cn/collection/paint/228772.html)

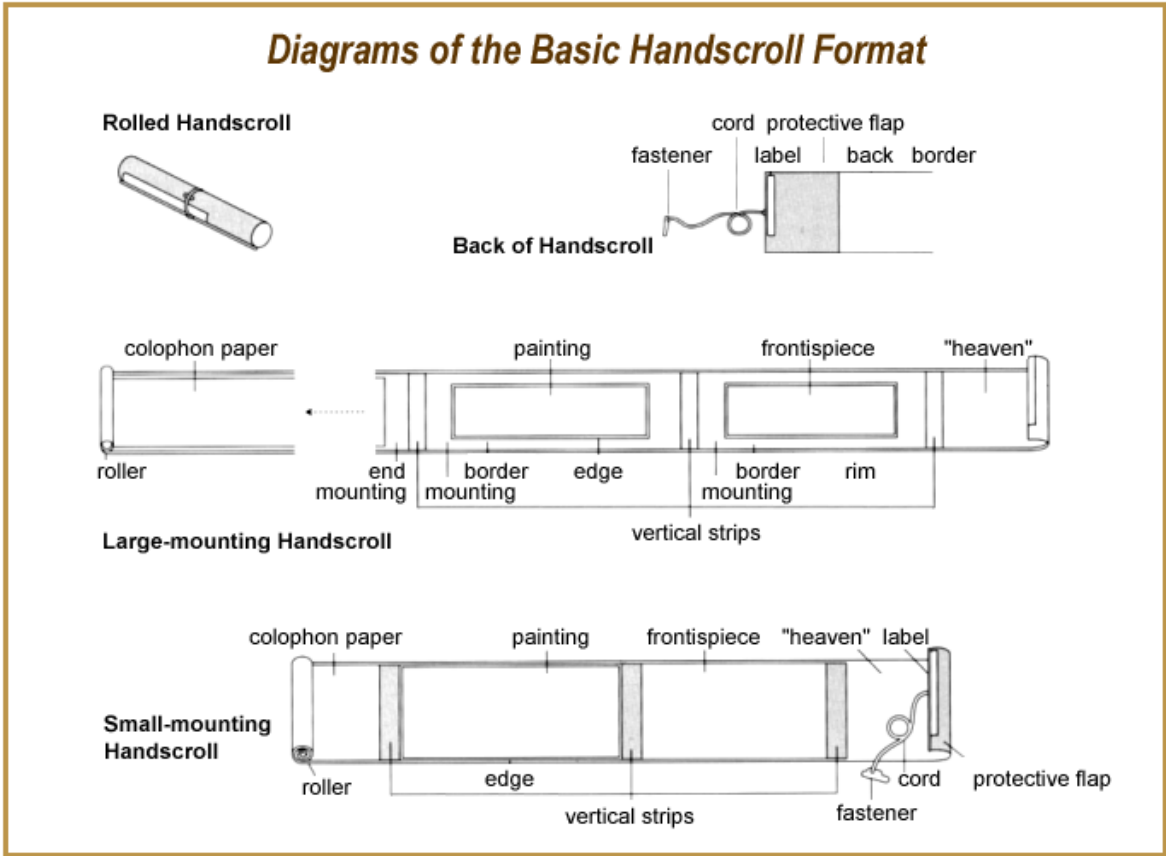


Figure 38
Diagrams of the basic handscroll format
(Image from www.npm.gov.tw/english/exhibition/ehan0101/ehan0101.htm)

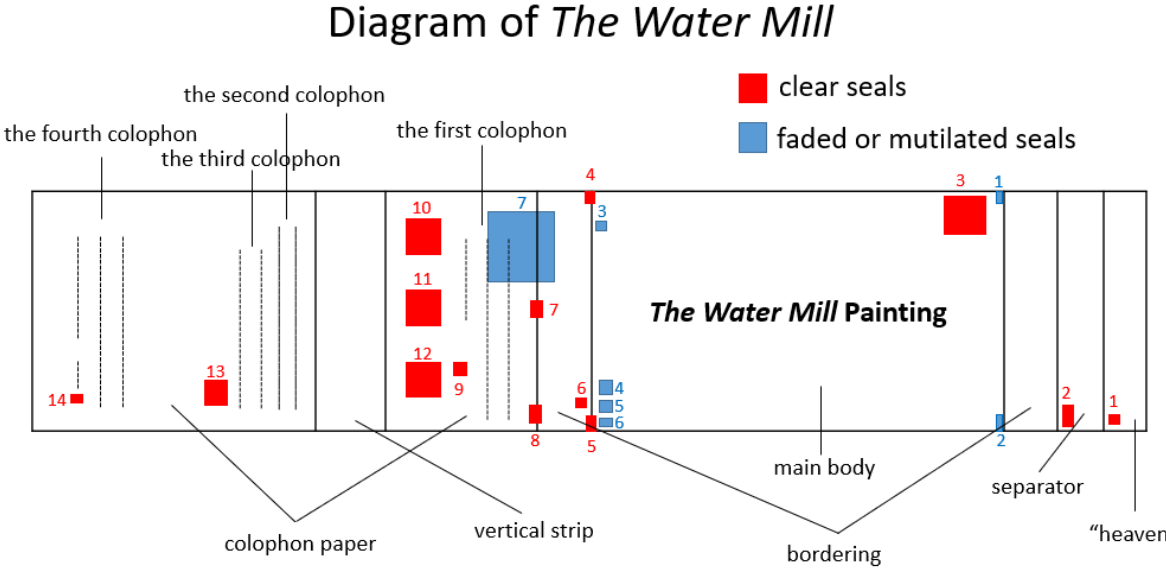


Figure 39
Diagram of *The Water Mill* format

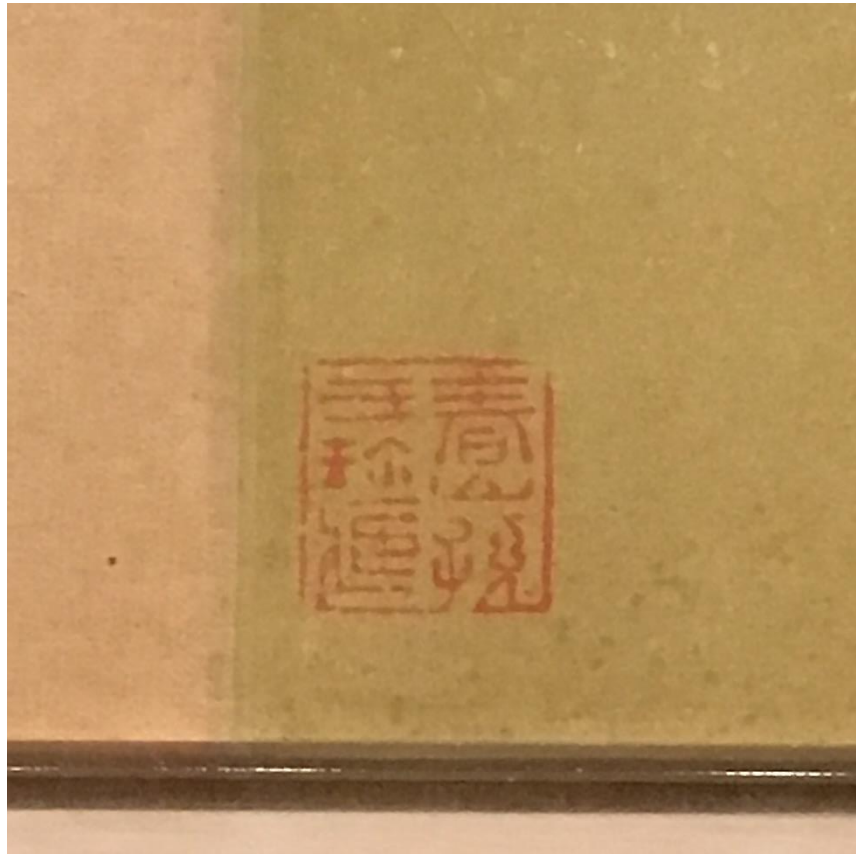


Figure 40
 Detail of *The Water Mill*, the seal “春山孫氏珍藏”
 (The Treasured Collection of the Spring Mountain of the Sun Family)



Figure 41
 The Seal “春山孫氏珍藏”
 (The Treasured Collection of the Spring Mountain of the Sun Family)
 in a privately owned book *Pushuting ji* 曝書亭集



Figure 42
Gong Xian (1618–1689)
Watching Mountains
ink on paper, 146 x 57 cm
pre-owned by Alice Boney (1901–1988)
(Image from auction.artron.net/paimai-art0038181565)

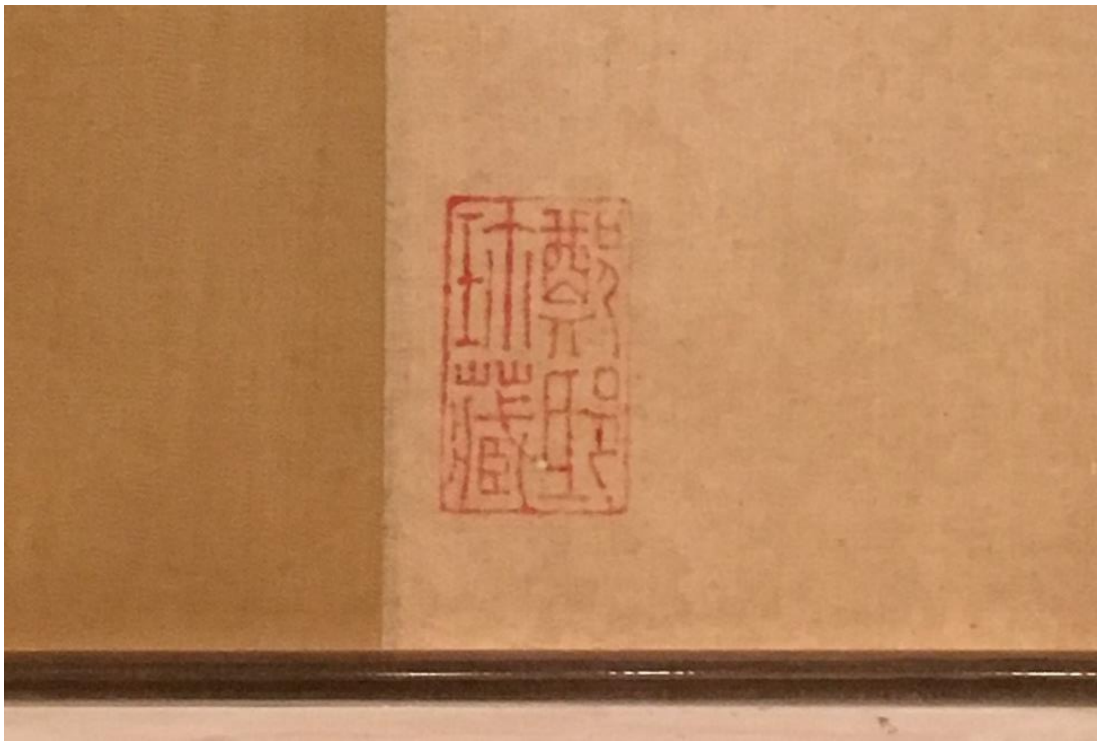


Figure 43
Detail of *The Water Mill*, the seal “鄭邸珍藏”
(The Treasured Collection by The Zheng House)



Figure 44
Detail Detail of *The Water Mill*, the seal “天曆之寶”
(same as the Figure 4)



Figure 45
Detail of *Early Snow on the River*, the seal “天曆之寶”
Zhao Gan
Southern Tang (Five Dynasties), ink and colours on silk
25.9 x 376.5 cm
National Palace Museum, Taipei
(Image from painting.npm.gov.tw/Painting_Page.aspx?dep=P&PaintingId=51)



Figure 46
Attributed to the Huizong Emperor
The Five-coloured Parakeet, Northern Song
ink and colours on silk, 53.3 x 125.1 cm,
Museum of Fine Arts, Boston
(Image from collections.mfa.org/objects/29081?image=6)

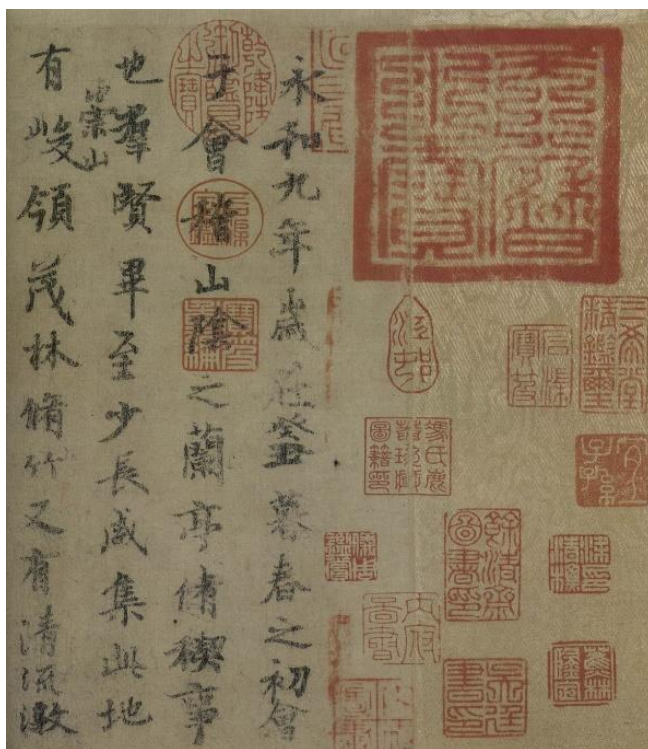


Figure 47

Attributed to Yu Shinan (558–638)

Lantingji Xu

Tang, ink on paper, 24.8 x 57.7 cm

Palace Museum

(Image from www.dpm.org.cn/collection/impres/228279.html)



Figure 48

The seal “蕉林”

(The private seal of Liang Qingbiao)

(Image from *Seals of Chinese painters and collectors of the Ming and Ch'ing periods, 573–574*)

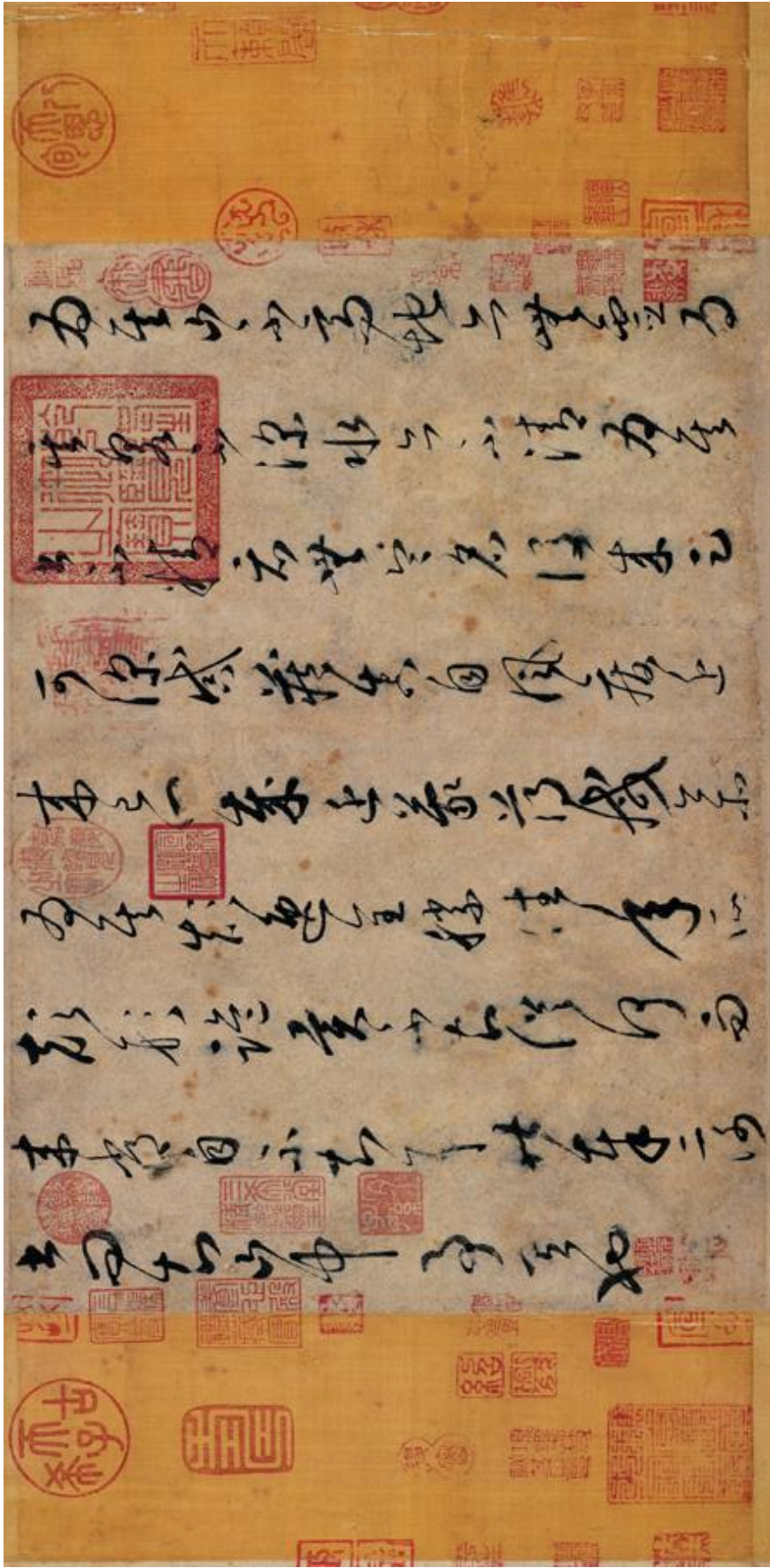


Figure 49

Huai Su (725–785)

The Comments on Calligraphy

Tang, ink on paper, 38.5 x 40.5 cm

Liaoning provincial Museum, Shenyang

(Image from www.lnmuseum.com.cn/huxing/show.asp?id=7101)



Figure 50

The Xuanzong Emperor (685–762)

The Ode on Pied Wagtails (ca.716–732)

Tang, ink on paper, 24.5 x 184.9 cm

National Palace Museum, Taipei

(Image from painting.npm.gov.tw/Painting_Page.aspx?dep=P&PaintingId=14715)



Figure 51
Liang Shimin
The Isles in Snow
Northern Song, ink and colours on silk, 26.5 x 145.6 cm
Palace Museum, Beijing
(Image from www.dpm.org.cn/collection/paint/231254.html)

印名式	御书葫芦印	双龙圆玺	宣和连玺	政和长玺	宣和长玺	政和连玺	内府图书之印
I式							
II式							

Figure 52

The *Xuanhe* seals in the *Xuanhe* format for calligraphy
 (Image from *Palace Museum Journal*, 2005:1, 55)

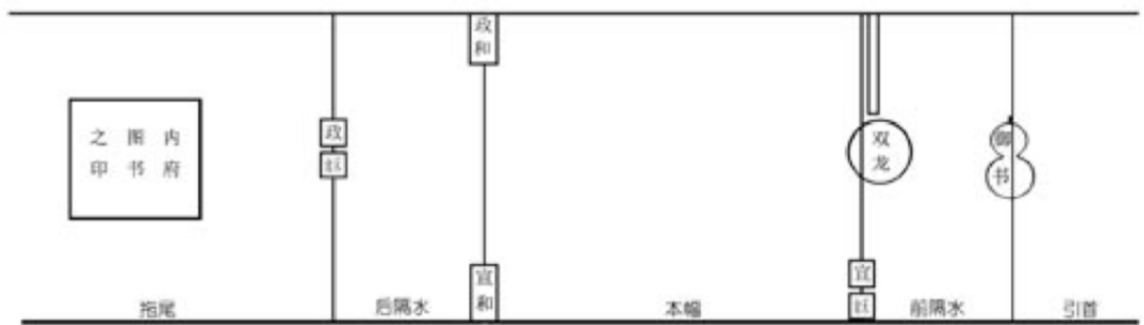


Figure 53

The diagram of the *Xuanhe* format for calligraphy
 (Image from *Palace Museum Journal*, 2005:1, 71)



Figure 54
The “heaven” section of *The Water Mill*
(Photo by BR)



Figure 55
Detail of *The Water Mill*, half of a *Zhenghe* rectangular seal
at the top seam between the latter bordering and the painting
(Photo from *ZGHHMP*, vol 21)

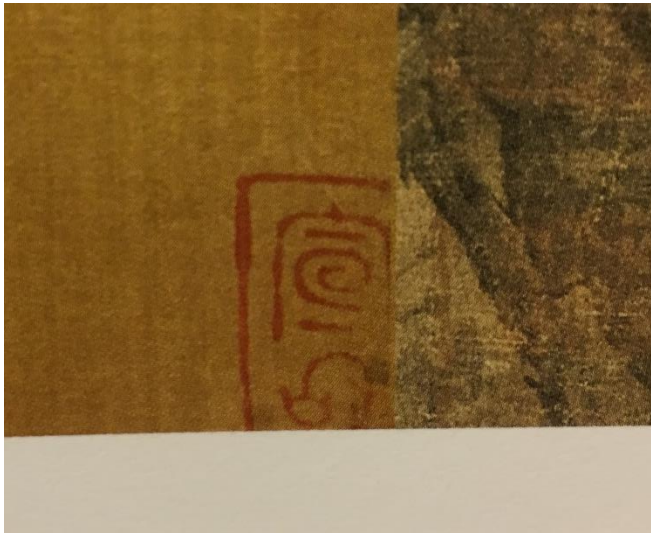


Figure 56

Detail of *The Water Mill*, more than half of a *Xuanhe* rectangular seal at the bottom seam between the latter bordering and the painting (Photo from ZGHHMP, vol 21)



Figure 57

Detail of *The Water Mill*, a *Zhenghe* seal which were constituted of two small seals at the middle seam between the latter bordering and the colophon paper (Photo from ZGHHMP, vol 21)

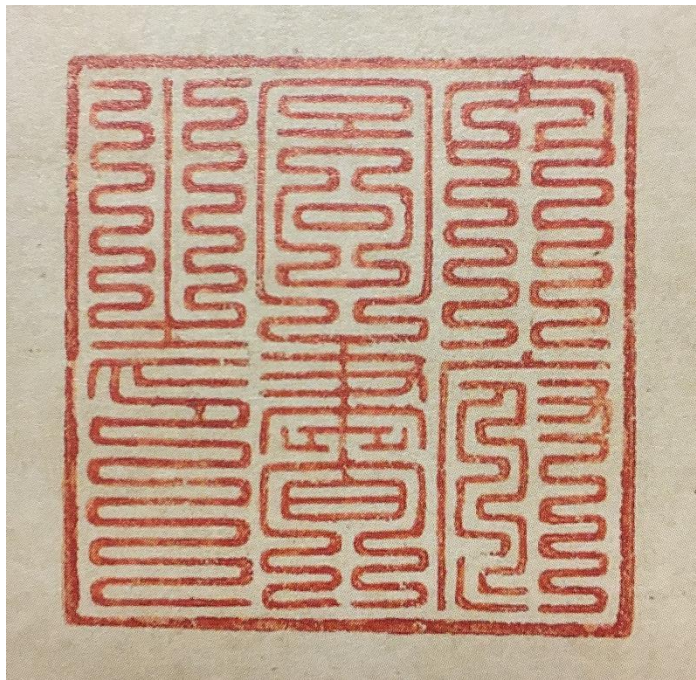


Figure 58

Detail of *The Water Mill*, the *Neifu tushu zhiyin* quadrate seal
at the middle of the colophon paper
(Photo from *ZGHHMP*, vol 21)

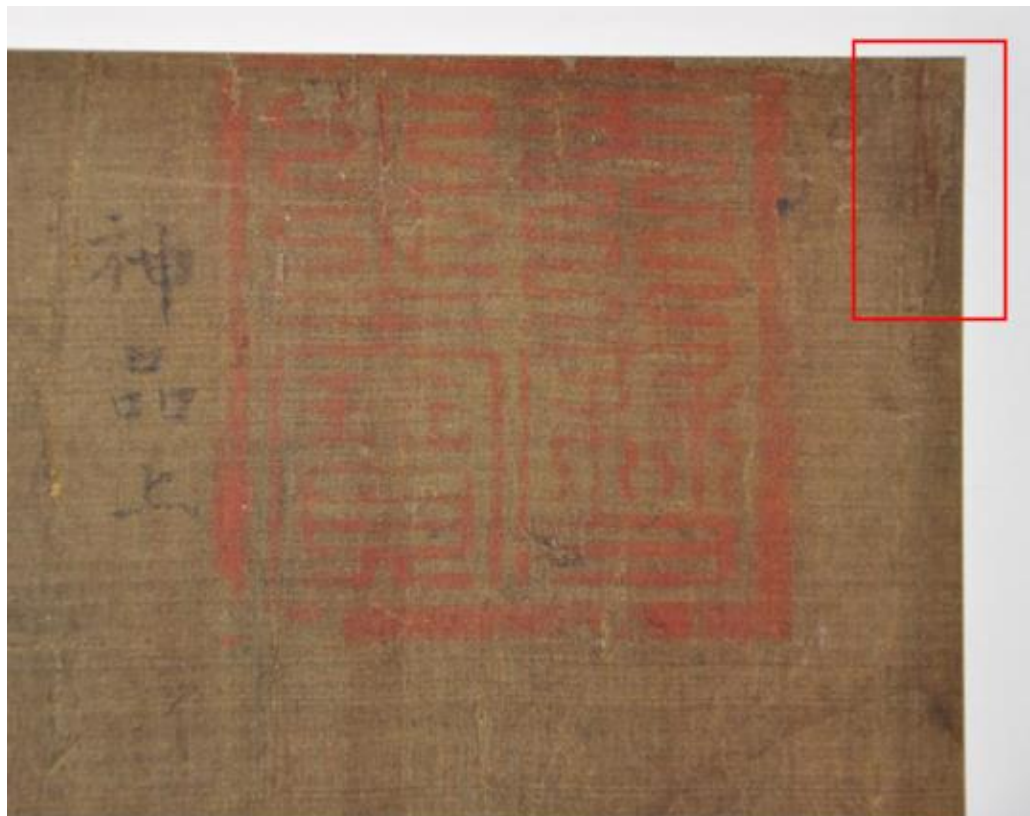


Figure 59

Detail of *The Water Mill*, the faded seal
at the top seam between the former bordering and the painting
(Photo from *ZGHHMP*, vol 21)



Figure 60
Detail of *The Water Mill*, the faded seal
at the bottom seam between the former bordering and the painting
(Photo from ZGHHMP, vol 21)



Figure 61
Detail of *The Water Mill*, the seal “雲煙過眼”
(Photo from ZGHHMP, vol 21)



Figure 62
Huaya of the Huizong Emperor
(Image from *ZGMSQJ*, Painting Collection vol 3, 84)

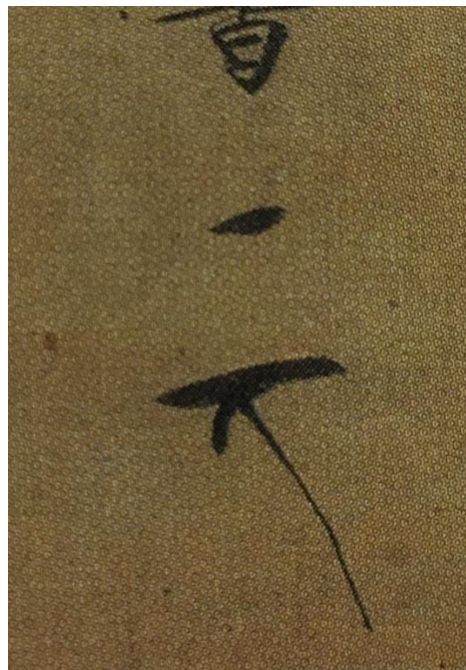


Figure 63
Huaya of the Huizong Emperor
(Image from *ZGMSQJ*, Painting Collection vol 3, 86)

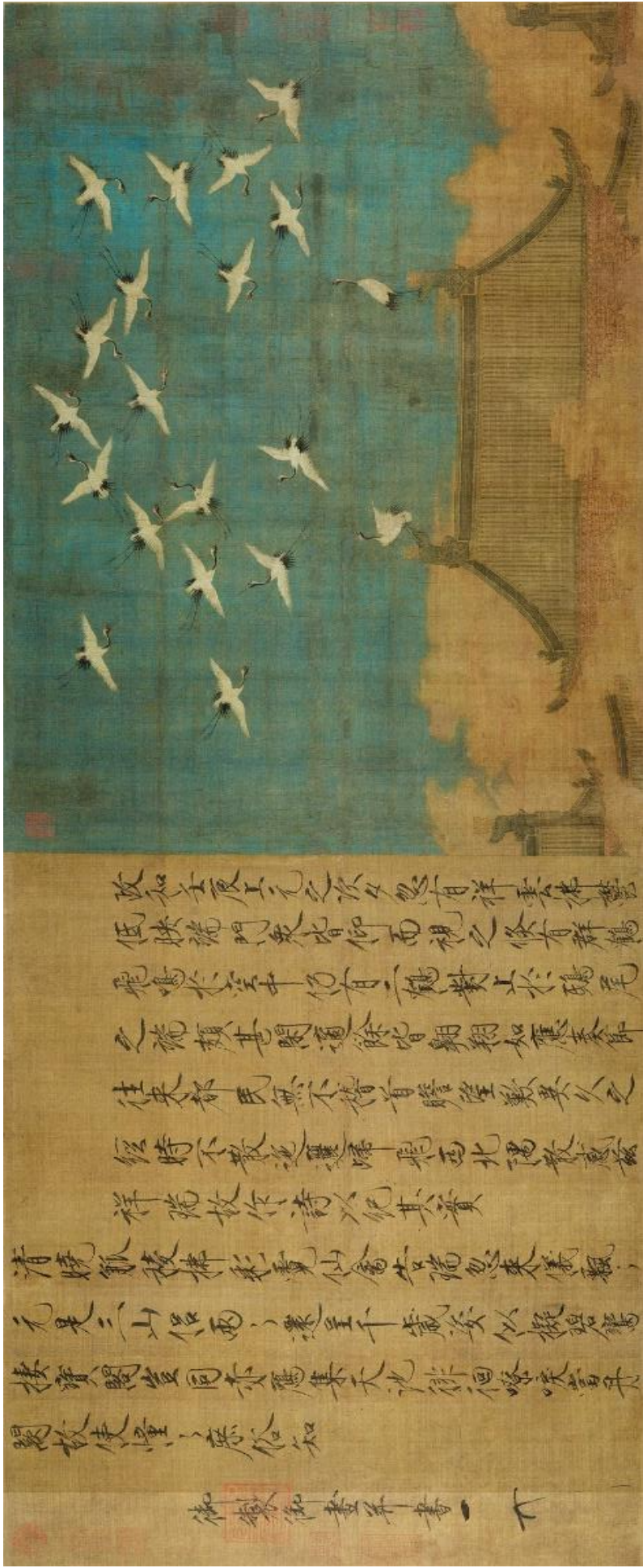


Figure 64

Huaya of the Huizong Emperor

(Image from www.sohu.com/a/168764877_99891639)



Figure 65
 Detail of *Tianshui's Copy of Zhang Xuan's "Pounding Silk"*
 Attributed to the Huizong Emperor
 Northern Song, ink and colours on silk, 37 x 145.3 cm
 Museum of Fine Arts, Boston
 (Image from collections.mfa.org/objects/28127)



Figure 66
 Detail of *Tianshui's Copy of Zhang Xuan's "Spring Outing of the Court Ladies"*
 Attributed to the Huizong Emperor
 Northern Song, ink and colours on silk, 51.8 x 148 cm
 Liaoning Provincial Museum, Shenyang
 (Image from www.lnmuseum.com.cn/huxing/show.asp?ID=7105)



Figure 67
Detail of *The Water Mill*, the seal “雛鳳樓”



Figure 68
Detail of *The Water Mill*, the seal “王守仁印”

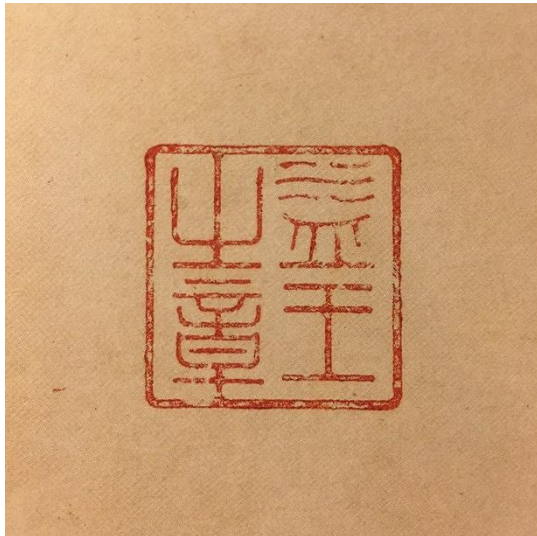


Figure 69
Detail of *The Water Mill*, the seal “益王之章”



Figure 70
The seal “益王之章”
in a reprinted stone rubbing painting *Lanting Tu* (Wanli period of the Ming)
(Image from auction.artron.net/paimai-art0071212320/)



Figure 71
Detail of *The Water Mill*, the seal “晉府圖書”
(Photo from *ZGHHMP*, vol 21)



Figure 72
Detail of *The Water Mill*, the seal “磐石父”
(Photo from ZGHHMP, vol 21)

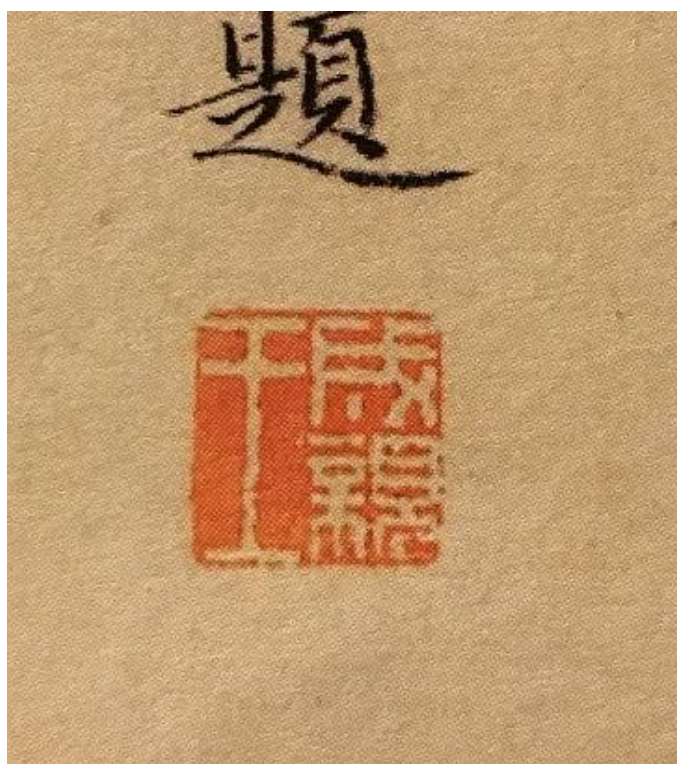


Figure 73
Detail of *The Water Mill*, the seal “成親王”
(Photo from ZGHHMP, vol 21)

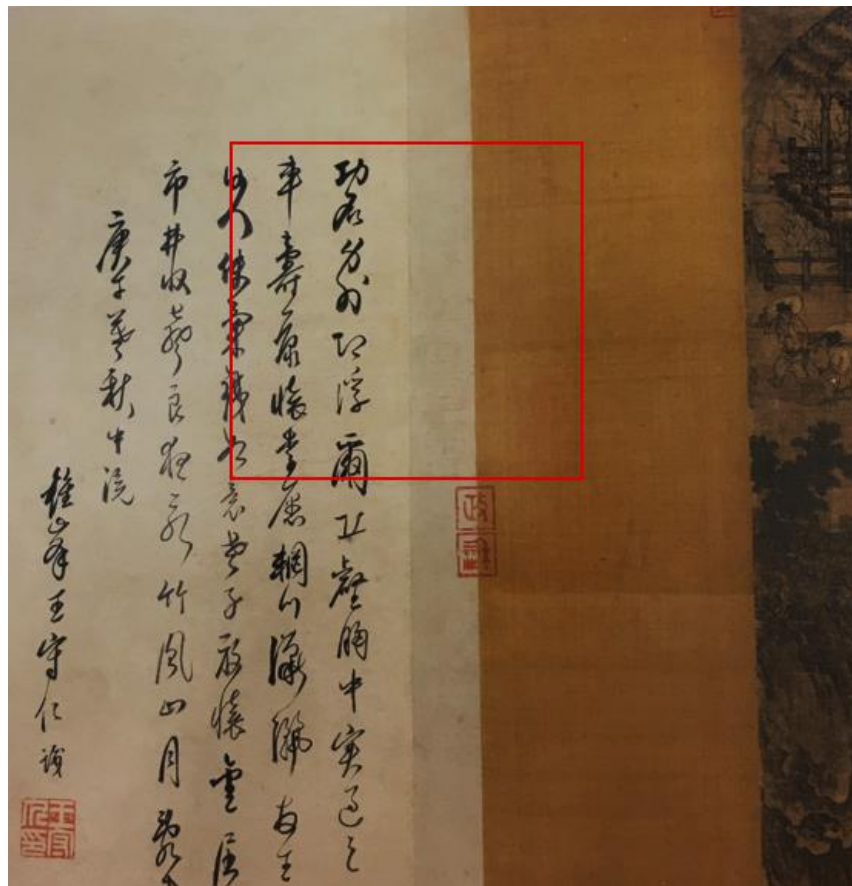


Figure 74

Detail of *The Water Mill*, a large light quadrate seal



宋 直州管下霸廩都黎县令

Figure 75

An official seal of a county magistrate, Southern Song
(Image from *The History and Art of Chinese Seals*, 227)



金.兴中统管都元帅府印

Figure 76

A seal of a commander, Jin

(Image from *The History and Art of Chinese Seals*, 232)



元.益都陪管军千户建字号之印

Figure 77

A seal of an official, Yuan

“Seal of Jian Zi Hao Branch of Chief Officer in Charge of a Thousand Households of Yidu Street”

(Image from *The History and Art of Chinese Seals*, 240)



Figure 78

大帥國王都行省之印
 (印背部銘文正楷陰刻：大帥國王都行省之印、大定元年、禮部造。)
 元代太師國王木華黎九疊篆印

A seal of a commander, Yuan
 (the size that a normal seal of a commander of the Yuan Dynasty
 and a hand of an adult male)



Figure 79

管領本投下中興等路民匠達魯花赤印
 A seal of a craftsman, Yuan, 8.2 x 8.1 cm
 “Seal of the Chief Officer in Charge of Folk Craftsman in Zhongxing Road, etc”
 (Image from *The History and Art of Chinese Seals*, 246)

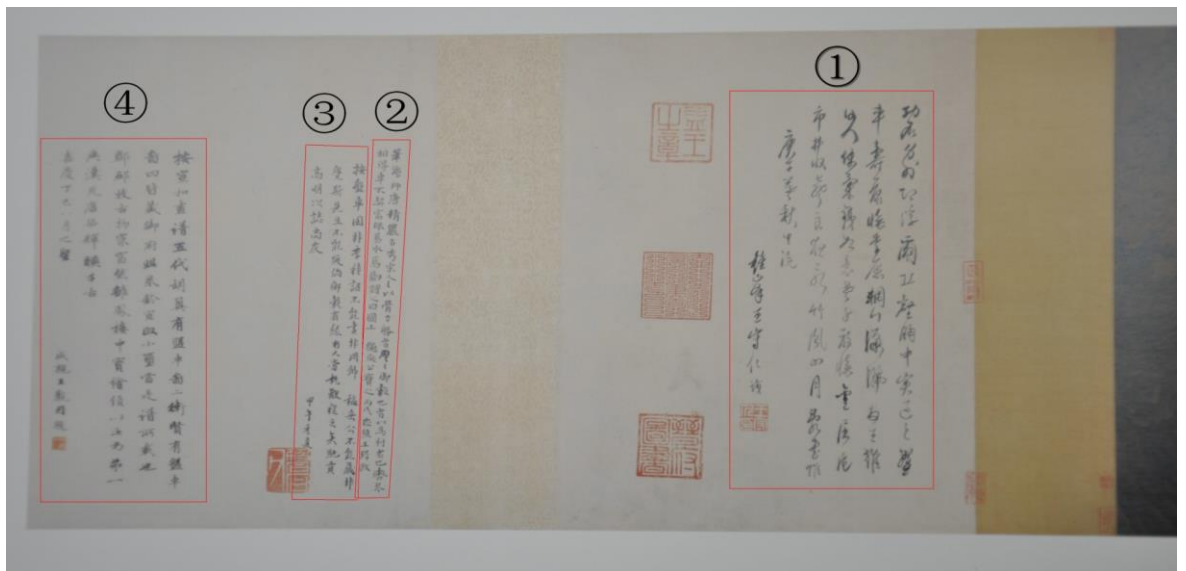


Figure 80
Colophons on *The Water Mill*
(Photo from ZGHHMP, vol 21)



Figure 81
The map which shows the locations of Beijing, Taiyuan and Luling
(Image from the Google Map)

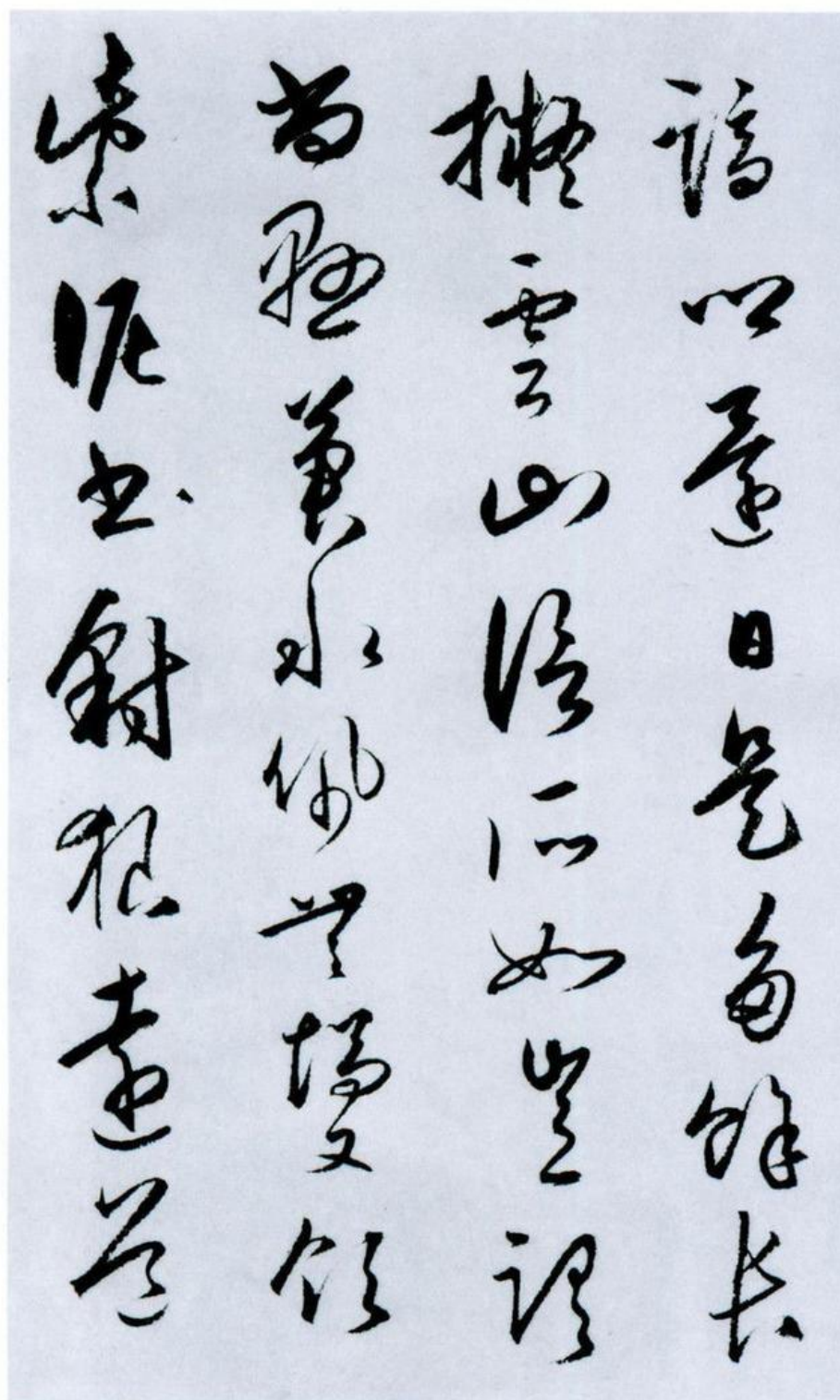


Figure 82

Wang Shouren (1472–1529)

Longjiang liubie shi (part, ca.1516)

28.1 x 296.6 cm, ink on paper

Palace Museum, Beijing

(Image from www.360doc.com/content/14/0908/23/15883912_408034869.shtml)



昔者聖王將建國必先慎乎農夫農者天下之本也... (Text continues in vertical columns, discussing the importance of agriculture and the role of oxen in society.)

耕者天下之本也... (Text continues in vertical columns, further elaborating on the agricultural theme and the artist's perspective.)

Figure 83

Han Huang (723–787)

The Five Bulls

Tang, ink and colours on paper

20.8 x 139.8 cm

Palace Museum, Beijing

(Image from www.dpm.org.cn/collection/paint/234599.html)

丙戌春過北海齋觀米海嶽天馬賦矯沉雄變化于獻之柳虞自
 為伸縮觀之不忍去噫兵燹之餘一時文獻凋剝乃董存此卷光怪陸
 離不滅沒於瓦礫物之遭錄寔遇亨可勝歎耶北海孫公稚嗜古博
 通海岳何不幸嘉書經戎行何幸出之家預倭翰登君子之堂逢北海
 為與代知已也天下事盛衰顯晦豈不有數存虜其間乎哉予不意今年
 復見北海又復觀海岳及該家字畫疇謂予顛沛後非幸歟 孟津鐸

Figure 84

The inscription (ca.1646) of Wang Duo (1592–1652) on Postscript on Semi-Cursive Handwriting Tianma Fu of Mi Fu



Figure 85
A fragmentary signature on *The Water Mill*
(Photo from ZGHHMP, vol 21)



Figure 86
Detail of *The Water Mill*, the poster “新酒”



Figure 87
Detail of *Along the River During the Qingming Festival*, the words “新酒”



Figure 88
Detail of *The Water Mill*, willows



Figure 89
Detail of *The Water Mill*, reeds



Figure 90

Detail of *Along the River During the Qingming Festival*, willows



Figure 91

Detail of *Along the River During the Qingming Festival*, willows and the leafless trees



Figure 92
leaves of a pagoda tree
Beihai Park, Beijing
(Photo by BR)



Figure 93
The alternate and pinnate-leaved trees in *The Water Mill*



Figure 94

Detail of *The Water Mill*, the alternate and pinnate leaves

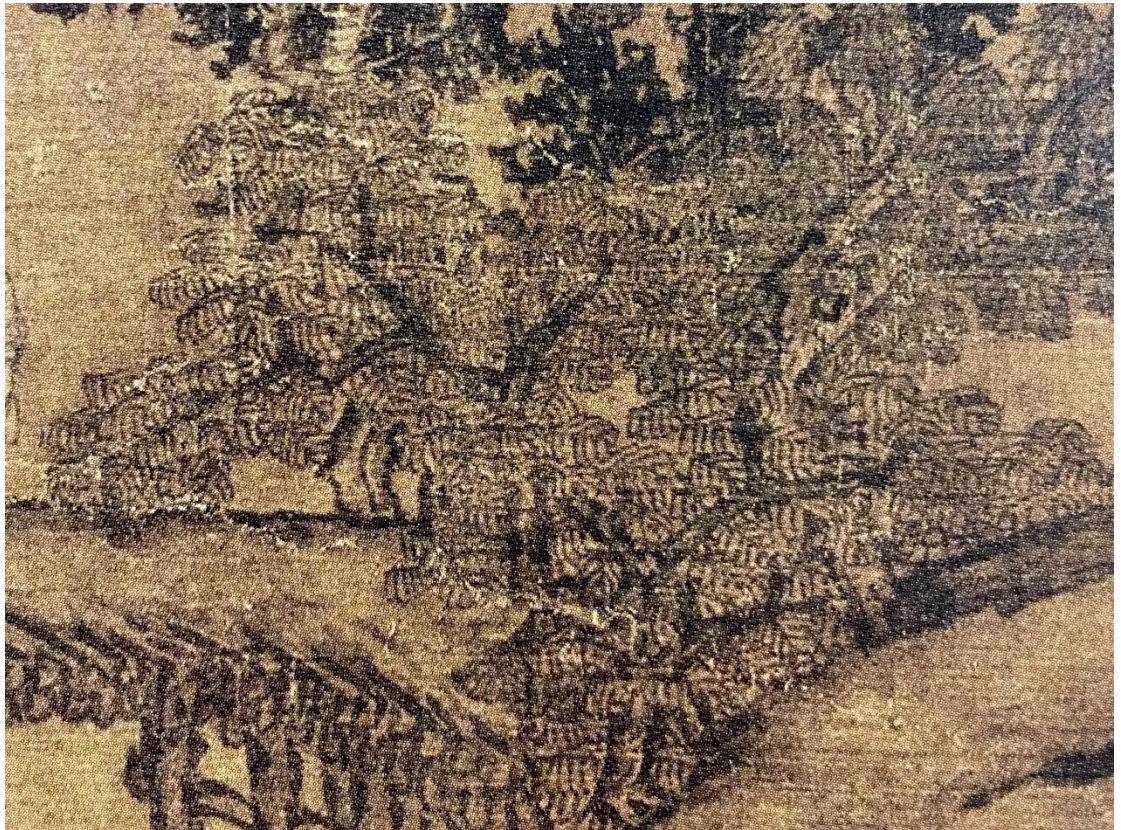


Figure 95

Detail of *The Water Mill*, the yellow plant with the alternate and pinnate leaves



Figure 96
leaves of an elm tree
(Image comes from www.huabaike.com)



Figure 97
Detail of *The Water Mill*, the tree at the right terrace

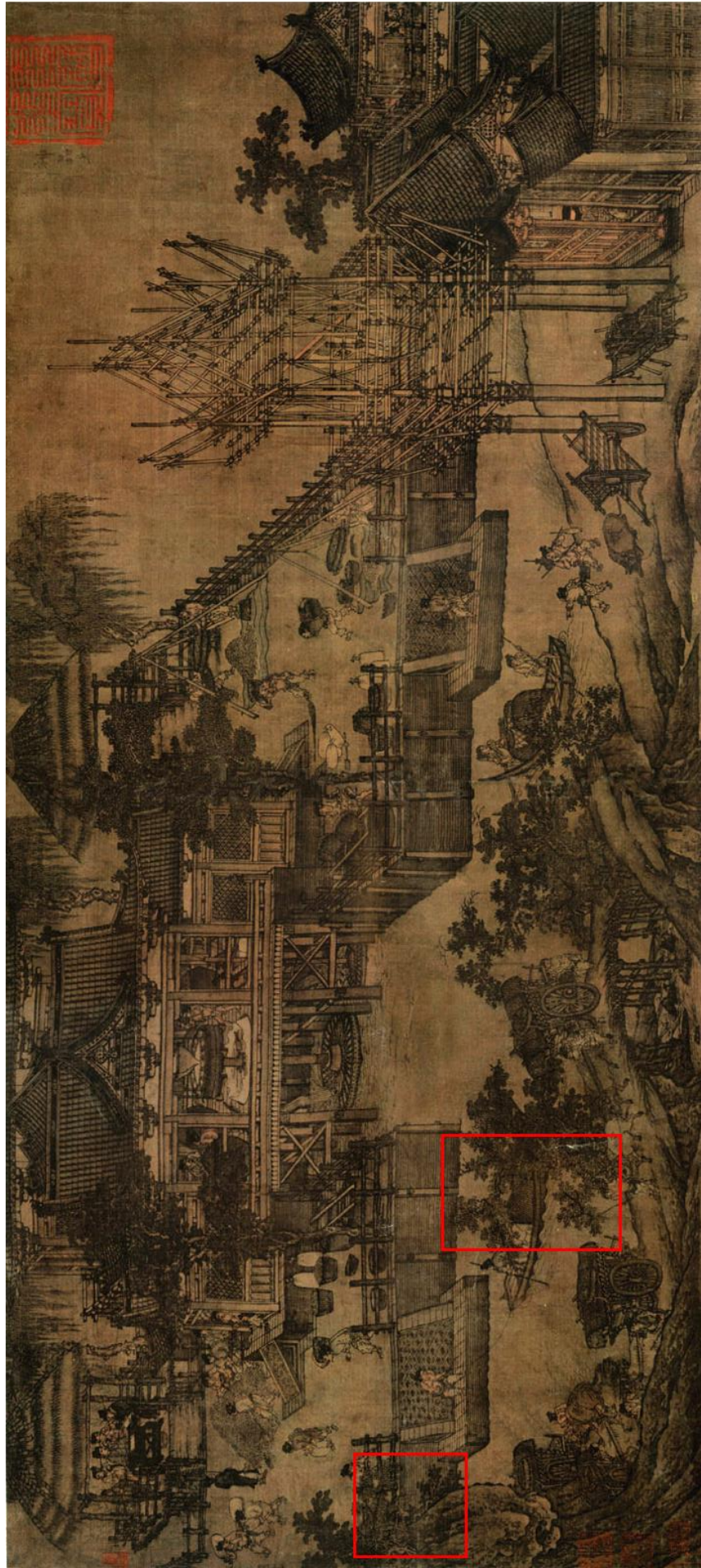


Figure 98
The round-leaved trees in *The Water Mill*

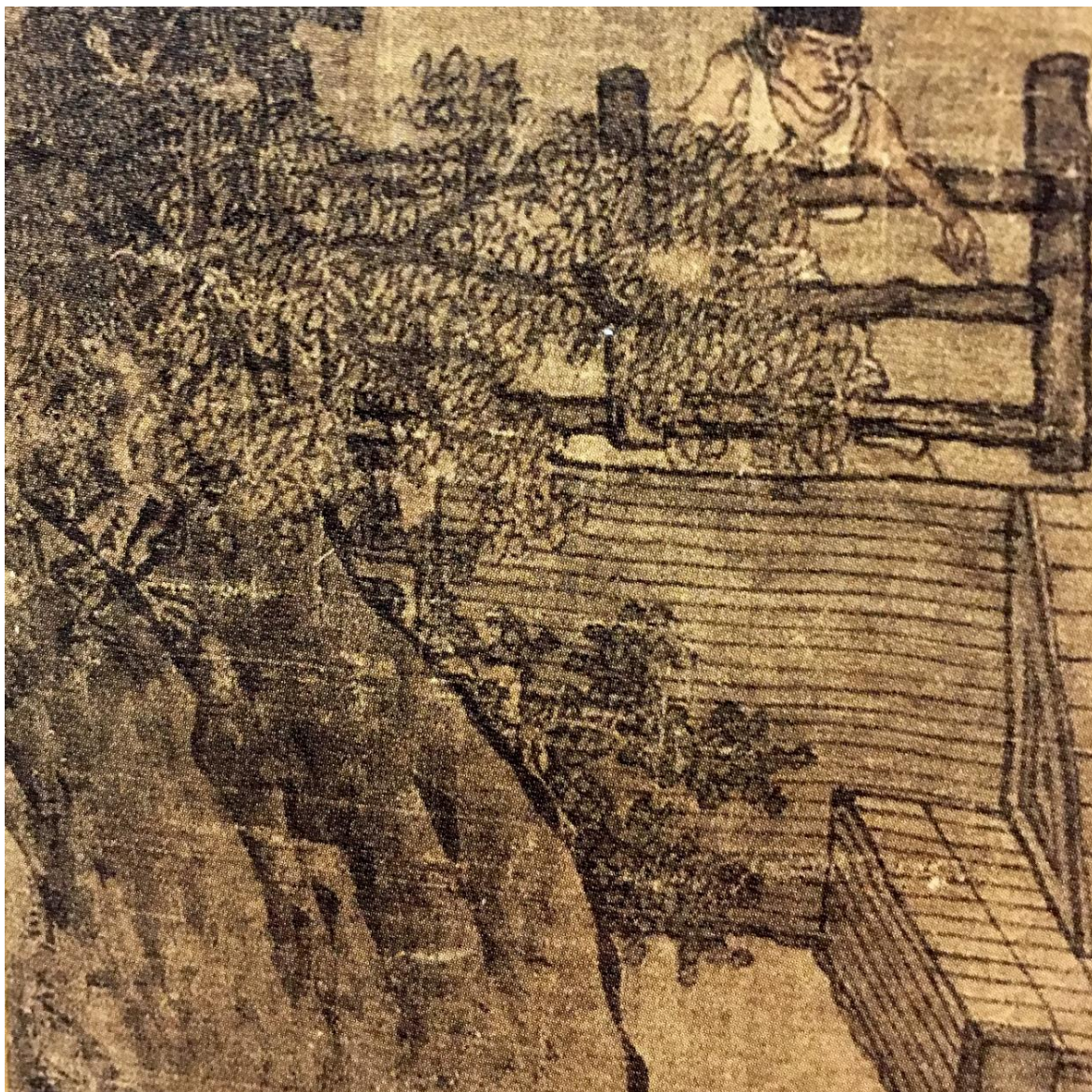


Figure 99

Detail of *The Water Mill*, the round leaves in blue and yellow

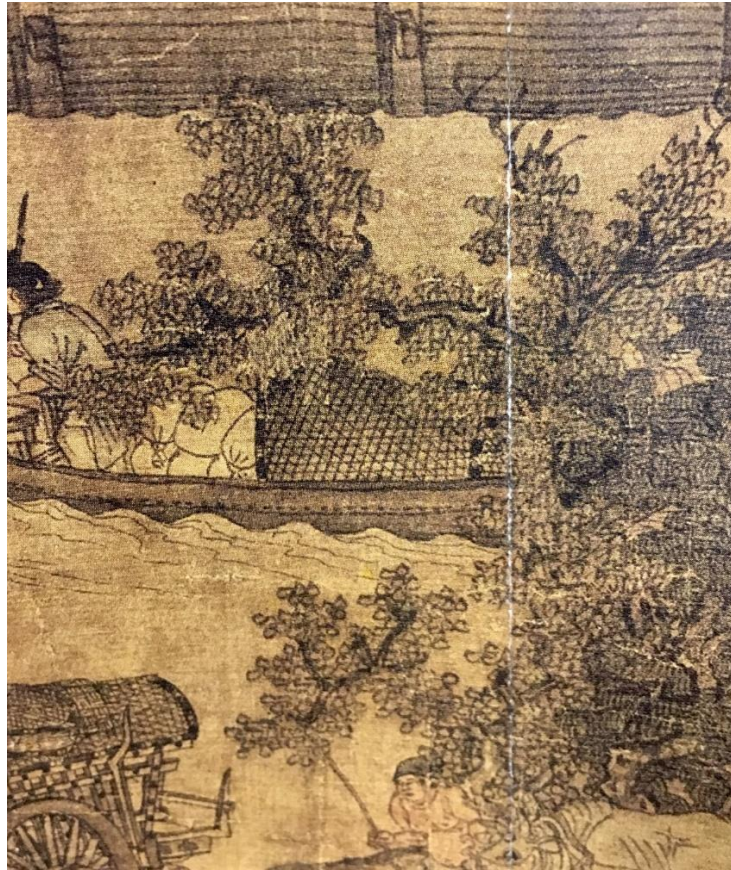


Figure 100
Detail of *The Water Mill*, the round-leaved plant



Figure 101
leaves of a *cotinus coggygria*
Photo by Yang Yan, Jinan city, Shandong province
(Image from frps.eflora.cn/frps?id=%E9%BB%84%E6%A0%8C)



Figure 102
The dark-leaved trees in *The Water Mill*



Figure 103
Detail of *The Water Mill*



Figure 104
Detail of *The Water Mill*



Figure 105

Detail of *The Early Spring* (1072)

Guo Xi (ca. 1000–1087)

Ink and colours on silk, 158.3 x 108.1 cm

National Palace Museum, Taipei

(Image from painting.npm.gov.tw/Painting_Page.aspx?dep=P&PaintingId=47)



Figure 106

Detail of *Travellers Among Mountains and Streams*,
Fan Kuan (ca. 950–1032)

Ink on silk, 206.3 x 103.3 cm

National Palace Museum, Taipei

(Image from painting.npm.gov.tw/Painting_Page.aspx?dep=P&PaintingId=1195)



Figure 107
Detail of *Travellers Among Mountains and Streams*



Figure 108

Detail of *The Water Mill*, two officials under the pavilion

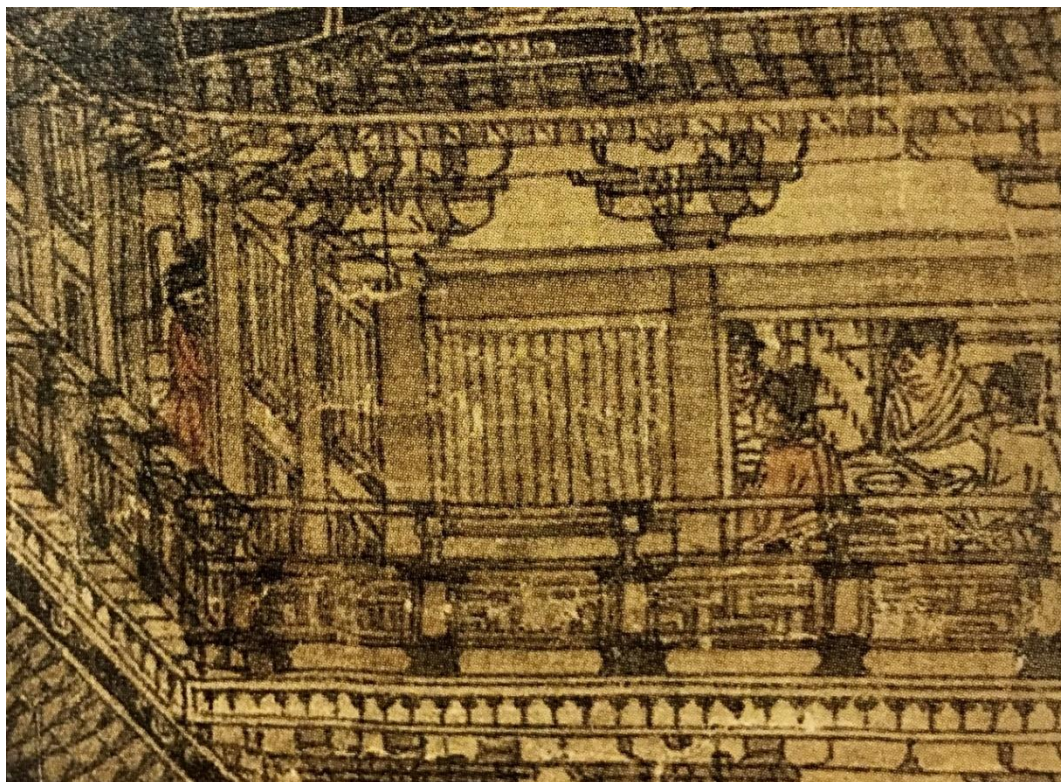


Figure 109

Detail of *The Water Mill*, five officials at the tavern

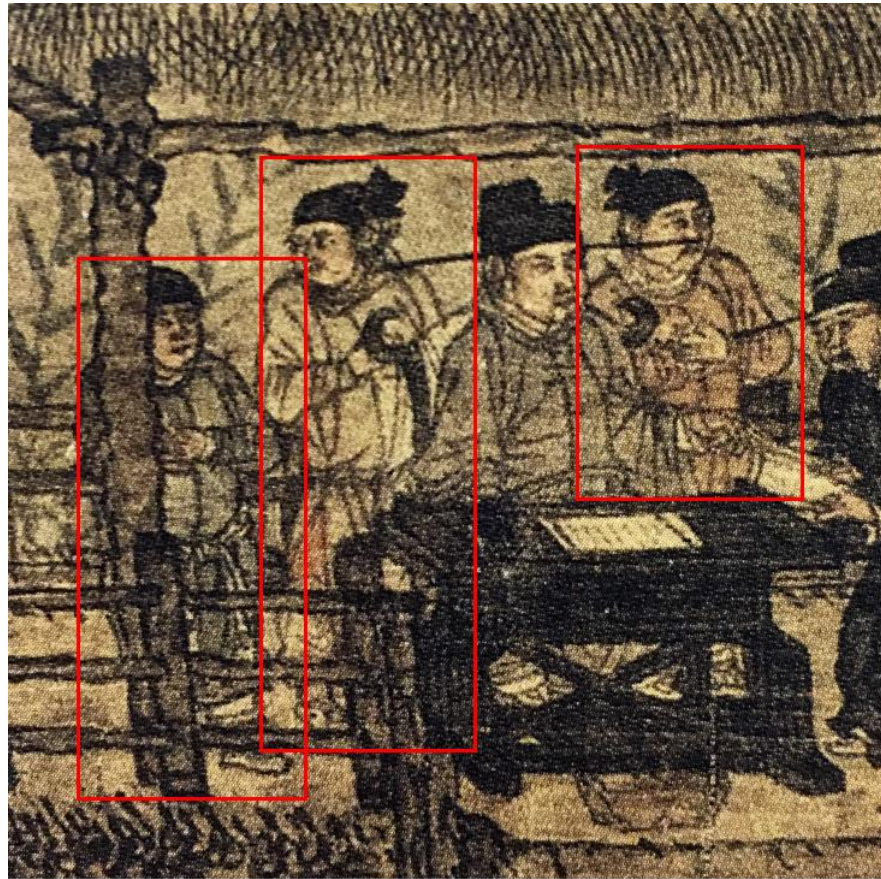


Figure 110

Detail of *The Water Mill*, the three junior officials under the pavilion



Figure 111

Detail of *The Water Mill*, a supervisor at the left terrace



Figure 112
Ordinary workers in *The Water Mill*

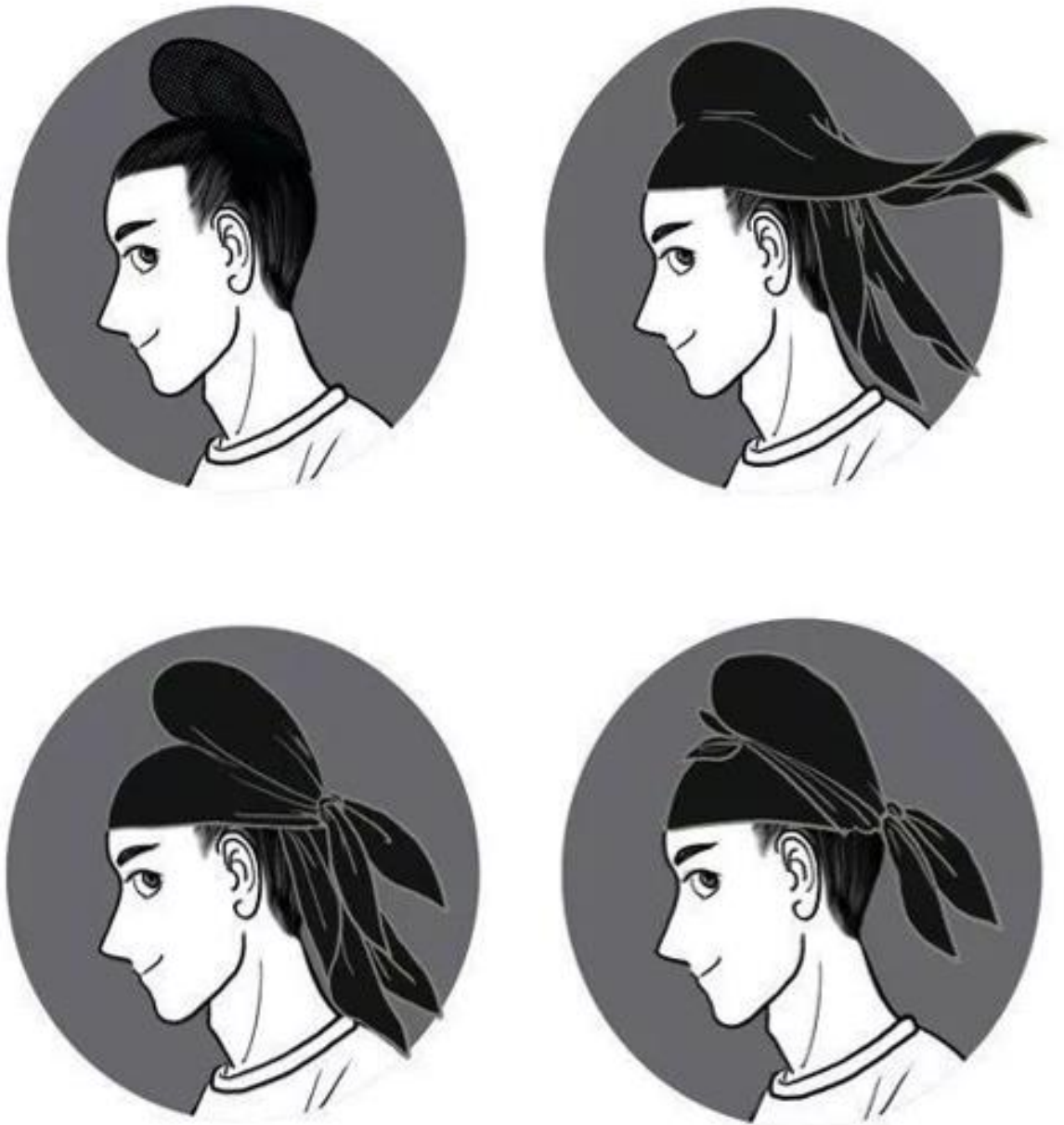


Figure 113
How to wear a *futou* (early Tang style)
(Image painted by Yanwang)

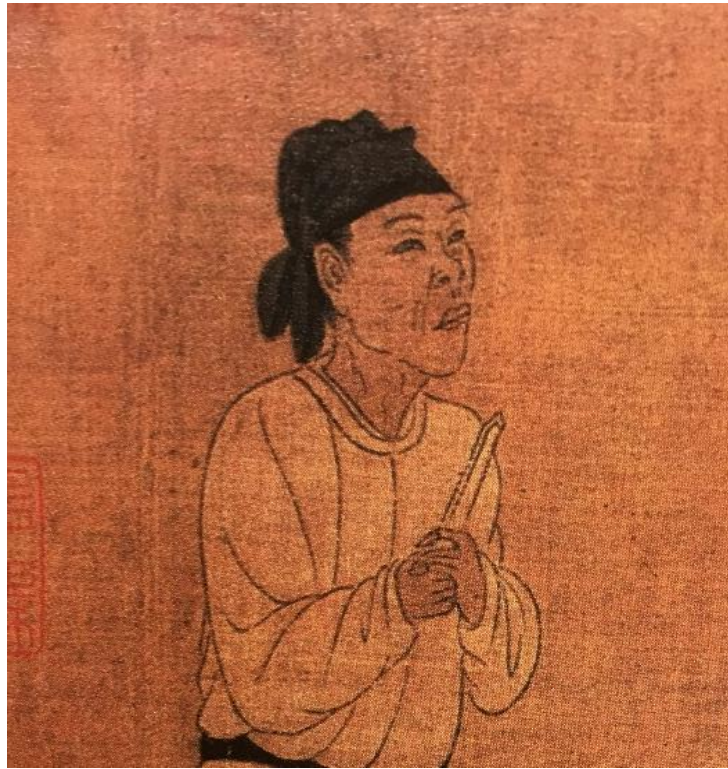


Figure 114

Detail of *Emperor Taizong Receiving the Tibetan Envoy*, the *futou* of a retinue
(Image from ZGMSQJ, Painting Collection vol 2, 7)



Figure 115

The *futou* of a servant
mural painting, in the tomb of Wei Gui (597–665) in the Zhao Mausoleum

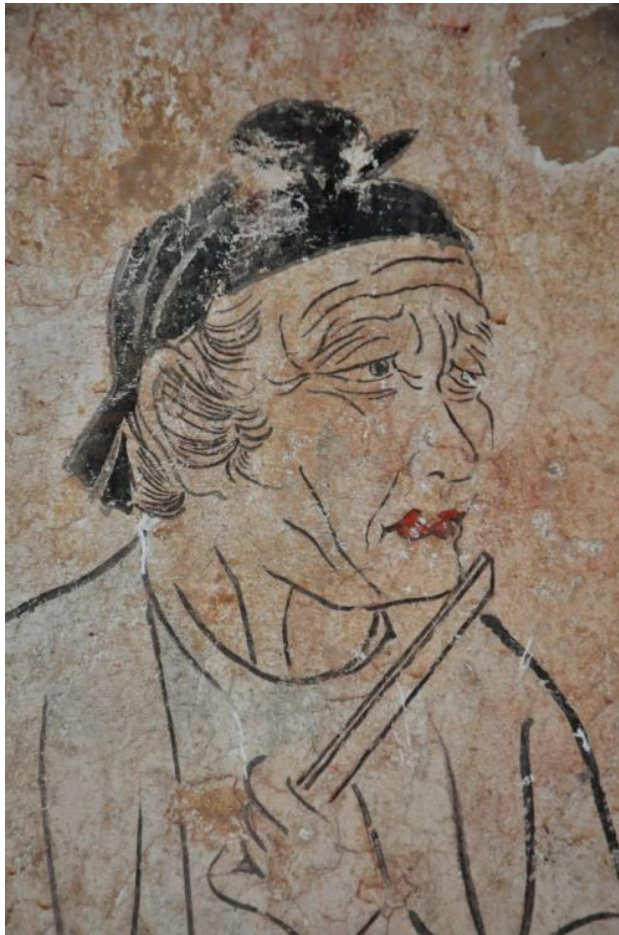


Figure 116
The *futou* of a servant
mural painting, in the tomb of the Princess Changle (621–643) in the Zhao Mausoleum



Figure 117
The *futou* of servants, mural painting, in the tomb of Li Shou (577–630)



Figure 118
The *futou* of a servant
mural painting, in the tomb of Wei Jiong (677–692)
(Image from ZGMSQJ, Painting Collection vol 12, 117)



Figure 119

Unknown

The Portrait of The Taizu Emperor of The Song Dynasty

ink and colours on silk, 191 x 169.7 cm

National Palace Museum, Taipei

(Image from painting.npm.gov.tw/Painting_Page.aspx?dep=P&PaintingId=1864)



Figure 120

Unknown

Story Handscroll (Renwu gushi tujuan 人物故事圖卷)

colours on silk, 26.7 x 142.2 cm

Shanghai Museum, Shanghai

(Image from www.jsy-sz.com/plus/view.php?aid=3128)



Figure 121

The line drawing of *Story Handscroll*, the straight tails *futou* of an official (front)
(Image from *The History of Ancient Chinese Costume*, 271)



Figure 122

The line drawing of *Story Handscroll*, the straight tails *futou* of an official (back)
(Image from *The History of Ancient Chinese Costume*, 271)



Figure 123
The *futou* of a drama actor
brick carving image, Song
a tomb in Jiuliugou County, Yanshi, Henan province
(Image from *The Ancient Chinese Clothing Research*, 438)

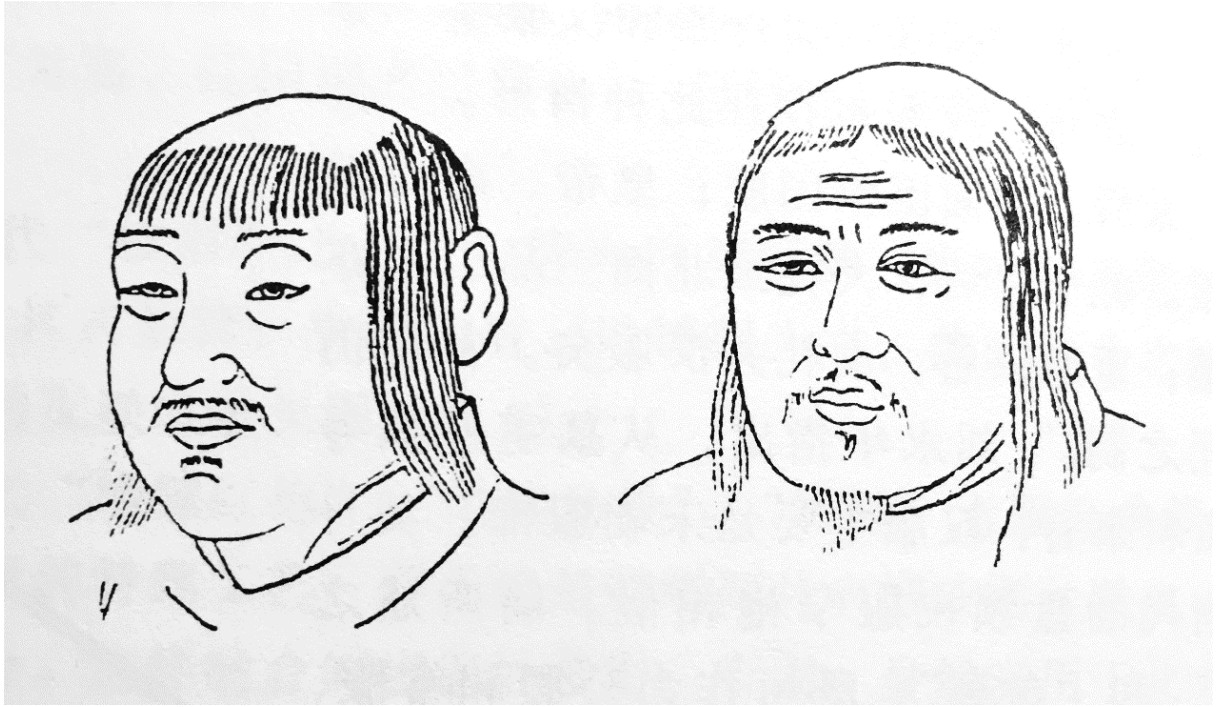


Figure 124

The *kunfa* of the Liao Dynasty

line drawing of the mural painting, from the eastern tomb of the Qing Mausoleum

(Image from *History of The Aesthetics of Chinese Dress*, 694)

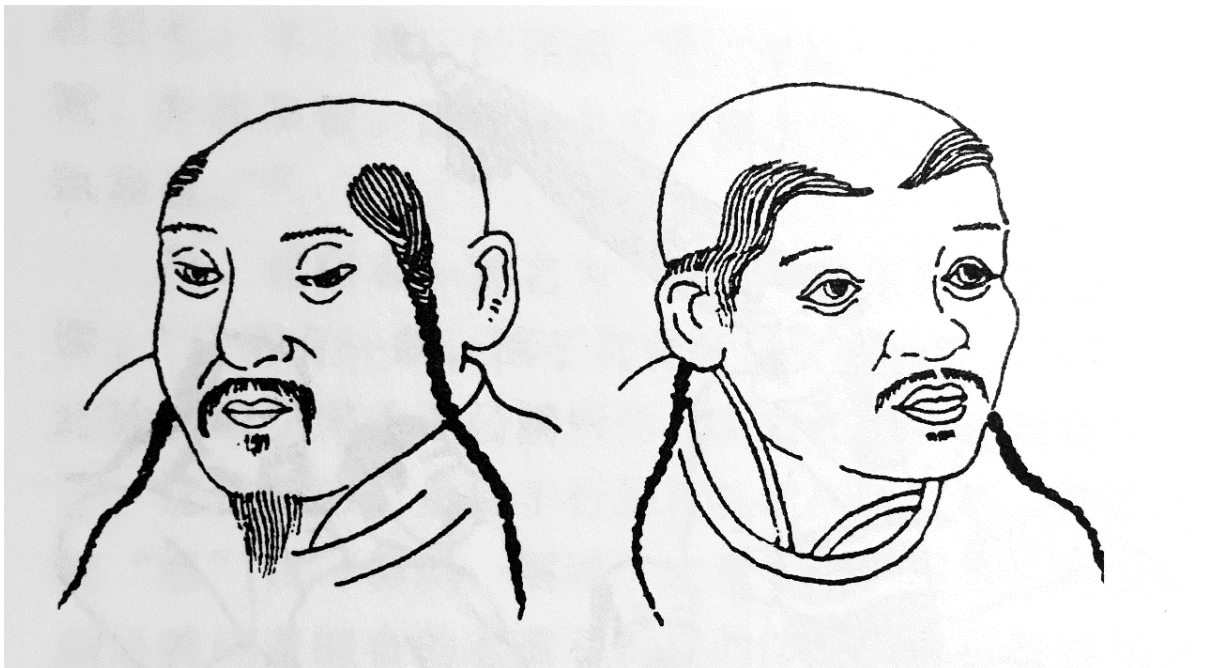


Figure 125

The *kunfa* of the Liao Dynasty

line drawing of the mural painting

from No.6 tomb of the Former Bolibog Mausoleum, Hure Banner, Inner Mongolia

(Image from *History of The Aesthetics of Chinese Dress*, 694)



Figure 126
The curving tails *futou* of performers
mural painting, Liao Dynasty Mausoleum
Xuanhua County, Zhangjiakou, Hebei province



Figure 127

The *jinxian* hat

line drawing of the mural painting, late Eastern Han
from the Yinan tomb, Yinan County, Linyi, Shandong province
(Image from *The History of Ancient Chinese Costume*, 85)

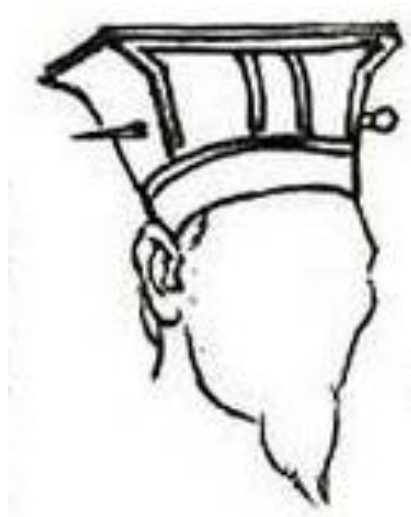


Figure 128

The *xiezhi* hat

(Image from

baike.baidu.com/item/%E7%8D%AC%E8%B1%B8%E5%86%A0/10796278?sefr=cr)



Figure 129
The straight tails *futou* of the Yuan Dynasty
(Illustration from *Quanxiang pinghua wuzhong*, vol 2)



Figure 130
Unknown
The Portrait of Wang Ao
Ming, colours on paper, 161.6 x 96.1 cm
Nanjing Museum, Nanjing
(Image from news.artron.net/20170826/n952913_3.html)

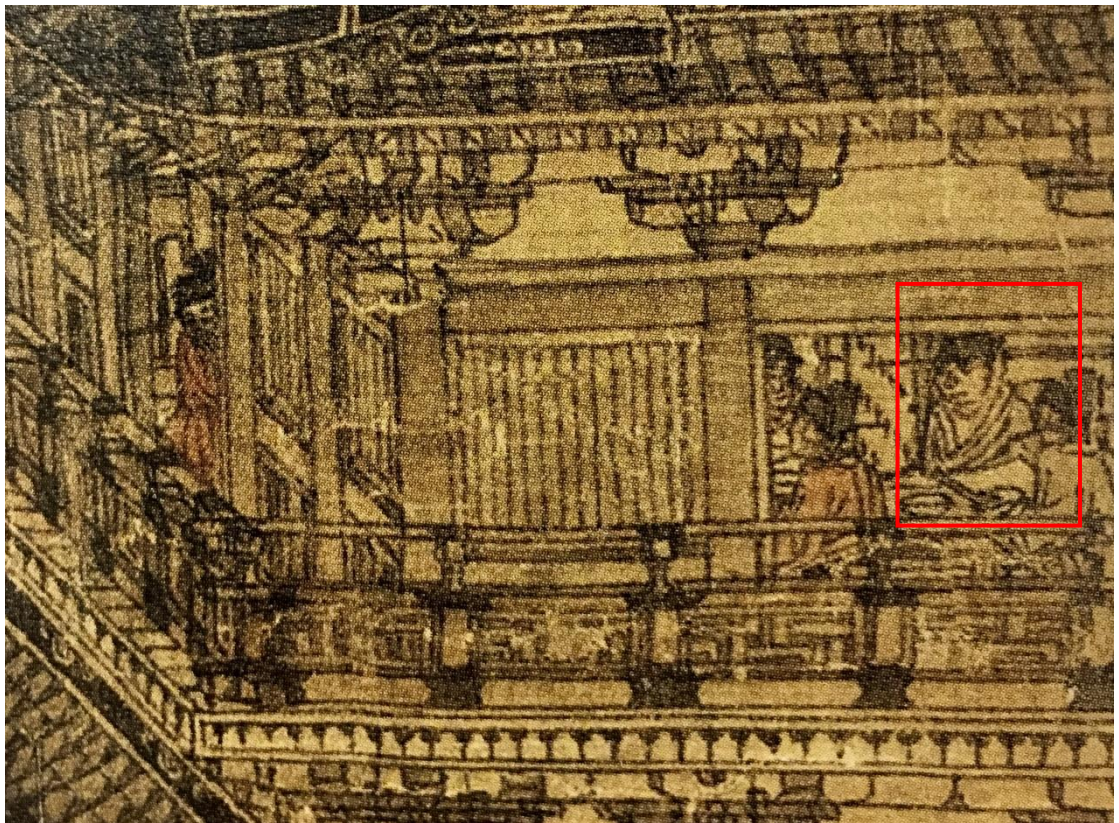


Figure 131

Detail of *The Water Mill*, the Y-neck right lapel garment of an official

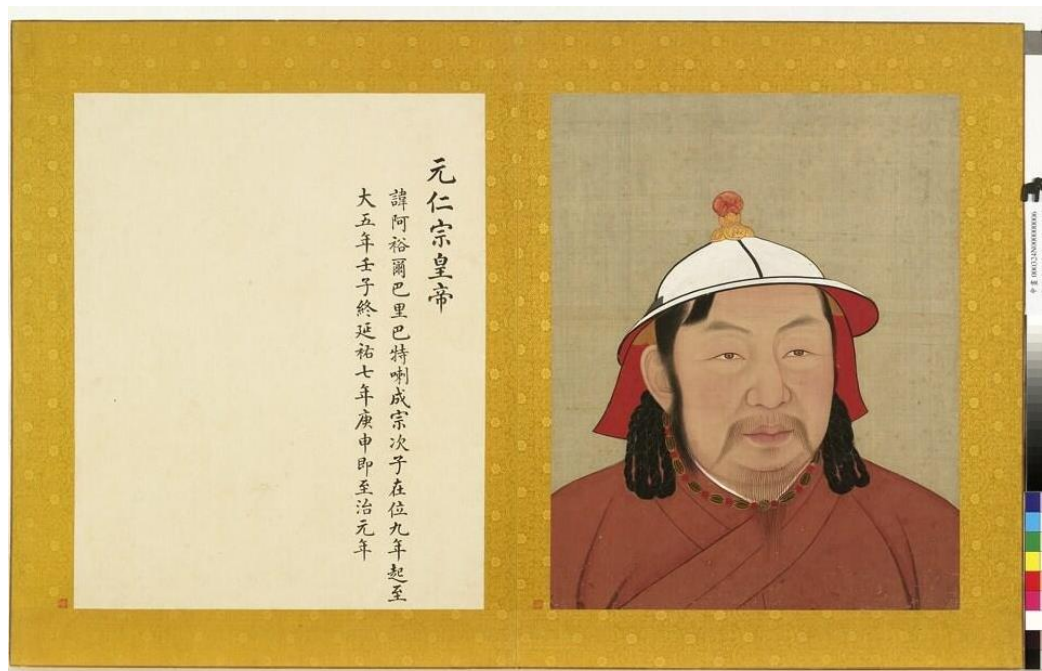


Figure 132

Unknown

The Portrait of the Renzong Emperor of the Yuan Dynasty

colours on silk, 59.2 x 47 cm

National Palace Museum, Taipei

(Image from painting.npm.gov.tw/Painting_Page.aspx?dep=P&PaintingId=15492)



Figure 133

Unknown

The Portrait of the Shizu Empress of the Yuan Dynasty

colours on silk, 61.5 x 48 cm

National Palace Museum, Taipei

(Image from painting.npm.gov.tw/Painting_Page.aspx?dep=P&PaintingId=15495)



Figure 134

The right lapel garment maidservants
mural painting, Yuan, in a tomb in Shuozhou, Shanxi province
(Image from shanxi.sina.com.cn/news/s/2019-06-20/detail-ihycitk6470165.shtml)



Figure 135

The right lapel garment figures
mural painting, Yuan, in Yongle Palace, Ruicheng County, Yuncheng, Shanxi province
(Image from wenzhengwenhua.com/article-3224-1.html)



Figure 136

Detail of *Zhuoxie Tu*, females in the left lapel robes
Attributed to Hu Huan (Liao Dynasty)

Jin, colours on silk, 33 x 256 cm

Palace Museum, Beijing

(Image from www.dpm.org.cn/collection/paint/234629.html)



Figure 137
The left lapel garment figures
mural painting, Yuan, in Yongle Palace
Ruicheng County, Yuncheng, Shanxi province



Figure 138
The left lapel garment figures
mural painting, Yuan, in Yongle Palace
Ruicheng County, Yuncheng, Shanxi province

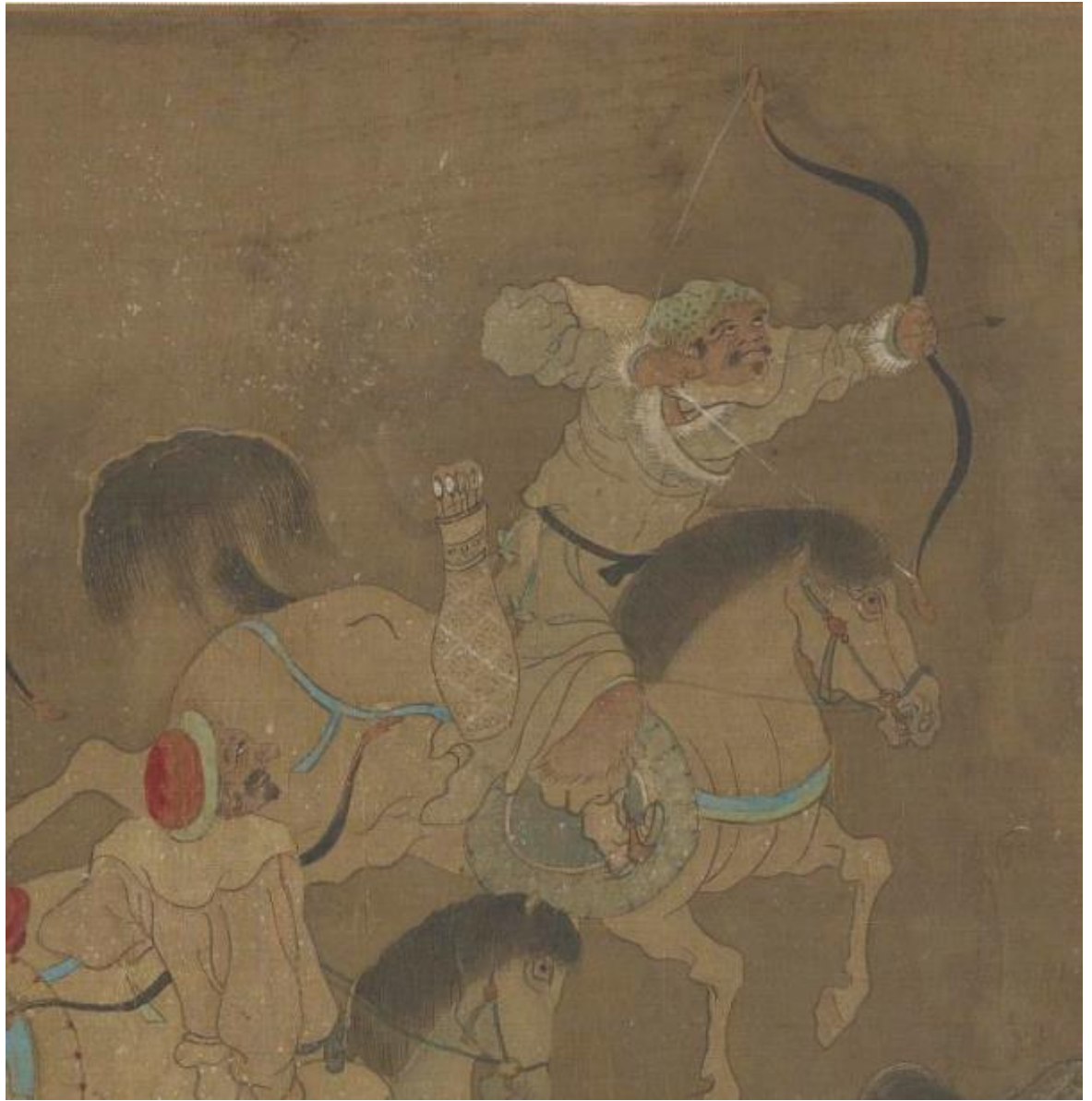


Figure 139

Detail of *Tartar Huntsmen in the Snow*, a huntsman in the left lapel garment
Hu Huan (attrib.)

Liao, ink and colours on silk, 28.8 x 117 cm

Freer Gallery of Art, Washington, D.C.

(Image from asia.si.edu/object/F1916.406/)



Figure 140
The right and left label figures
mural painting, Liao, in a tomb in Xuanhua, Zhangjiakou, Hebei province



Figure 141
The right and left label figures
mural painting, Liao, in a tomb in Xuanhua, Zhangjiakou, Hebei province



Figure 142

The right and left lapel figures

mural painting (ca. 1298), Yuan, from the Xinghua Temple, Jishan County, Shanxi province
currently collected in the Royal Ontario Museum, Toronto

(Image from collections.rom.on.ca/objects/335520/the-paradise-of-maitreya-wallpainting?ctx=1aace446-f9c2-4ed7-bbb5-b05bd8c2d467&idx=0)



Figure 143

Unknown

Ten Same Year (Scholars) Painting

Ming, colours on silk, 48.5 x 257 cm

Palace Museum, Beijing

(Image from www.dpm.org.cn/collection/paint/230242.html)



Figure 144
Unknown

The Portrait of Huang Yue in the Formal Dress
Qing, colours on silk, 112.7 x 56.4 cm
Palace Museum, Beijing
(Image from www.dpm.org.cn/collection/paint/234909.html)



Figure 145

Civilian officials in round-collared, narrow-sleeved robes
Mural painting of the tomb of Li Chongrun (The Yide Prince), Tang Dynasty
Qian county, Shanxi province
(Image from *5000 years of Chinese costumes*, 92.)



Figure 146
Unknown,
The Portrait of the Renzong Emperor
Northern Song, colours on silk, 188.5 x 128.8 cm
National Palace Museum, Taipei
(Image from painting.npm.gov.tw/Painting_Page.aspx?dep=P&PaintingId=1832)



Figure 147

Detail of *Along the River During the Qingming Festival*, figures wearing black kerchiefs



Figure 148

Detail of *Along the River During the Qingming Festival*, figures wearing black kerchiefs

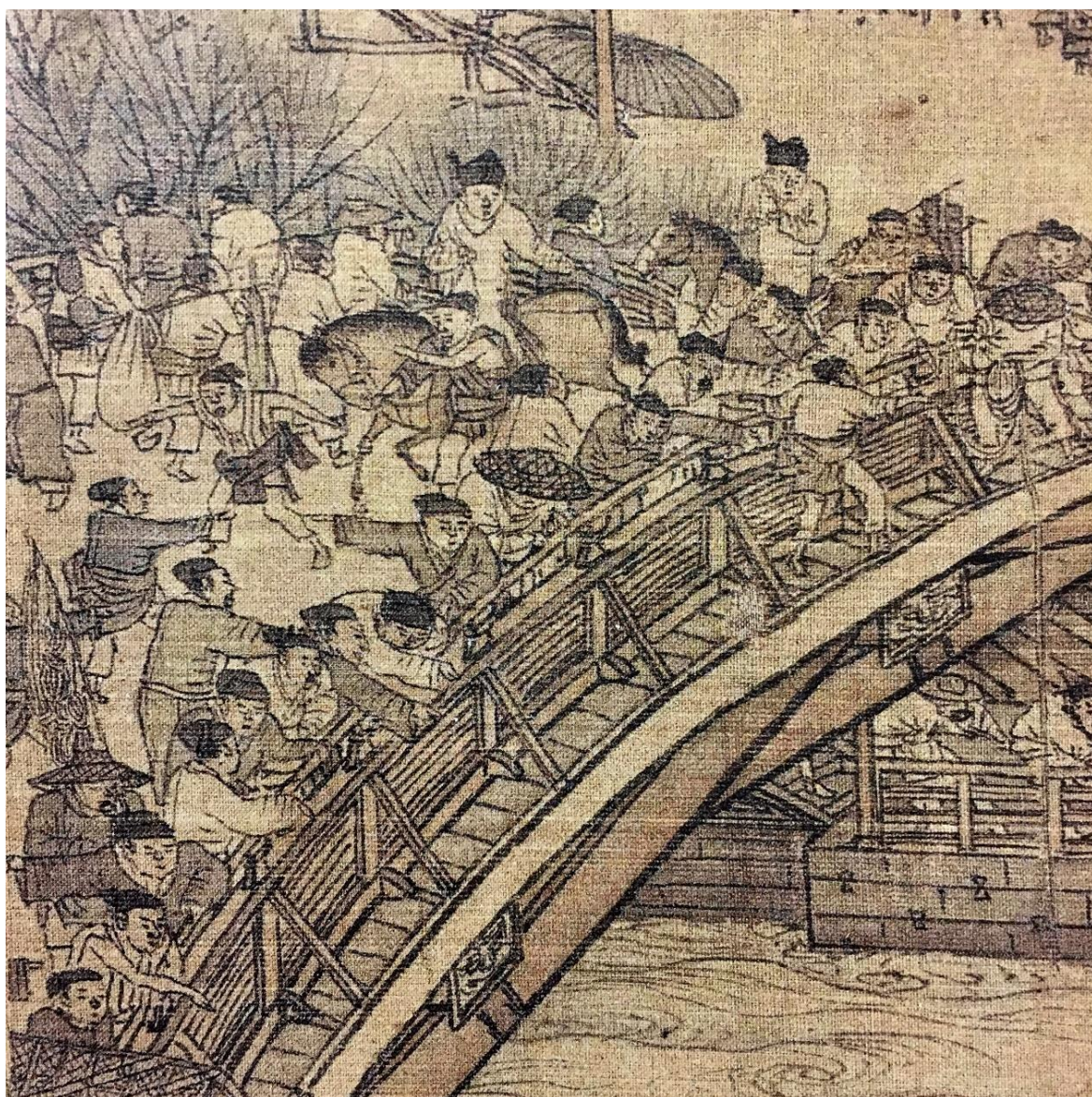


Figure 149

Detail of *Along the River During the Qingming Festival*, figures wearing black kerchiefs



Figure 150

Detail of *Along the River During the Qingming Festival*, figures wearing black kerchiefs

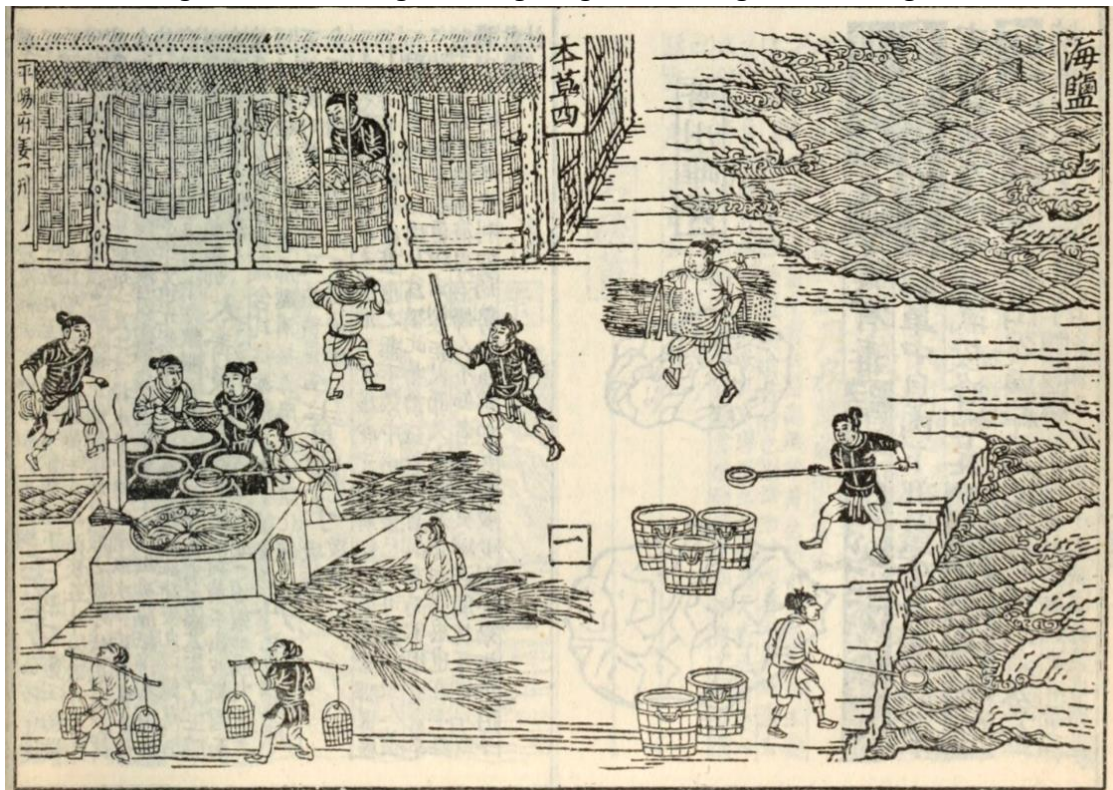


Figure 151

Figures wearing black kerchiefs, Jin
from *CXZHJSZLBYBC* (ca.1249), vol 4

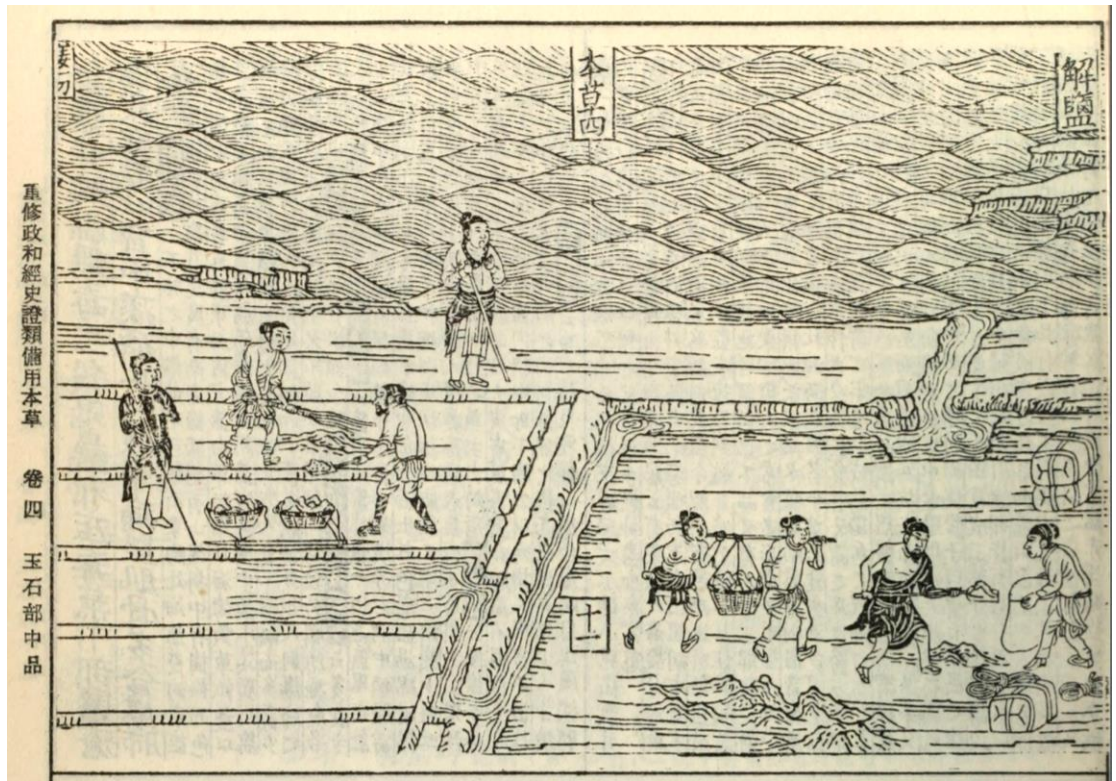


Figure 152
 Figures wearing black kerchiefs, Jin
 from CXZHJSZLBYBC (ca.1249), vol 4

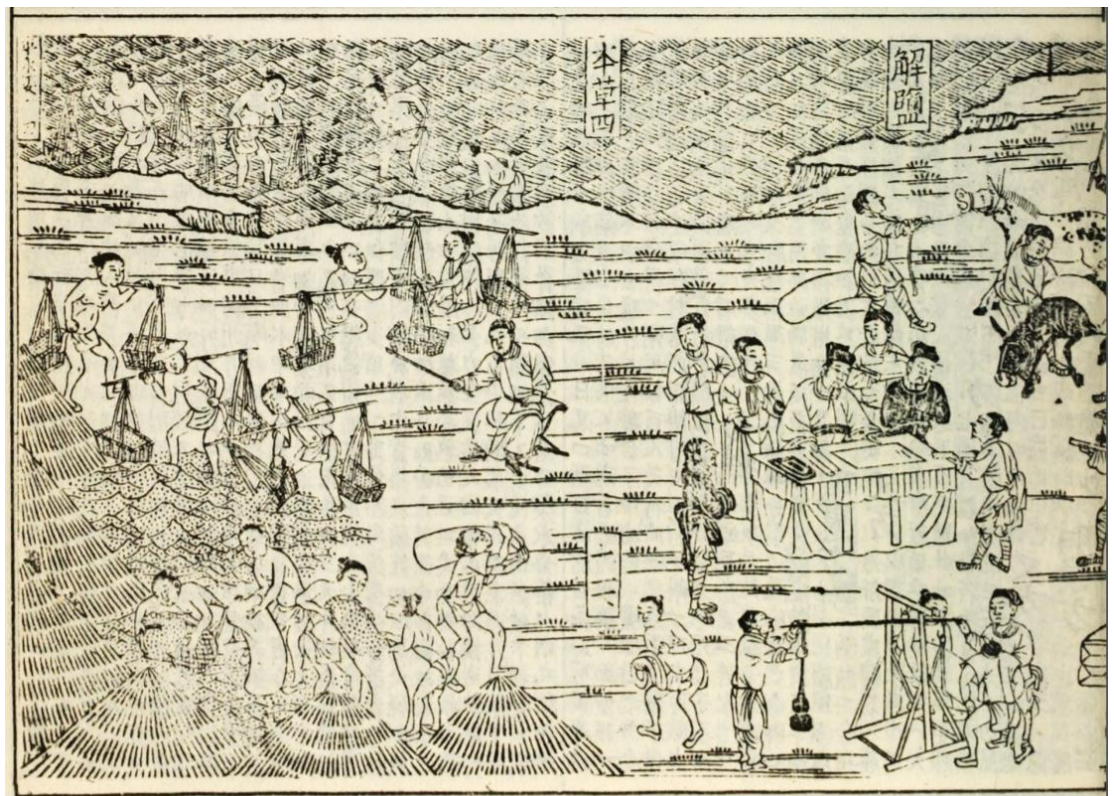


Figure 153
 Figures wearing black kerchiefs, Jin
 from CXZHJSZLBYBC (ca.1249), vol 4



Figure 154

Figures wearing black kerchiefs, Yuan
from *Quanxiang pinghua wuzhong*



Figure 155

Detail of *Along the River During the Qingming Festival* (Ming Dynasty),
figure in cuboid cloth hat

Qiu Ying (attrib.)

colours on silk, 30.5 x 987 cm

Liaoning Provincial Museum, Shenyang

(Image from

baike.baidu.com/item/%E6%B8%85%E6%98%8E%E4%B8%8A%E6%B2%B3%E5%9B%BE/2321783?fr=aladdin)

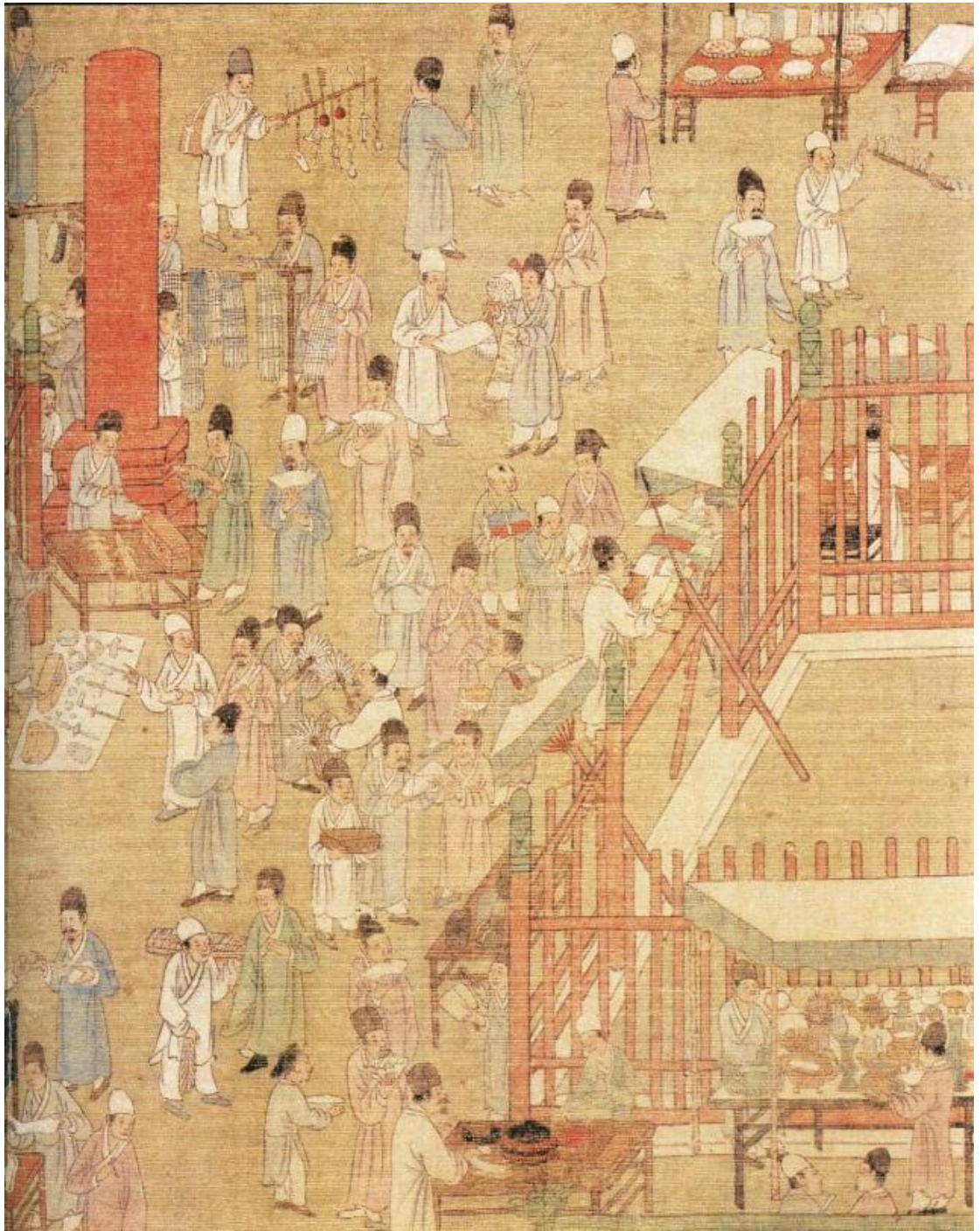


Figure 156

Detail in *Painting Scroll of Prosperity in the Imperial Capital*, figures in skull hats

Anonymous, Ming

Colours on silk, 32 x 2182.6 cm

National Museum of China, Beijing

(Image from www.chnmuseum.cn/zp/zpml/201812/t20181218_25376.shtml)



Figure 157
Figures wearing *wangjin*, Ming
(Image from *Tiangong kaiwu*)



Figure 158
Figures wearing *wangjin*, Ming
(Image from *Tiangong kaiwu*)



Figure 159
Figures wearing *quekuashan*
mural painting, Liao Dynasty Mausoleum
Xuanhua County, Zhangjiakou, Hebei province



Figure 160
Figures wearing *quekuashan*, from *Quanxiang pinghua wuzhong* (Yuan)



Figure 161
The *chashou li* figure
mural painting, in the tomb of Zhao Yigong, Tang
An'yang, Henan province

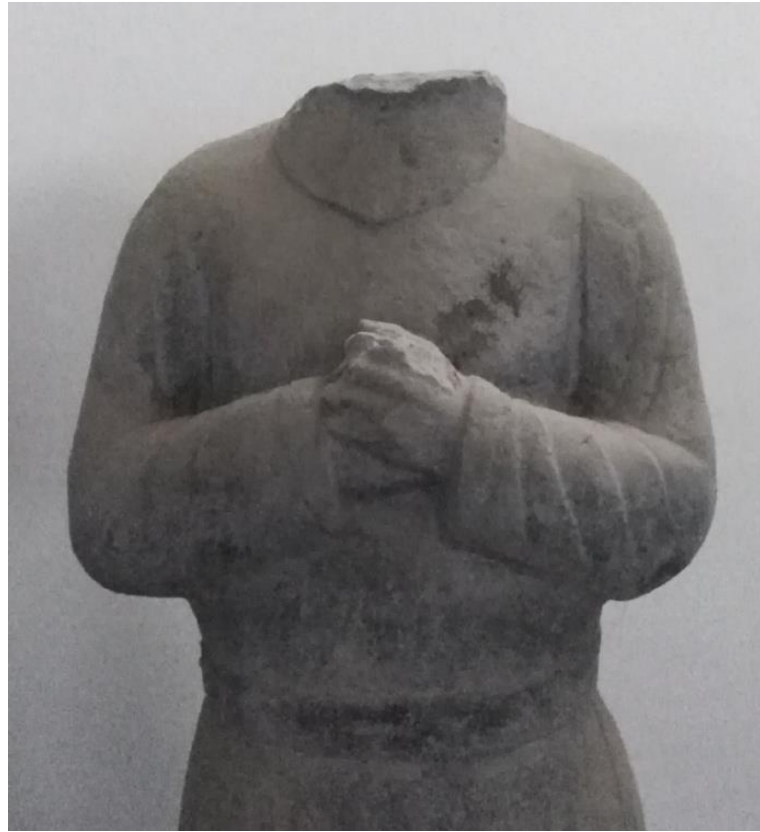


Figure 162
The *chashou li* figure
sculpture, in the Qianling Mausoleum, Tang
Qian County, Shanxi province



Figure 163
The *chashou li* figures
mural painting, in the tomb of Mengjing Xinzhuang, Five Dynasties
Luoyang, Henan province

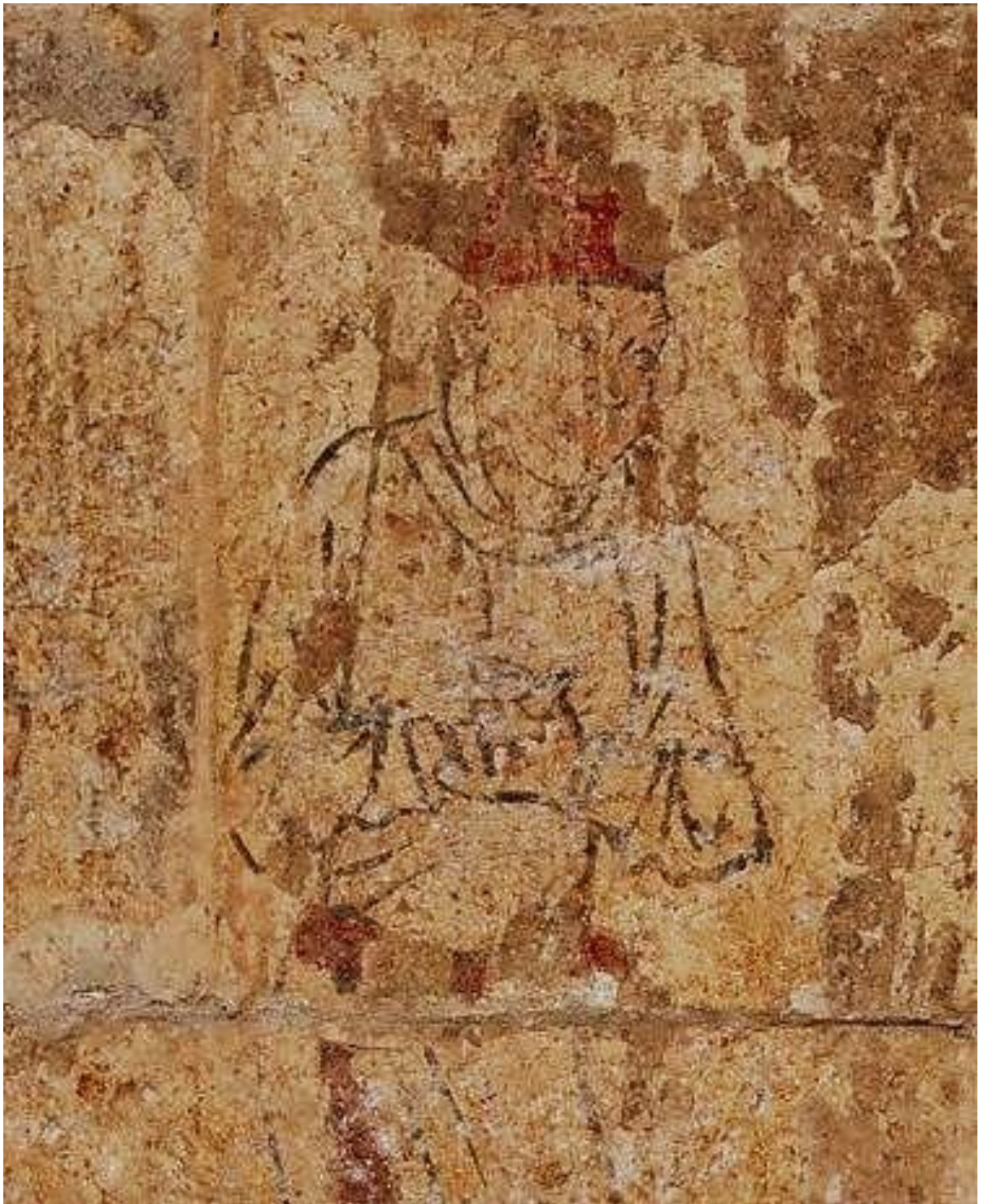


Figure 164
The *chashou li* figure
mural painting, in a Song tomb
Luoyang, Henan province



Figure 165

The *chashou li* ritual, from *Shilin guangji*, Southern Song



Figure 166
Group a of the common people, in *The Water Mill*



Figure 167
Group b of the common people, in *The Water Mill*

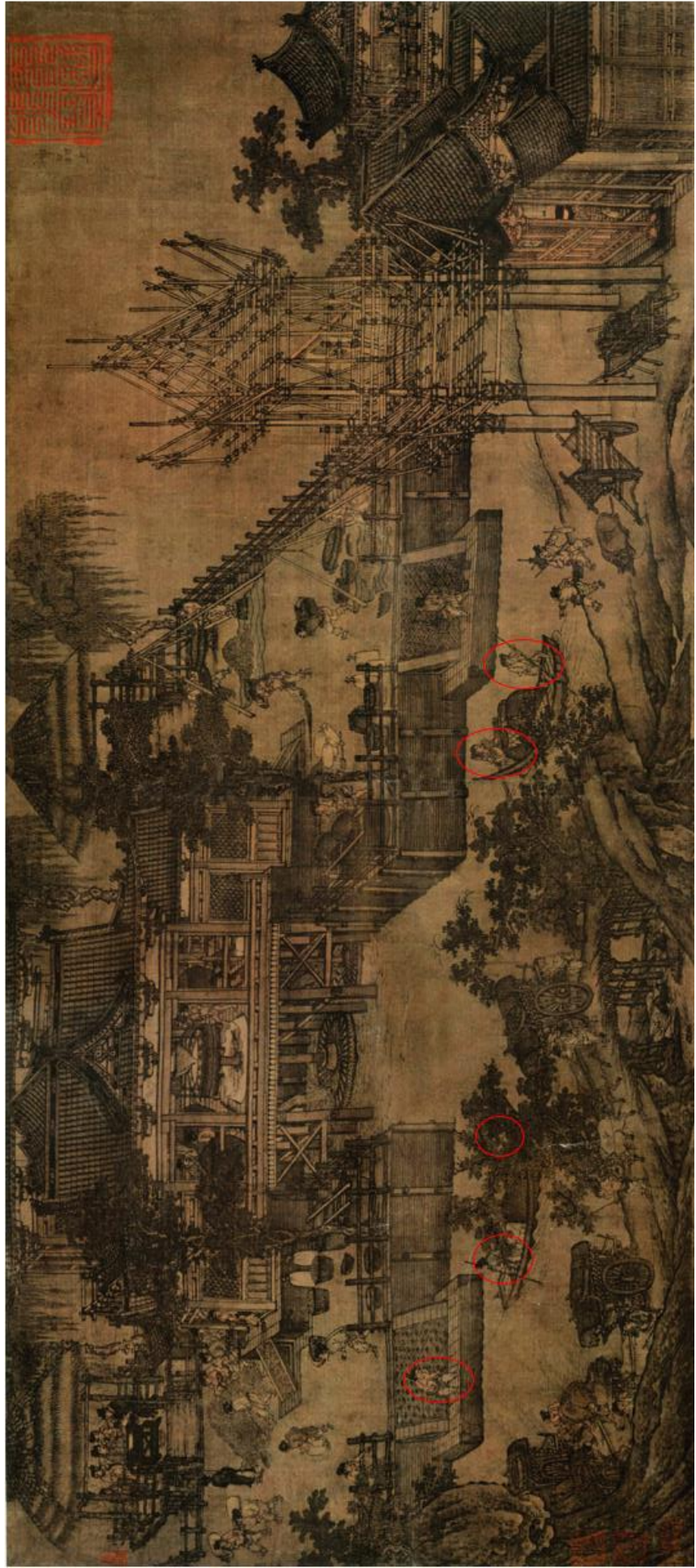


Figure 168
Group c of the common people, in *The Water Mill*



Figure 169
Group d of the common people, in *The Water Mill*



Figure 170

Detail of *The Water Mill*, the common people in *quekuashan*



Figure 171

Detail of *The Water Mill*, the common people in *quekuashan*



Figure 172

Detail of *The Water Mill*, the common people in *quekuashan*

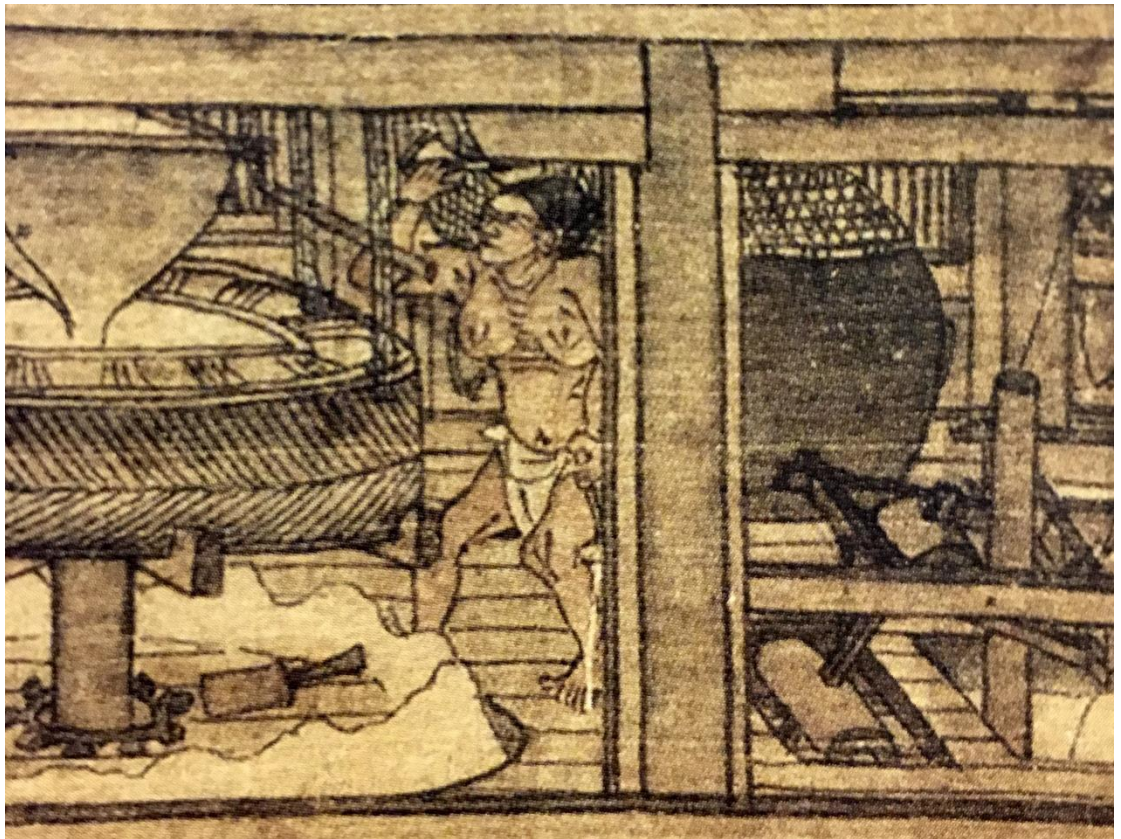


Figure 173

Detail of *The Water Mill*, the topless labourer



Figure 174
Detail of *The Water Mill*, the labourer in a waistcoat



Figure 175
Detail of *Along the River During the Qingming Festival*, the workers in waistcoats



Figure 176

Detail of *Along the River During the Qingming Festival*, the workers in waistcoats



Figure 177

Detail of *Along the River During the Qingming Festival*, the workers in waistcoats



Figure 178
Harvesting
cave 445 (the glorious age of Tang), Dunhuang, Gansu province

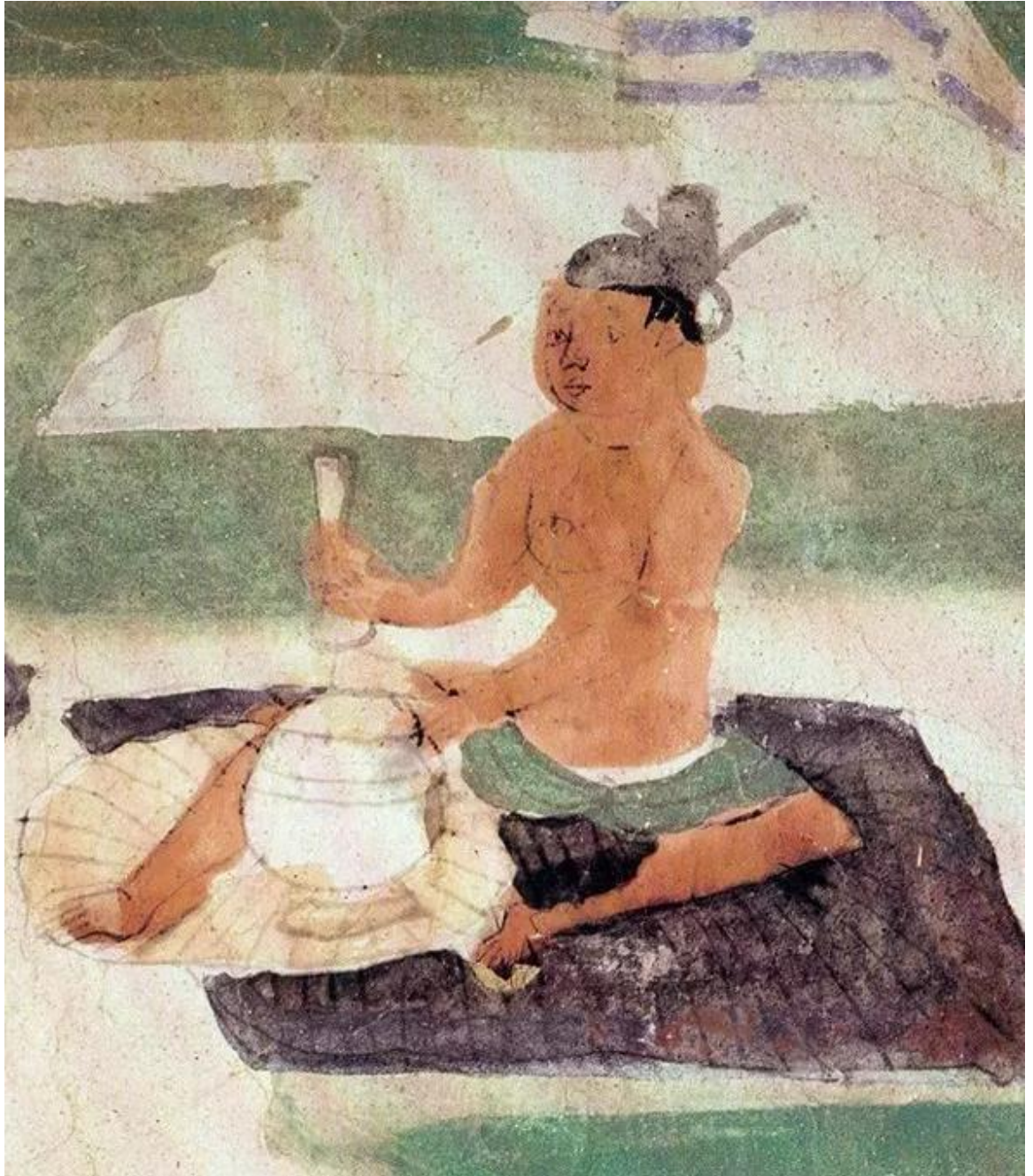


Figure 179

Potting

cave 61 (Five Dynasties), Dunhuang, Gansu province



Figure 180
Building a Tower and Painting Murals
cave 296 (Northern Zhou), Dunhuang, Gansu province



Figure 181
Farmer wearing *banbi*, cave 23 (the north wall)
middle of Tang, Dunhuang, Gansu province
(Image from ZGMSQJ, Painting Collection vol 15, 67)

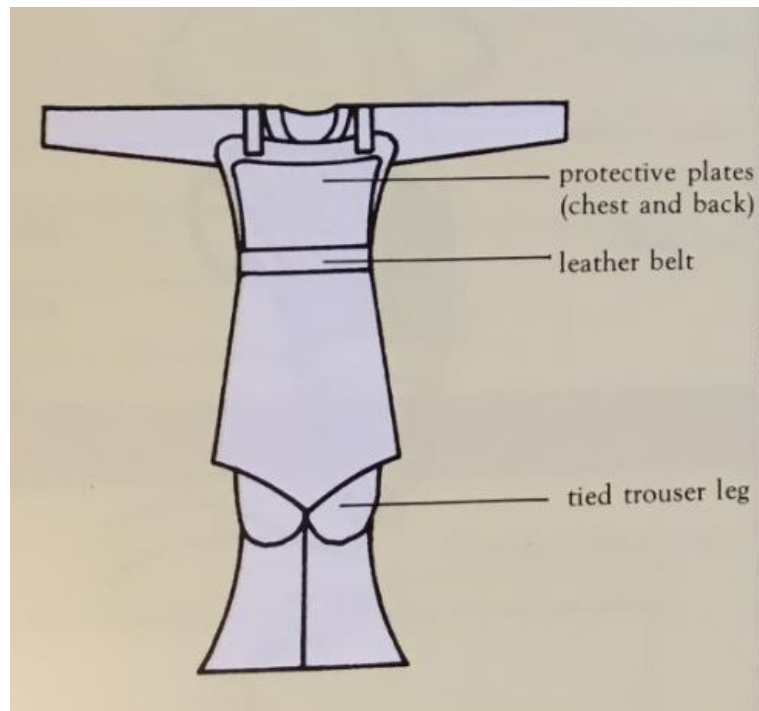


Figure 182
 The illustration of *liangdang*
 (Image from *5000 years of Chinese costumes*, 1987, 247.)



Figure 183
 Detail of *Northern Qi scholars collating classic texts*
 Anonymous, Northern Song (copy of the original painting of Northern Qi)
 Ink and colour on silk, 27.5 x 114cm
 Museum of Fine Arts, Boston
 (Image from collections.mfa.org/objects/29063)

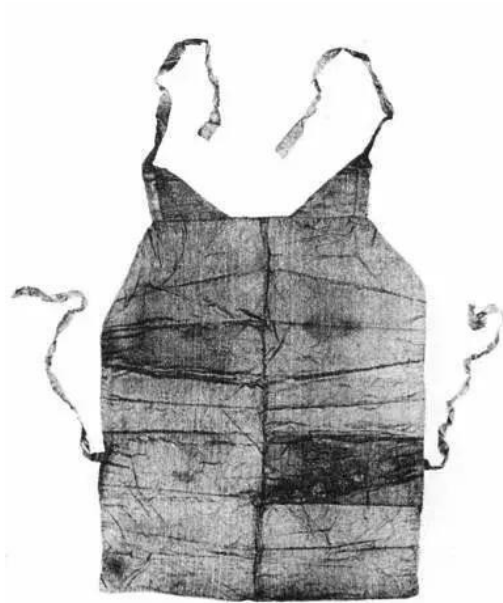


Figure 184
The bellyband, excavated from the tomb of Huang Sheng (female)
Southern Song, Fujian province
(Image from *Fuzhou Nansong Huang Sheng Mu*)

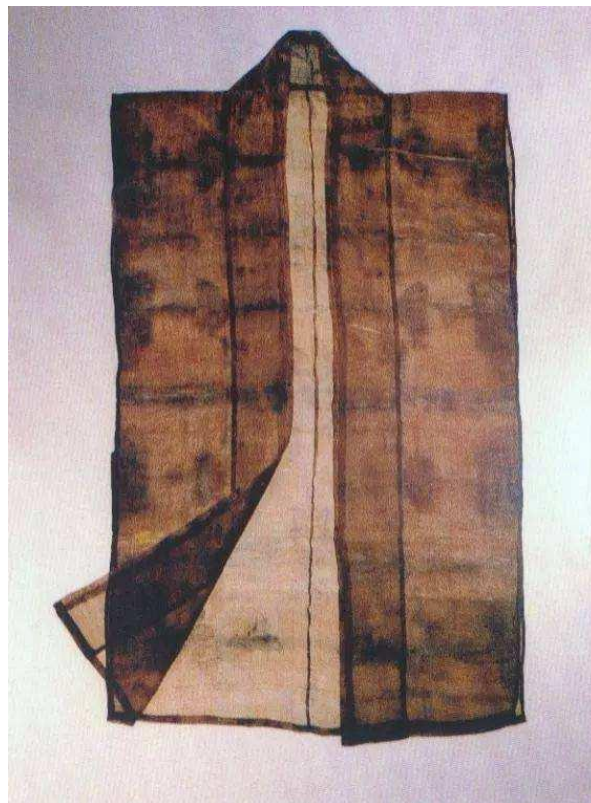


Figure 185
Waistcoat, excavated from the tomb of Huang Sheng (female)
Southern Song, Fujian province
(Image from *Fuzhou Nansong Huang Sheng Mu*)



Figure 186
Waistcoat, excavated from a Yuan tomb, Jiangsu province



Figure 187
Detail of *The Water Mill*, figures wearing split trousers



Figure 188

Detail of *The Water Mill*, figure wearing split trousers



Figure 189
Split trousers, excavated from the tomb of Huang Sheng (female)
Southern Song, Fujian province



Figure 190
Split trousers, excavated from the tomb of Zhou Yu (male)
Southern Song, Jintan, Jiangsu province



Figure 191
Detail of *The Water Mill*, figure wearing *dubikun*



Figure 192
Detail of *Along the River During the Qingming Festival*, figure wearing *dubikun*



Figure 193

Detail of *The Early Snow on the River*, figures wearing *dubikun*

Zhao Gan

Southern Tang, colours on silk, 25.9 x 376.5 cm

National Palace Museum, Taipei

(Image from painting.npm.gov.tw/Painting_Page.aspx?dep=P&PaintingId=51)



Figure 194

Scene of “Er yun 二耘 (The second Weeding)” from *Pictures of Tilling*
Cheng Qi (attrib., ca.1275). Later copy, possibly the 18th century
Handscroll, ink and colours on paper.
Freer Gallery of Art, Washington, D.C.
(Image from *Pictures of Tilling and Weaving*, 95.)



Figure 195

Detail of *One Hundred Horses*, figures wearing *dubikun*

Unknown, Song,

colours on silk, 26.7 x 302.1 cm

National Palace Museum, Taipei

(Image from tupian.baik.com/a1_83_62_01300000251577123790621107151_jpg.html)



Figure 196

Detail of *The Water Mill*, labourer with tattoo



Figure 197

Detail of *The Water Mill*, labourer with tattoo

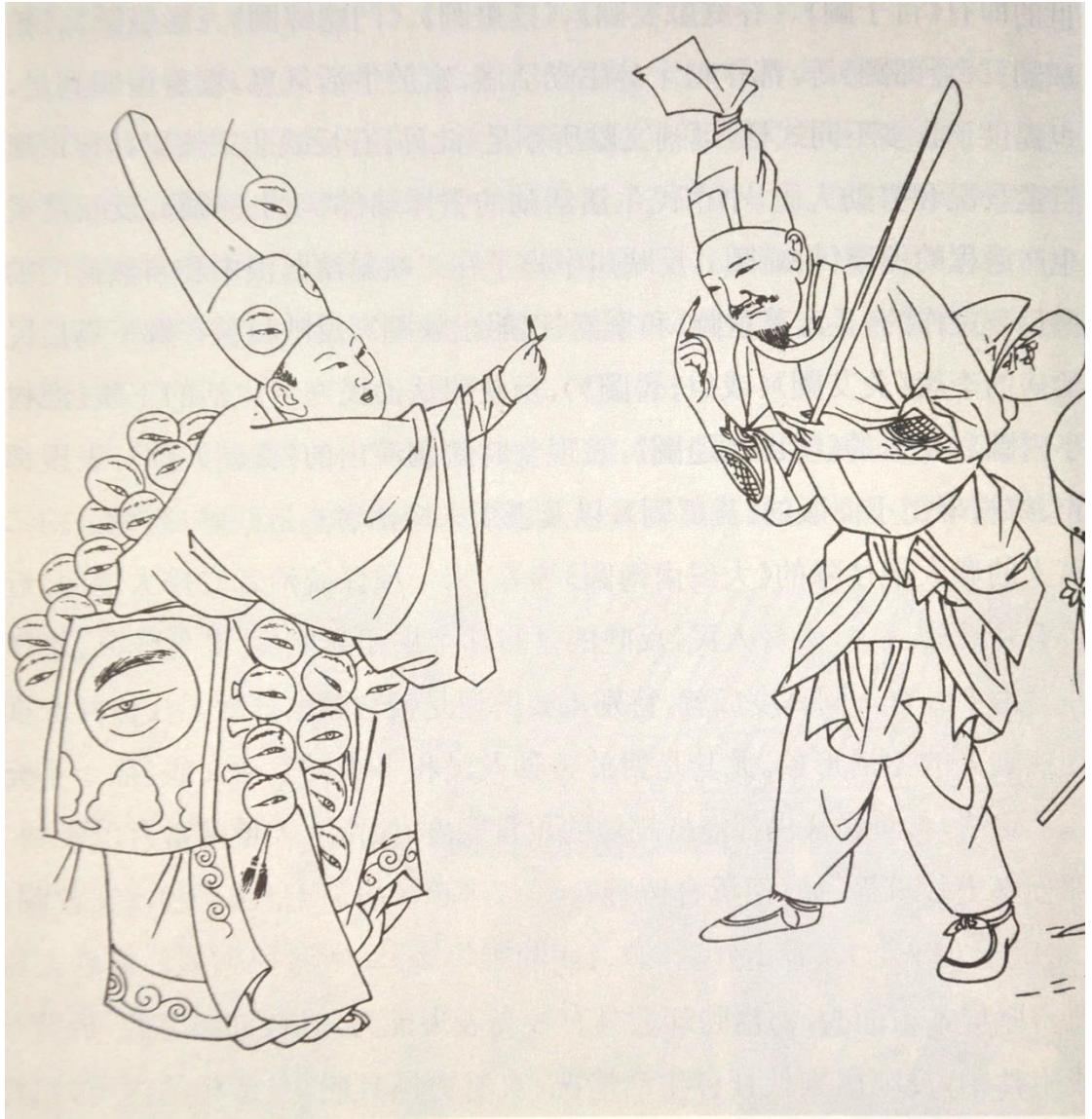


Figure 198
Figure with tattoo
from *Zaju renwu tu*, Song
Palace Museum, Beijing
(Image from *The Ancient Chinese Clothing Research*, 434)



Figure 199
Detail of *The Water Mill*, the decorative structure and the tavern

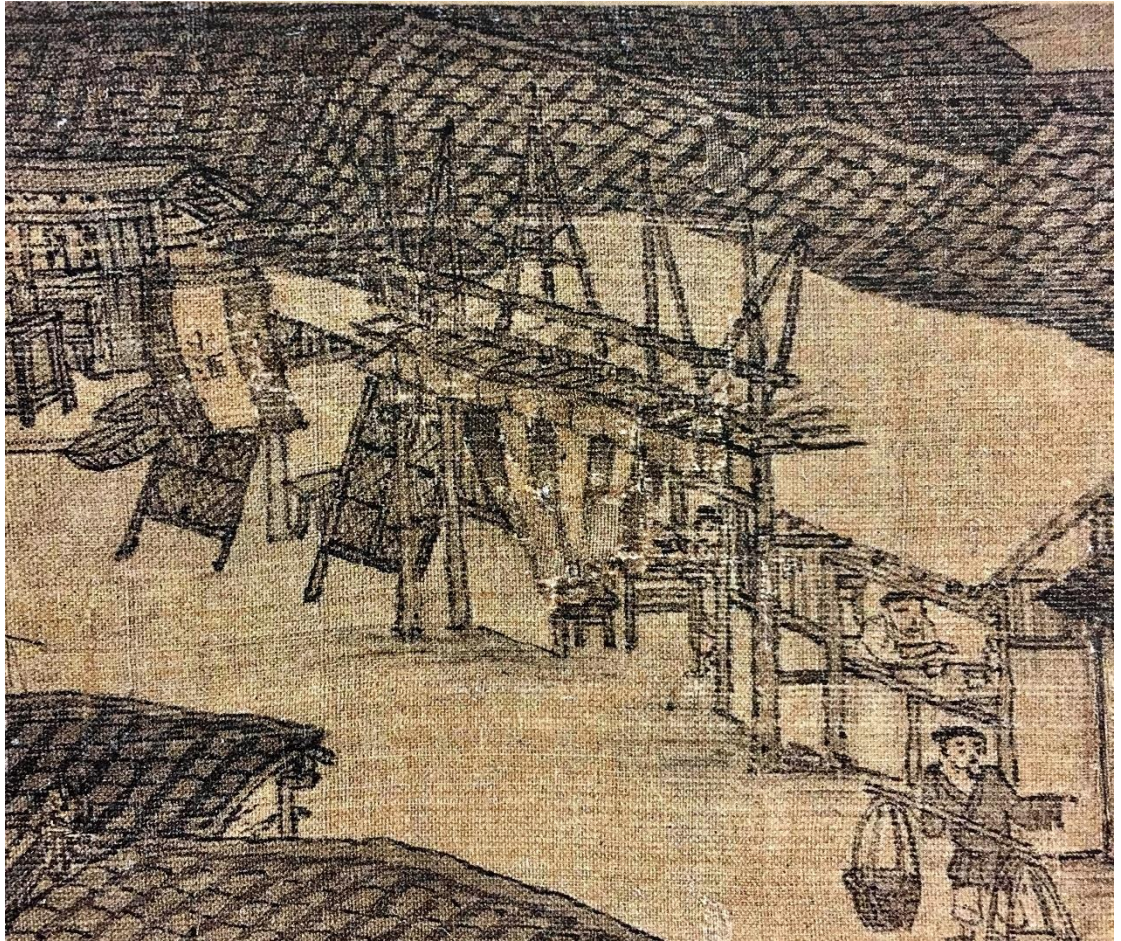


Figure 200

Detail of *Along the River During the Qingming Festival*, the decorative structure

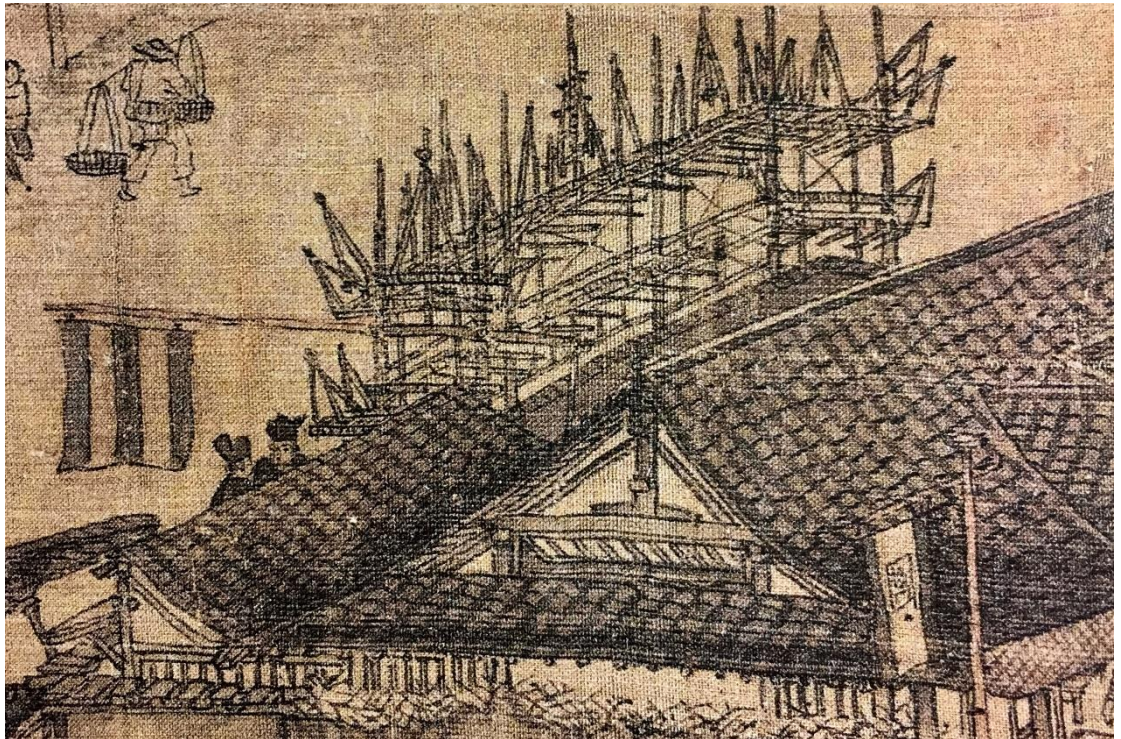


Figure 201

Detail of *Along the River During the Qingming Festival*, the decorative structure

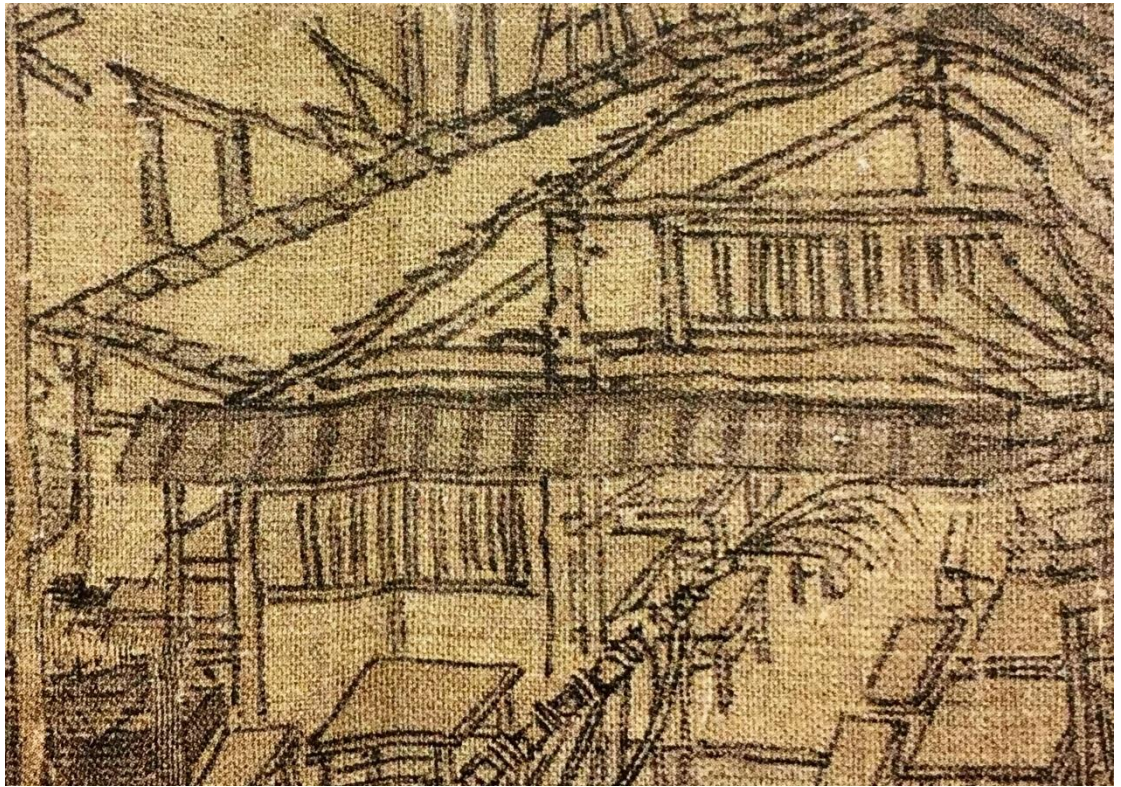


Figure 202

Detail of *Along the River During the Qingming Festival*, the decorative structure



Figure 203

Detail of *Along the River During the Qingming Festival*, the decorative structure

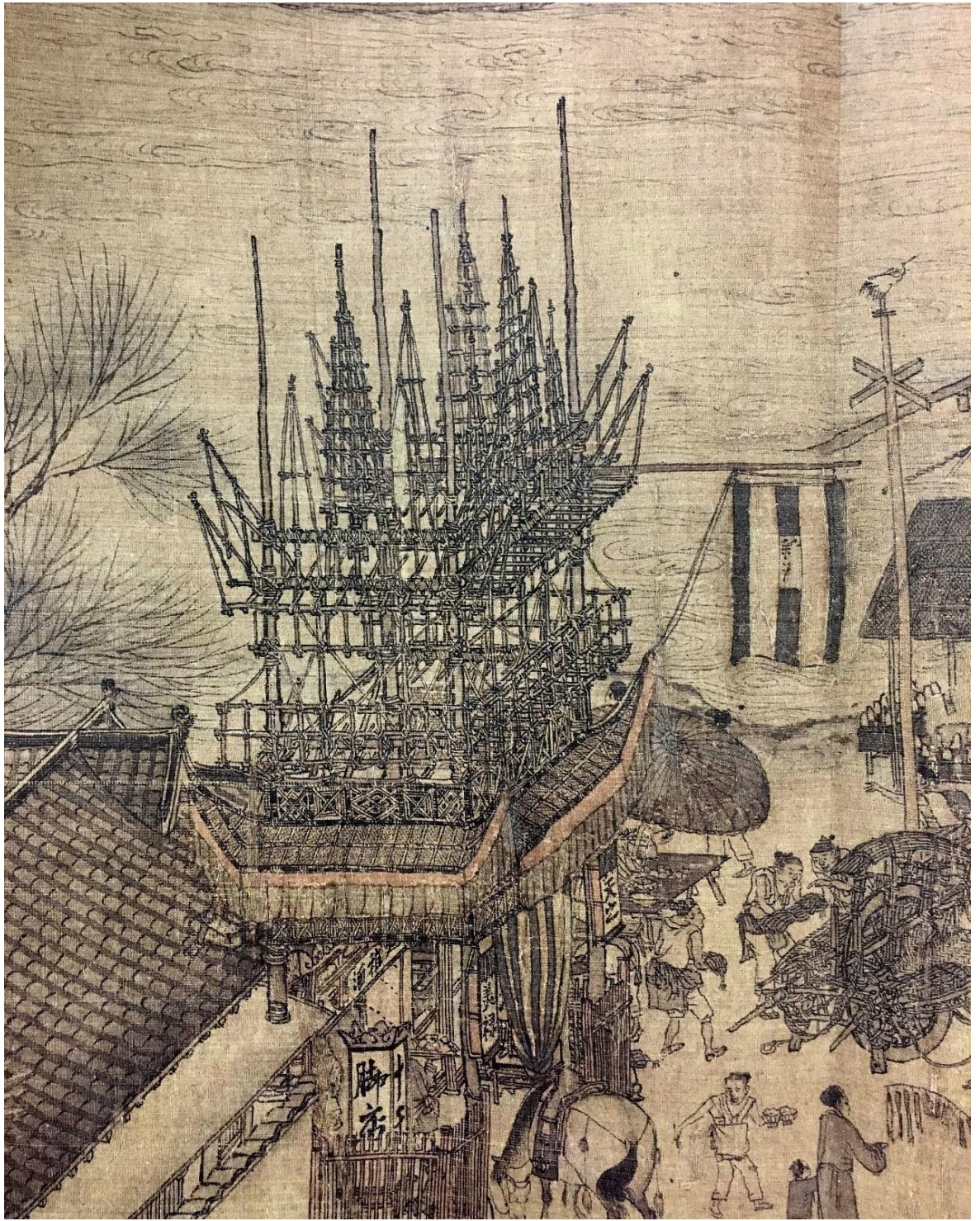


Figure 204

Detail of *Along the River During the Qingming Festival*
the decorative structure of *Shiqian jiaodian*

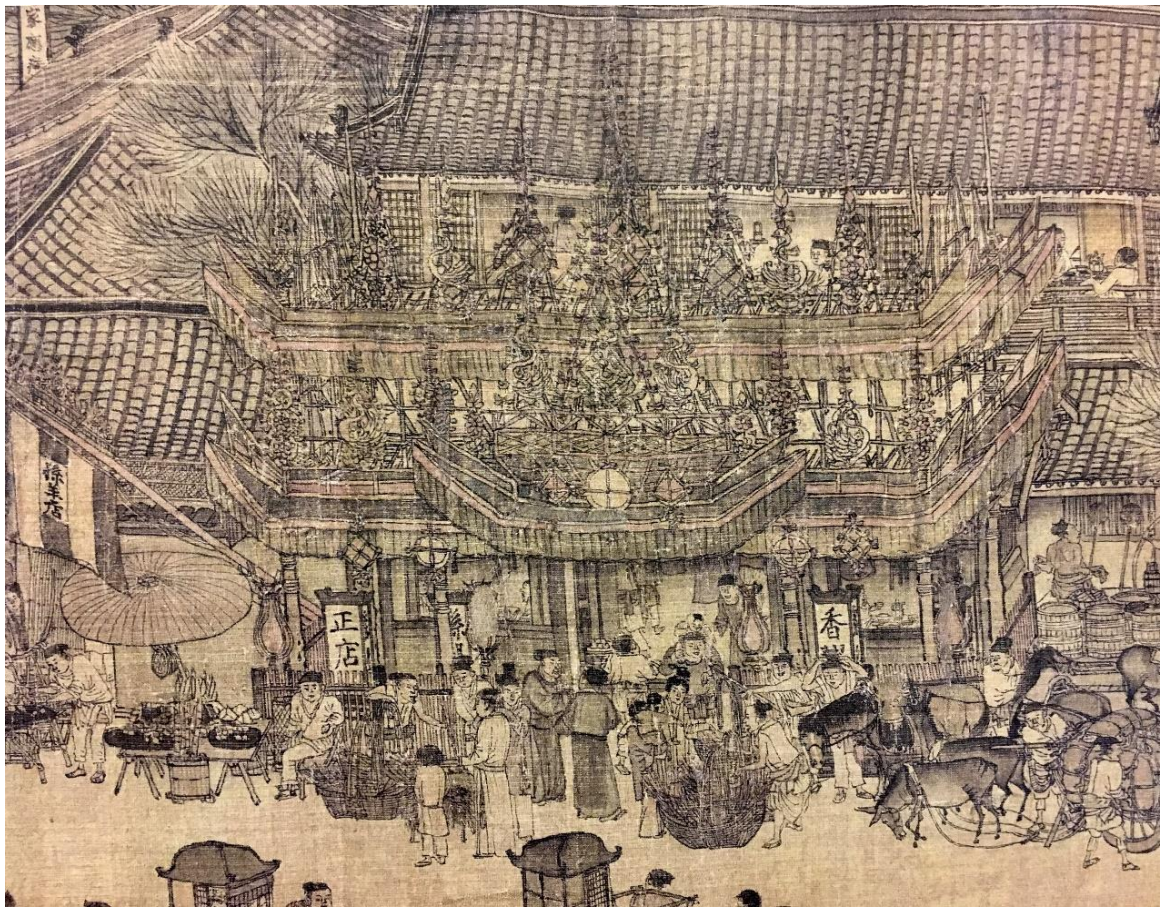


Figure 205

Detail of *Along the River During the Qingming Festival*
the decorative structure of Sunyang zhengdian

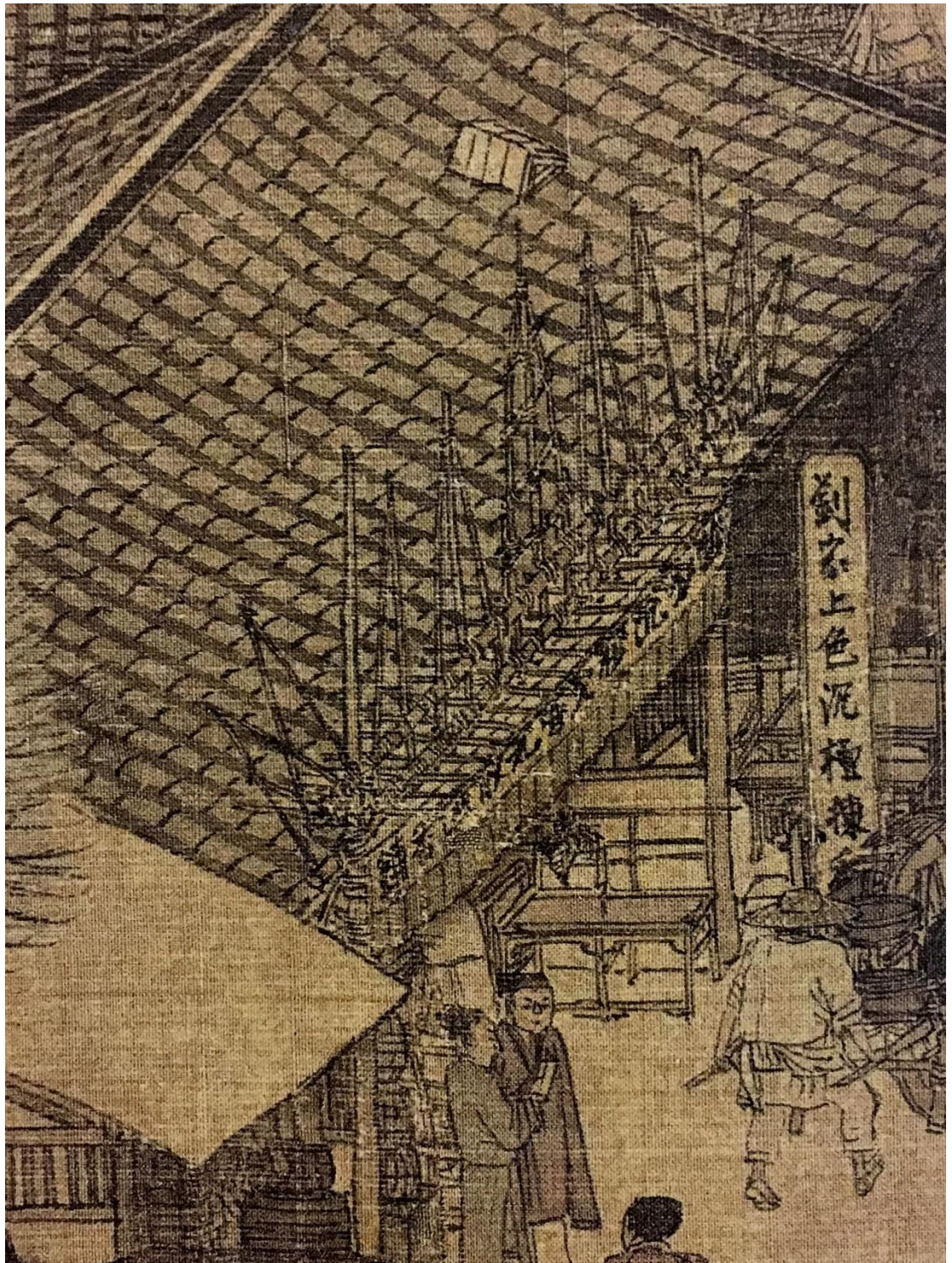


Figure 206

Detail of *Along the River During the Qingming Festival*, the decorative structure

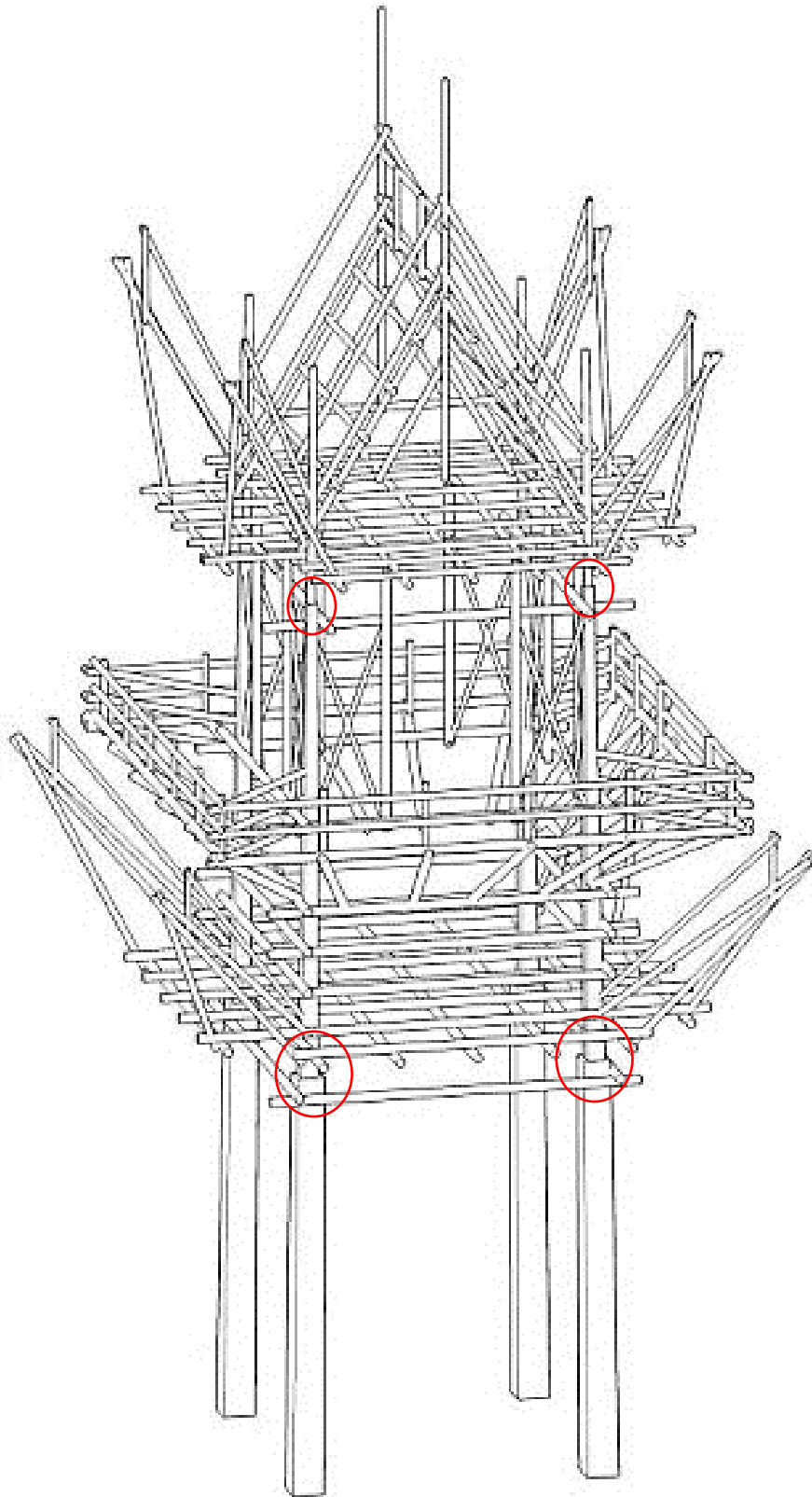


Figure 207
Line drawing of the decorative structure of *The Water Mill*
(Image from *Architect*, 2012:2)

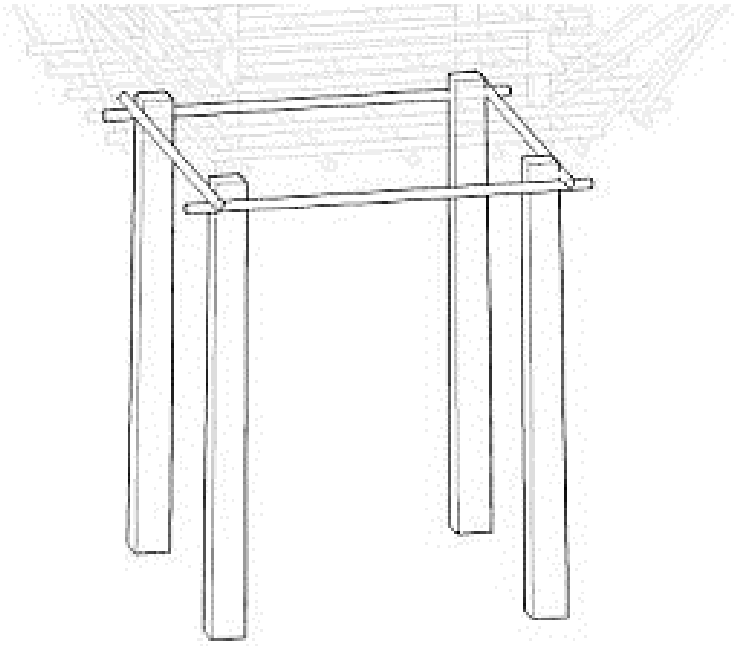


Figure 208
The bottom part of the decorative structure
(Image from *Architect*, 2012:2)

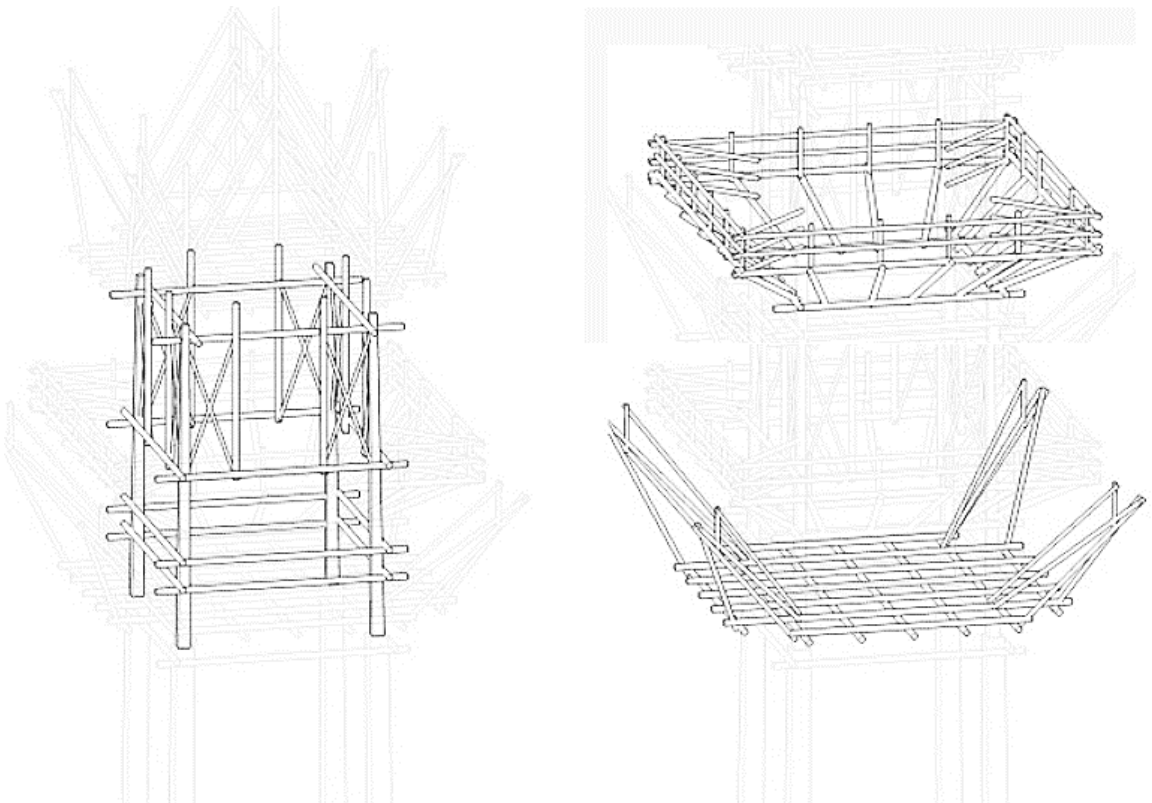


Figure 209
The middle part of the decorative structure
(Image from *Architect*, 2012:2)

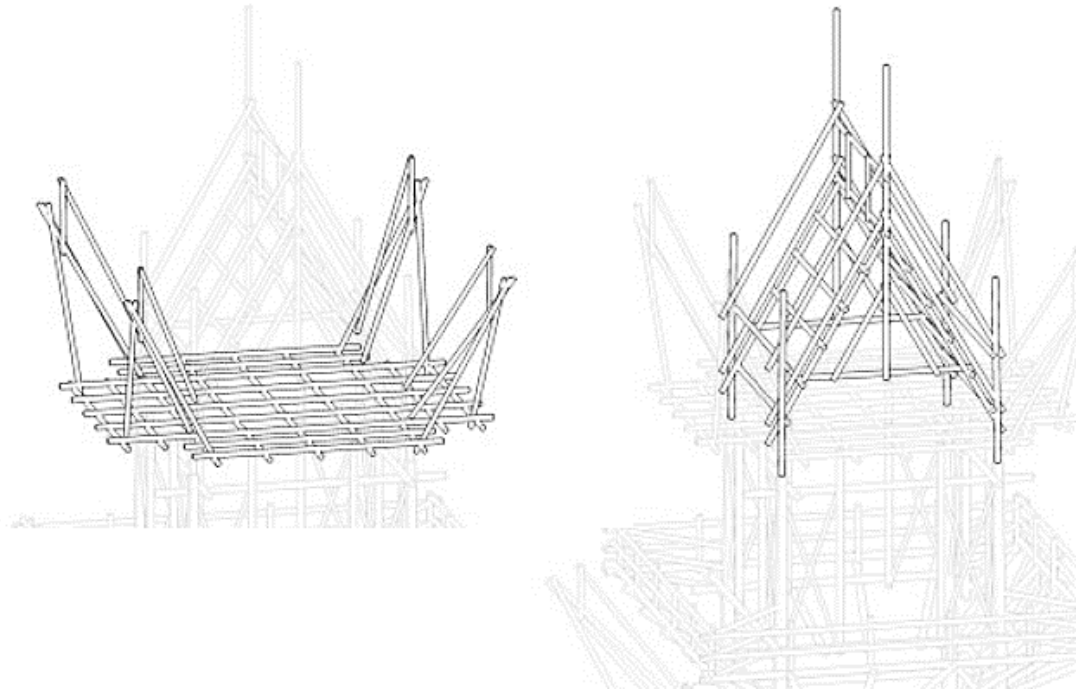


Figure 210
The top part of the decorative structure
(Image from *Architect*, 2012:2)



Figure 211
Detail of *The Water Mill*, the single-eave crossed hip-and-gable roof of the water mill hall



Figure 212

Detail of *The Water Mill in Valley*, the single-eave crossed hip-and-gable roof of the water mill hall



Figure 213

Detail of *Shuidian zhaoliang tu*, the single-eave crossed hip-and-gable roof

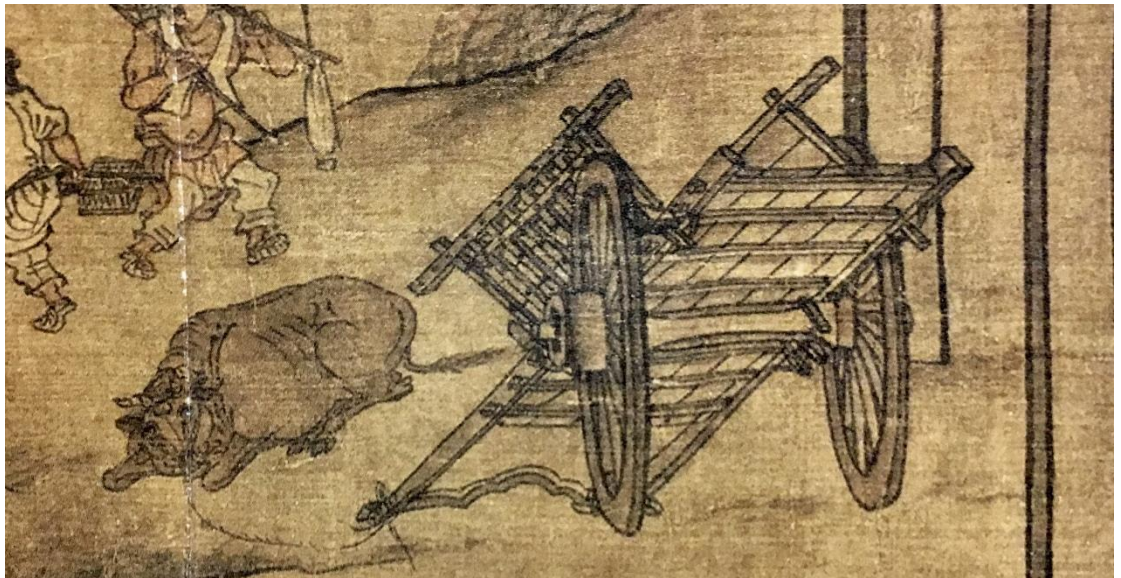


Figure 214
Detail of *The Water Mill*, an empty cart

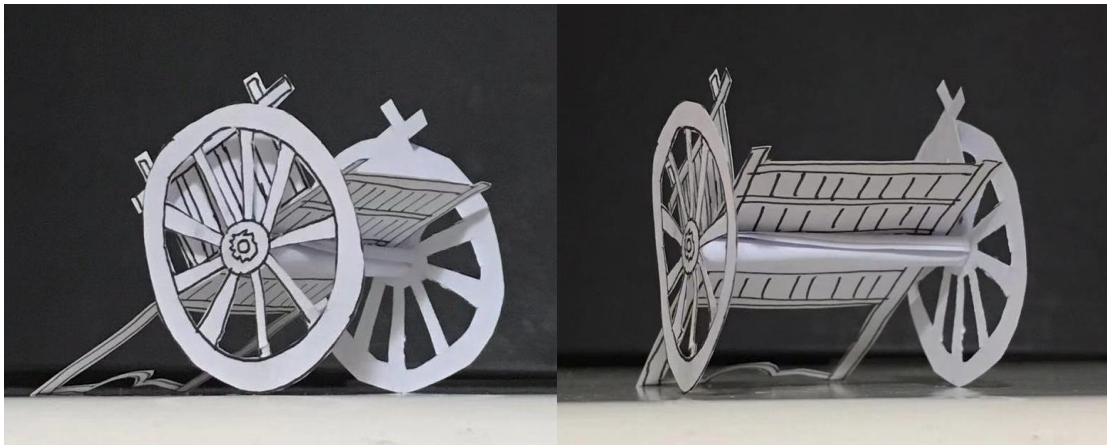


Figure 215
Model of the cart in *The Water Mill*
(Made by BR)

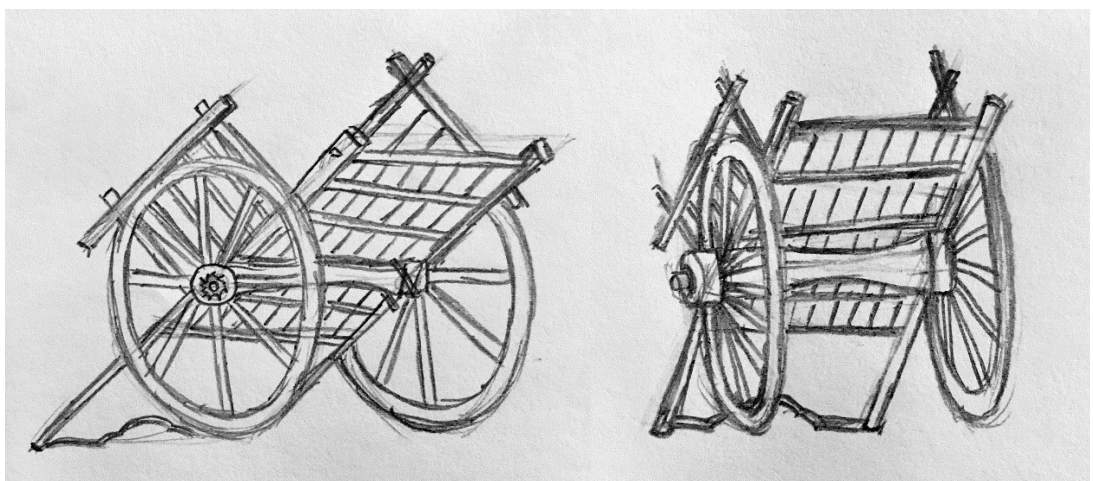


Figure 216
Line drawings of the cart model
(Painted by BR)



Figure 217
The double bracket-arms, Song
The Sanqing Hall of the Yuanmiao Temple, Putian, Fujian province



Figure 218
The caisson ceiling, Liao (984)
The Guanyin Tower of the Dule Temple, Jixian, Tianjin city

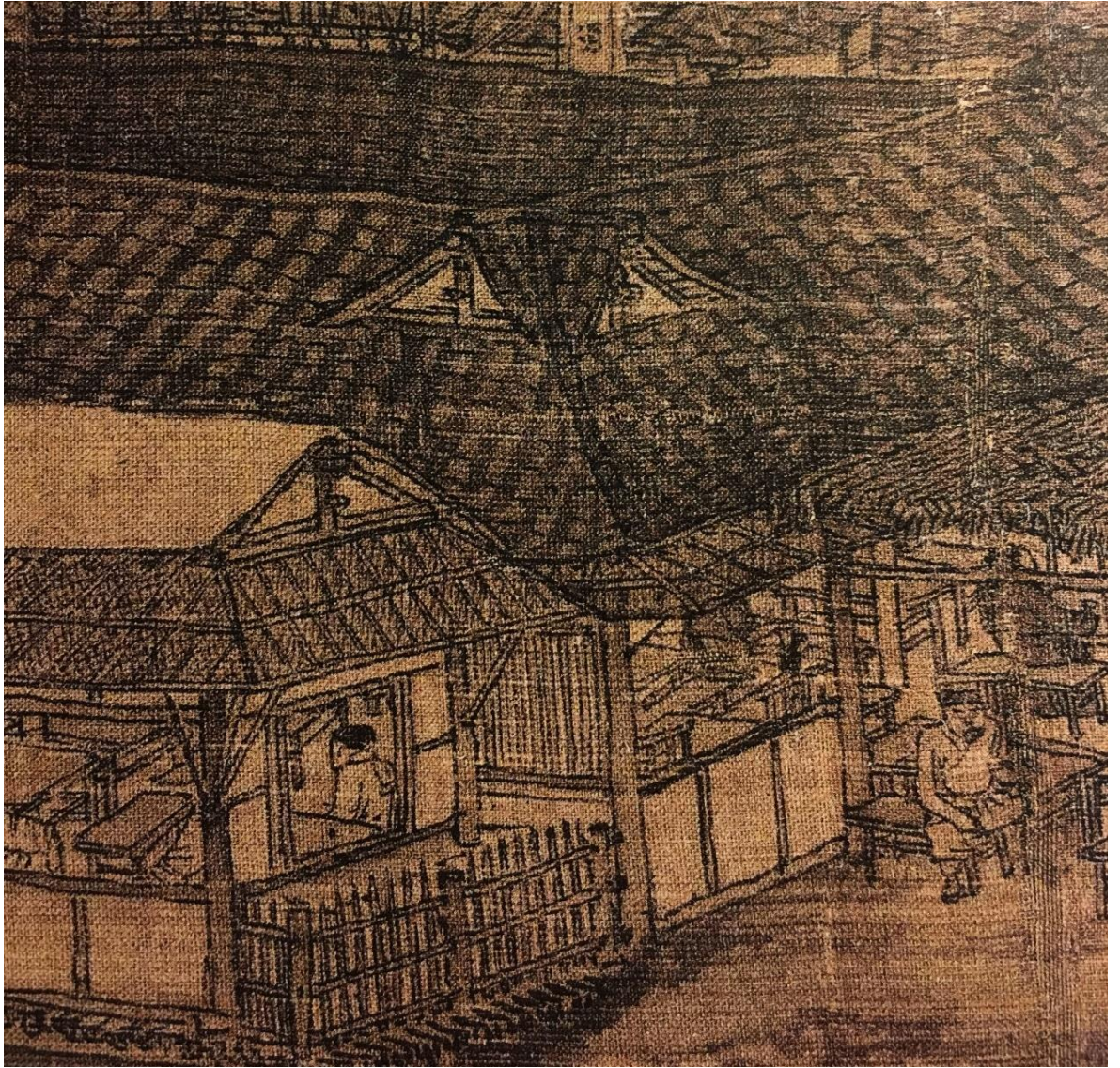


Figure 219

Detail of *Along the River During the Qingming Festival*, the crossed-shaped hip-and-gable roof of a small restaurant



Figure 220

Detail of *Along the River During the Qingming Festival*, the crossed-shaped hip-and-gable roof of the *Shiqian jiaodian*



Figure 221

Detail of *Along the River During the Qingming Festival*, the crossed-shaped hip-and-gable roof of the *Sunyang zhengdian*



Figure 222

Detail of *Along the River During the Qingming Festival*, the crossed-shaped hip-and-gable roof of a hotel¹

¹ *Wang yuanwai jia* 王員外家: The original meaning of *yuanwai* is officials excluded the normal official system. This title can be bought, therefore, *yuanwai* becomes a respectful name of rich man. *Wang yuanwai jia* was a hotel of a wealthy whose surname was Wang.

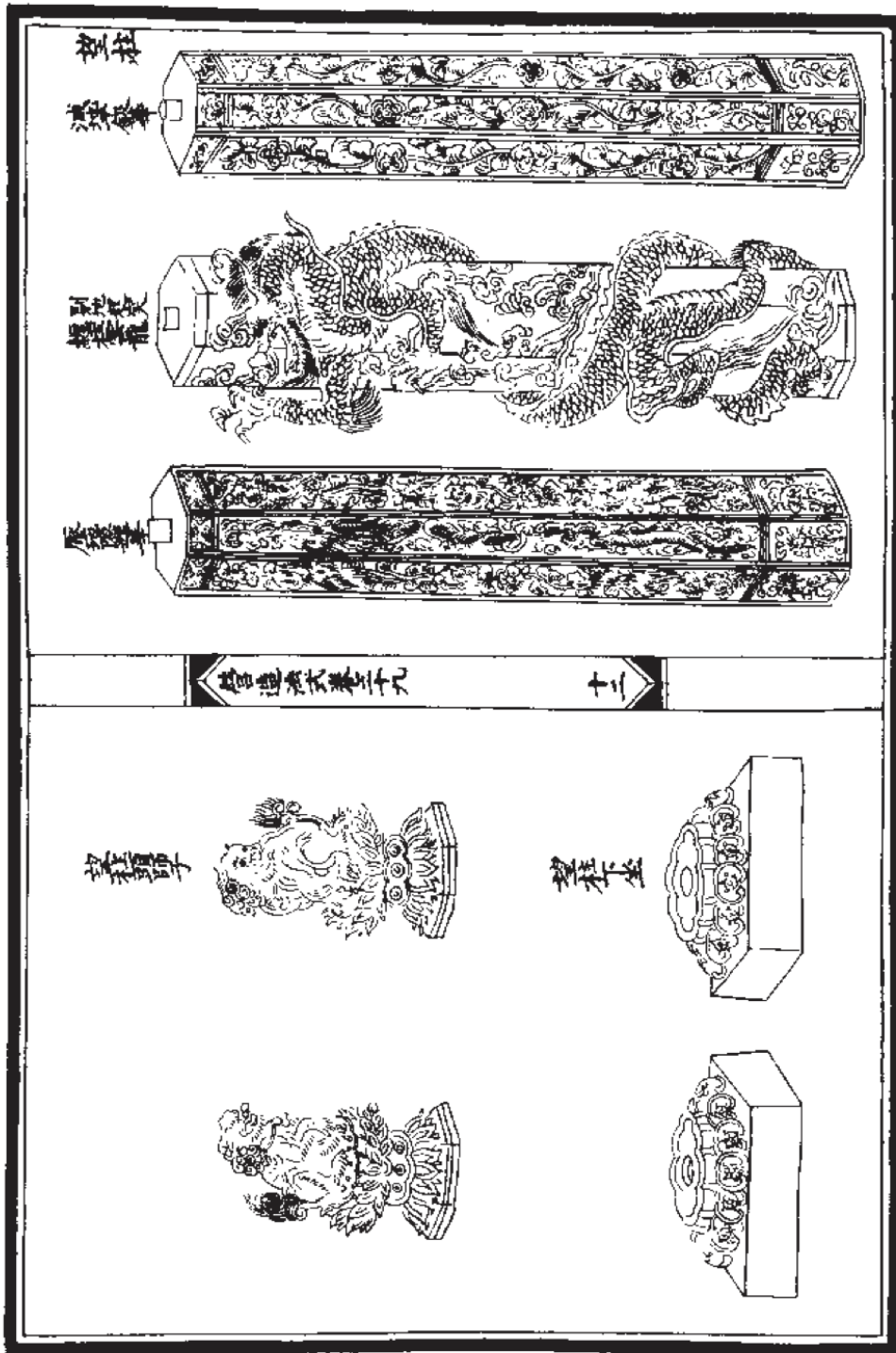


Figure 223
The short pillars
(Image from *Yingzao fashi*, vol 39)



Figure 224
The short pillar of *The Water Mill* and
The *chuang* of the Foguang Temple (877), Wutai county, Shanxi province

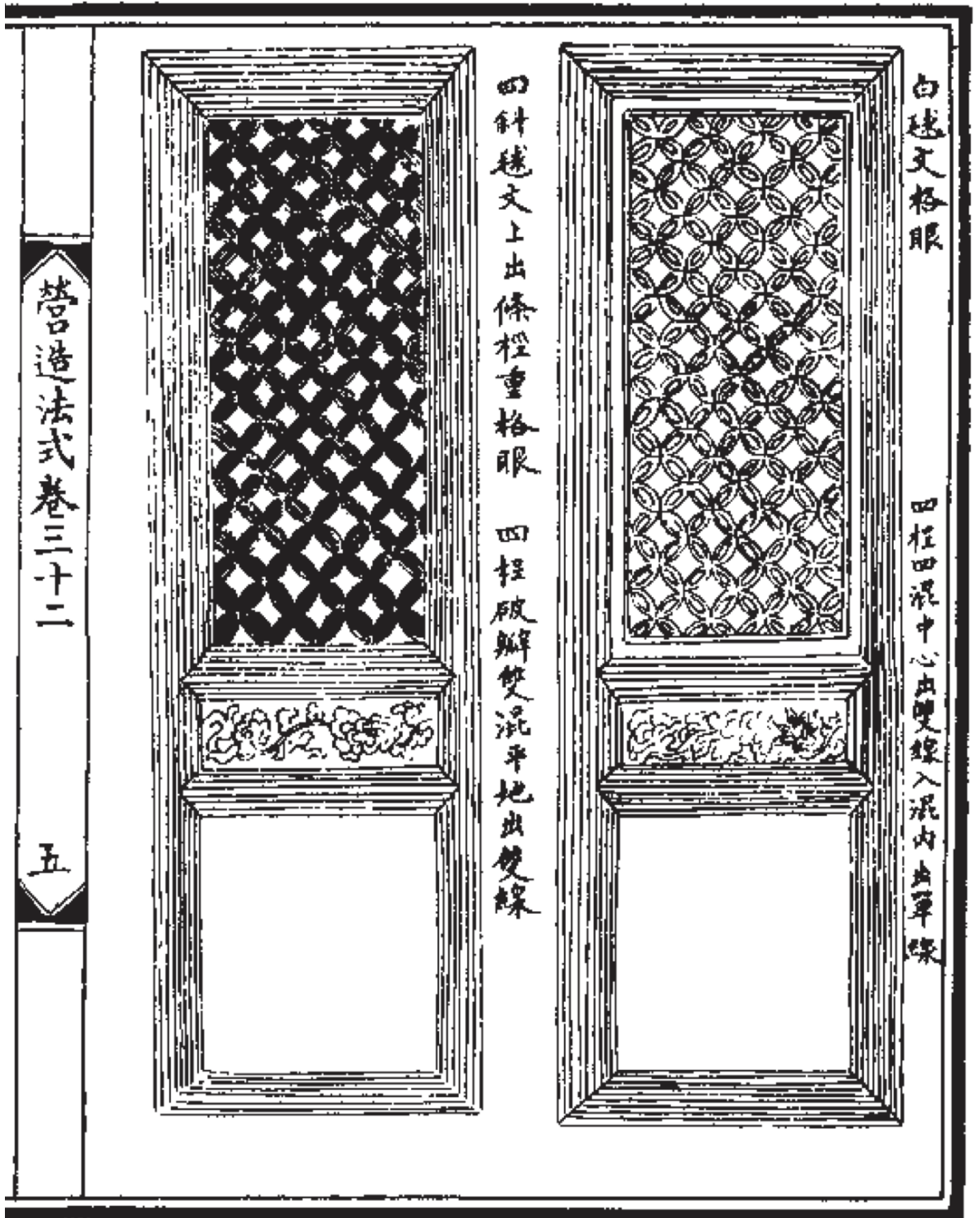


Figure 225
Doors with diamond patterns
(Image from *Yingzao fashi*, vol 32)



Figure 226
Pottery architecture, middle of Eastern Han
Height: 84cm Width: 114cm Length: 130cm
Excavated from No.1 tomb of Yuzhuang, Huaiyang County, Zhoukou, Henan province
(Image from *Jianzhu shishi* vol1, 45)

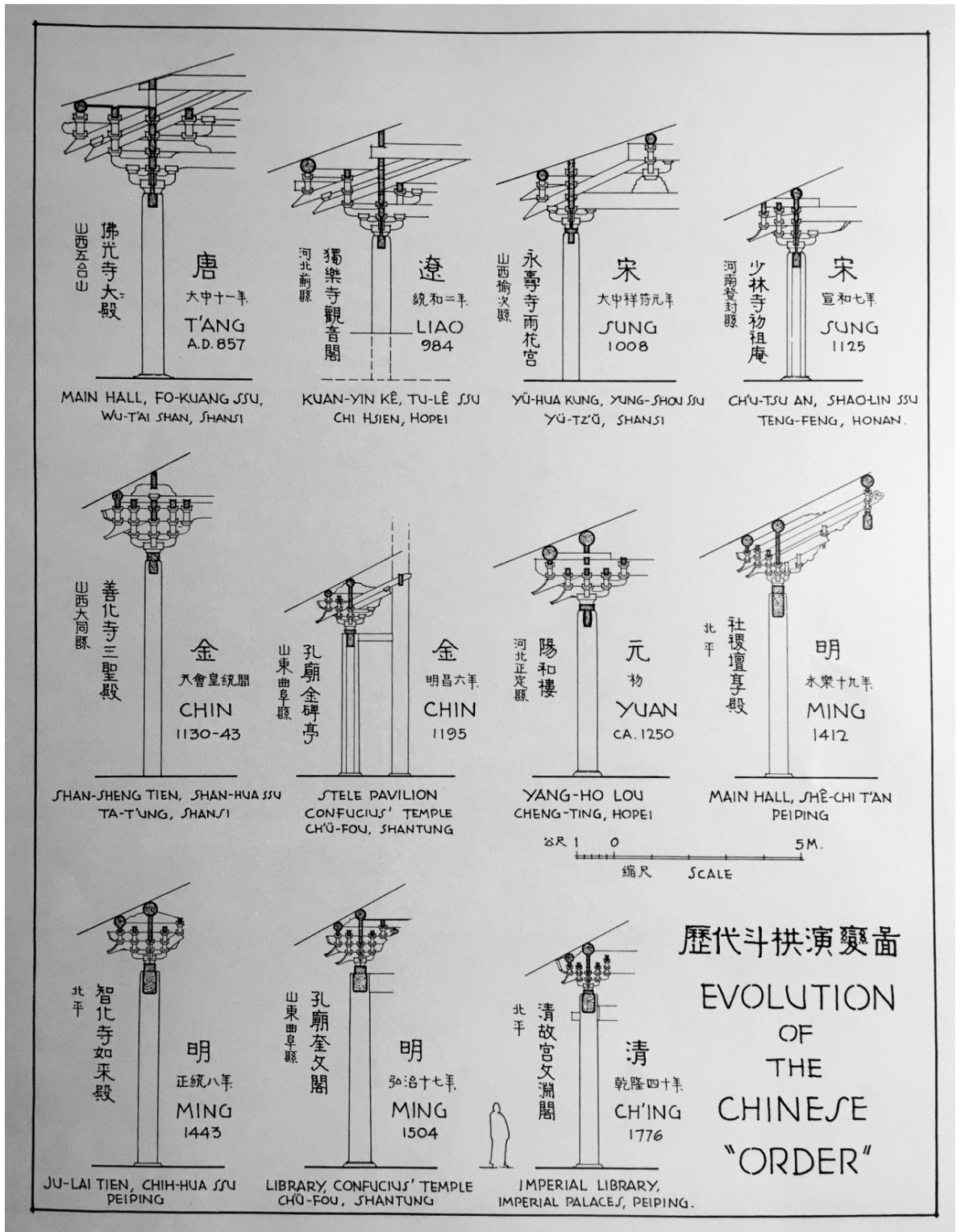


Figure 227
Evolution of the Chinese "order"
(Image from *A pictorial history of Chinese architecture*, 32)

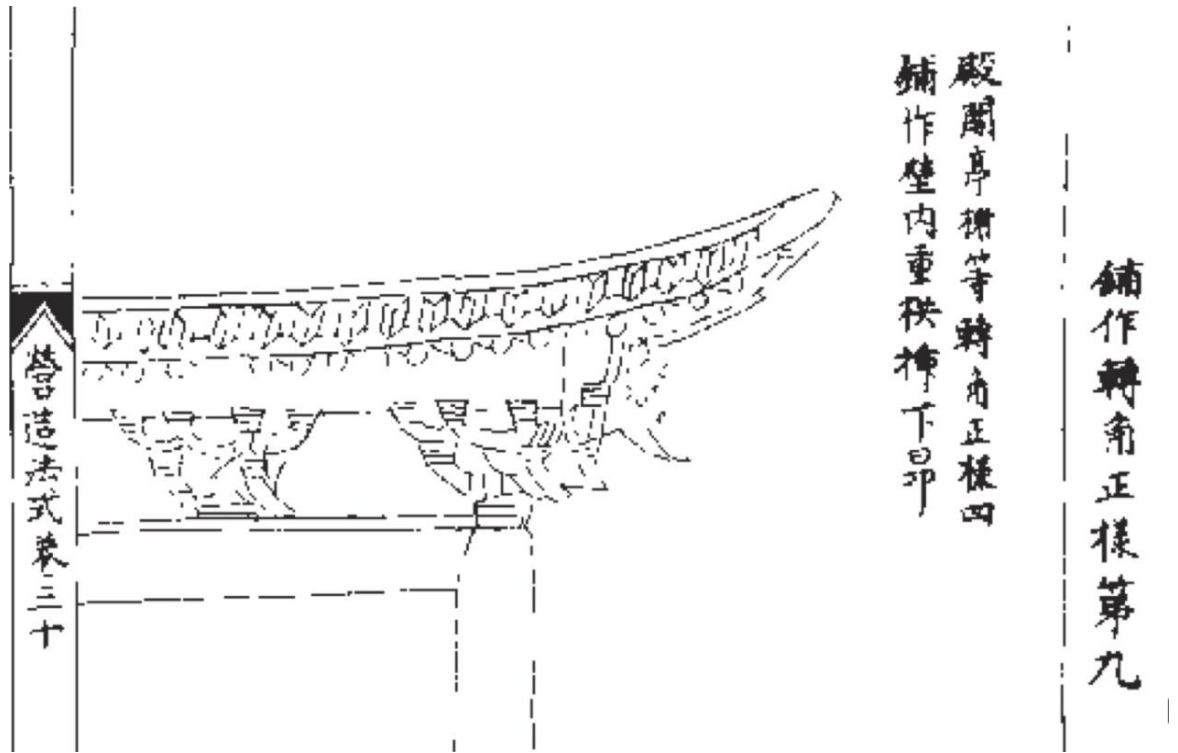


Figure 232

The *yitiao sipuzuo danxia'ang* corner bracket set
(Image from *Yingzao fashi*, vol 30)



Figure 233

The main hall of Chuzu An, in the Shaolin Temple, Dengfeng, Henan province
(Photo by ZX)

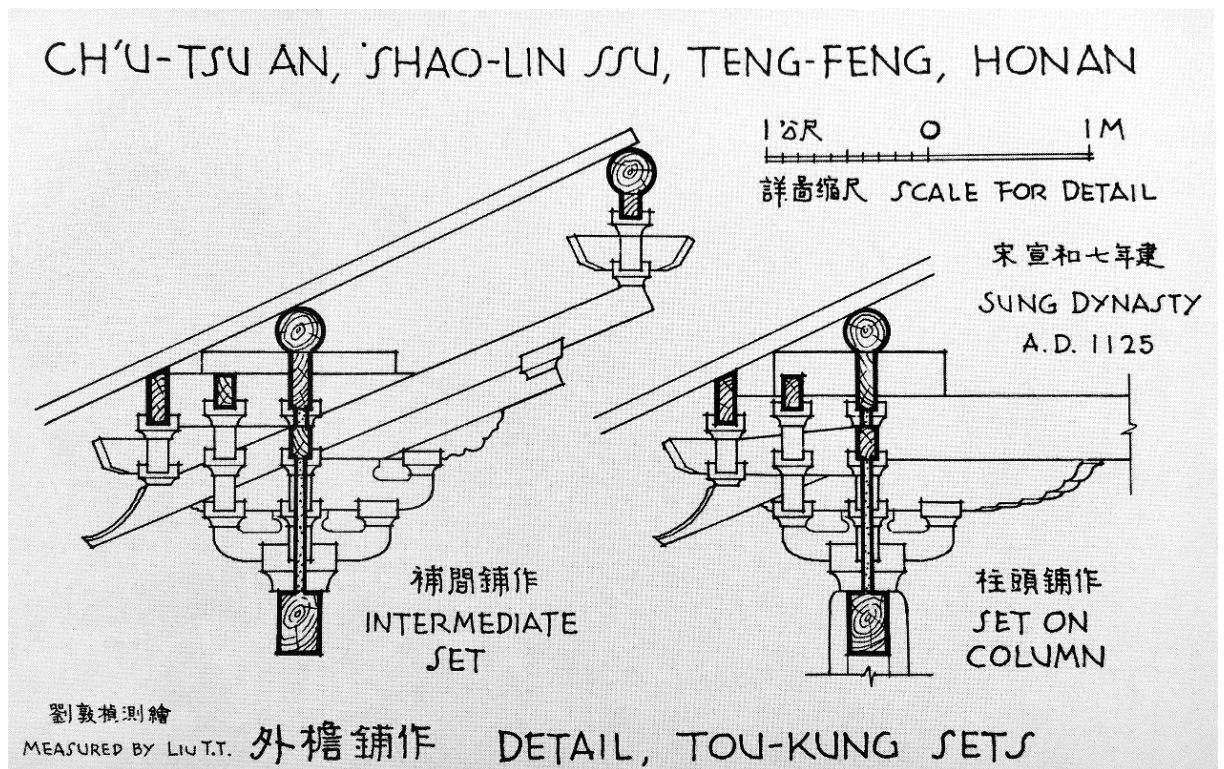


Figure 234
 The line drawing of the bracket set of Chuzu An
 (Image from *A pictorial history of Chinese architecture*, 89)



Figure 235
 Detail of *The Water Mill*, the *ang* and *shuatou* of the water mill hall



Figure 236
The bracket sets of Chuzu An
(Photo by ZX)



Figure 237
The bracket sets of Chuzu An
(Photo by ZX)

歷代耍頭(梁頭)演變圖

EVOLUTION OF THE SHUA-T'OU (HEAD OF THE BEAM)

公分 10 0 50 100 cm.

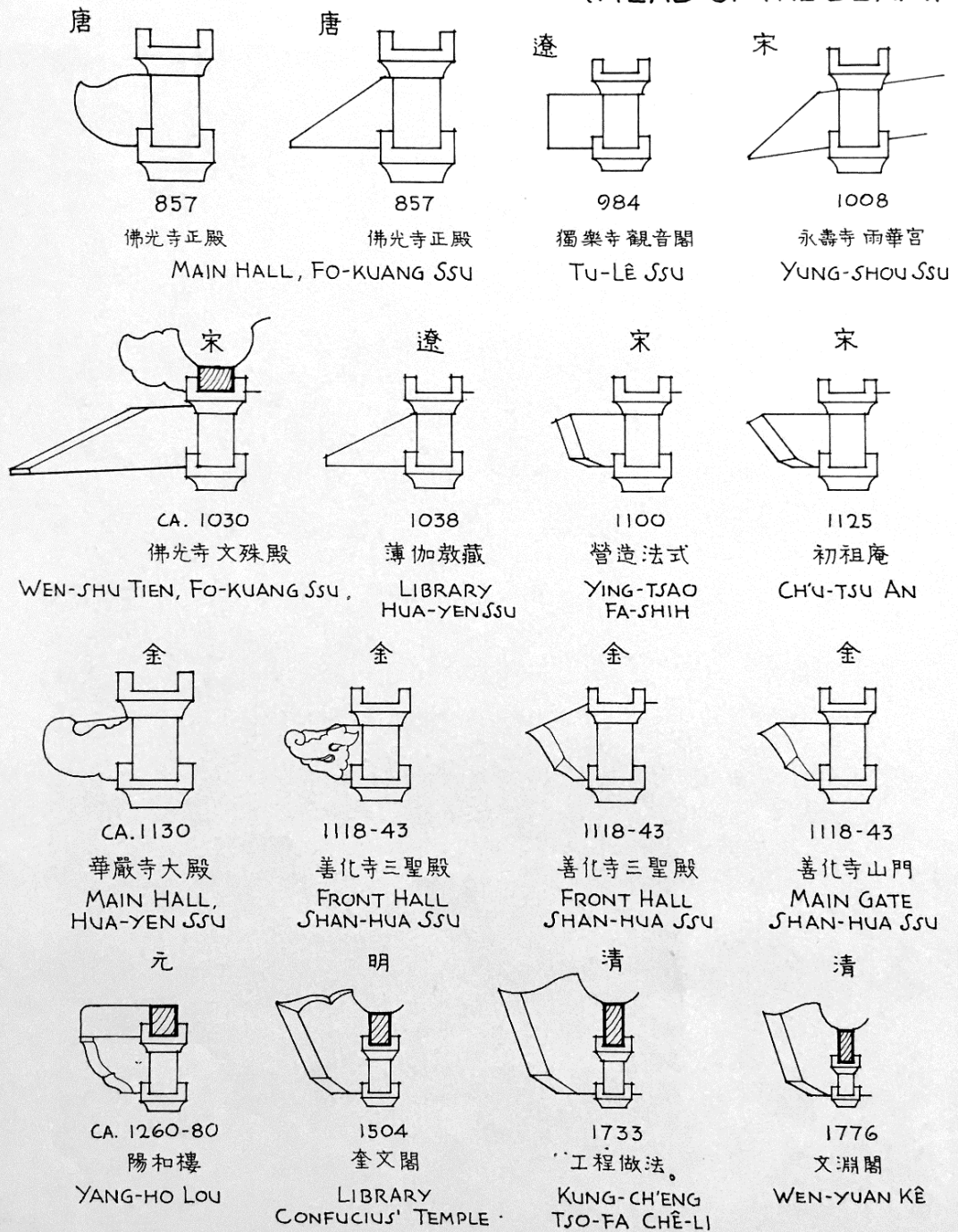


Figure 238

Evolution of the *shuatou* (head of the beam)

(Image from *A pictorial history of Chinese architecture*, 84)

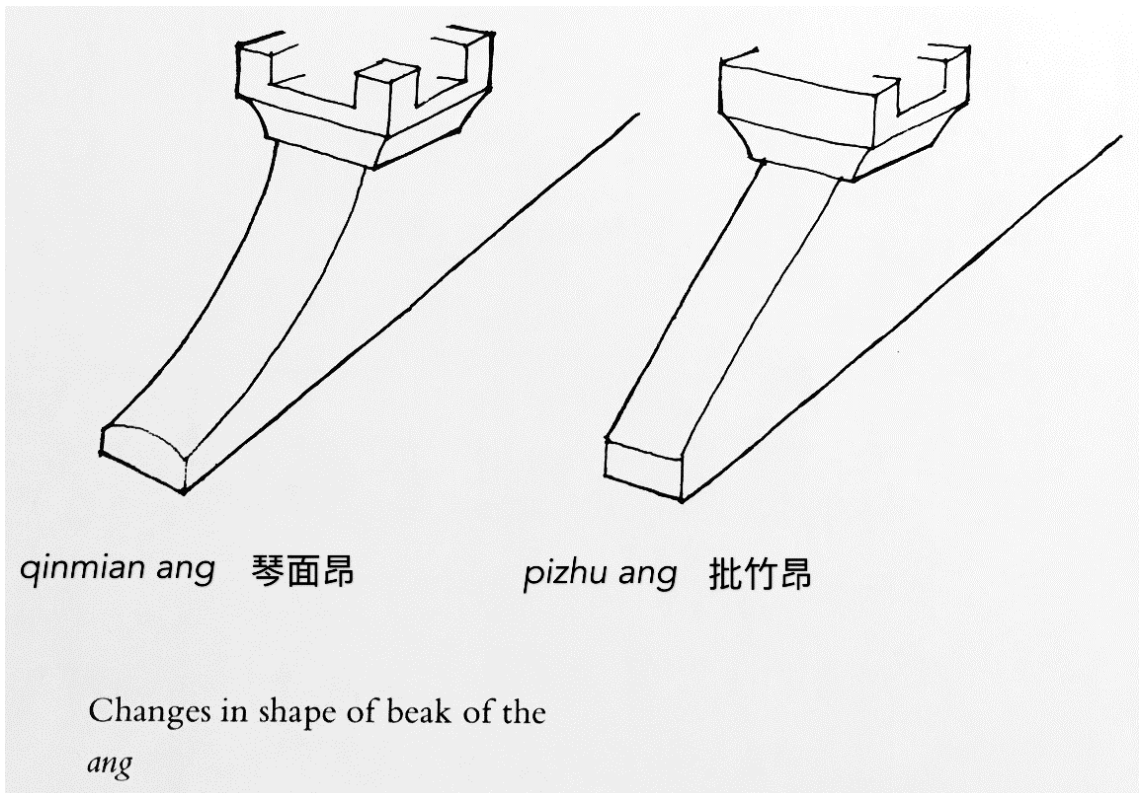


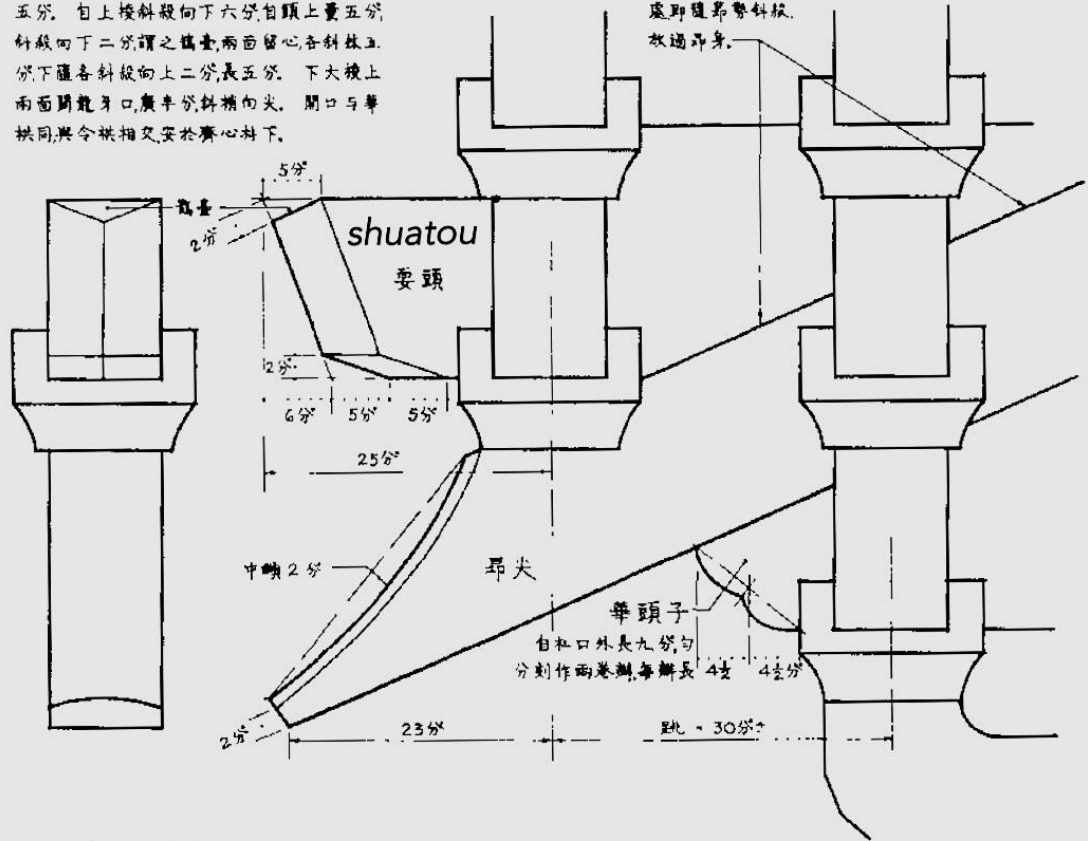
Figure 239
Changes in shape of beak of the *ang*
(Image from *A pictorial history of Chinese architecture*, 83)

大木作制度圖樣四

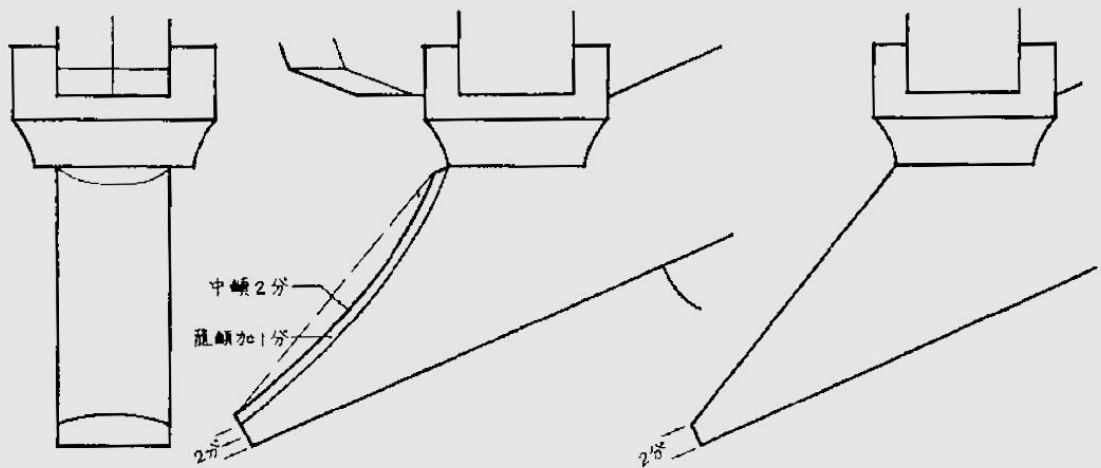
下昂尖卷殺之制 造耍頭之制 (註：龍牙口木見於實例，位置不詳。)

造耍頭之制 用足材自料心出長二十五分，自上橫斜殺向下六分自頭上量五分，斜殺向下二分，謂之鴛臺，兩面留心，各斜殺五分，下隨各斜殺向上二分，長五分。下大橫上兩面開龍牙口，廣半分，斜補向尖。開口與華拱同，與令拱相交，安於齊心斜下。

如上下有礙昂處，即隨昂勢斜殺，放過昂身。



造下昂之制 自上一材垂頭向下，從料底心下取直，其長二十三分，其昂身上微屋內。自料外斜殺向下，留二分，昂面中曠二分，令曠勢圓和。



亦有於昂面上龍頭加一分，就殺至兩梭者，謂之

琴面昂
qinmian ang

亦有自料外斜殺至尖者，其昂面平直謂之

批竹昂
pizhu ang

Figure 240

Different shapes of beak of the ang
(Image from *Yingzao fashi*, vol 28)

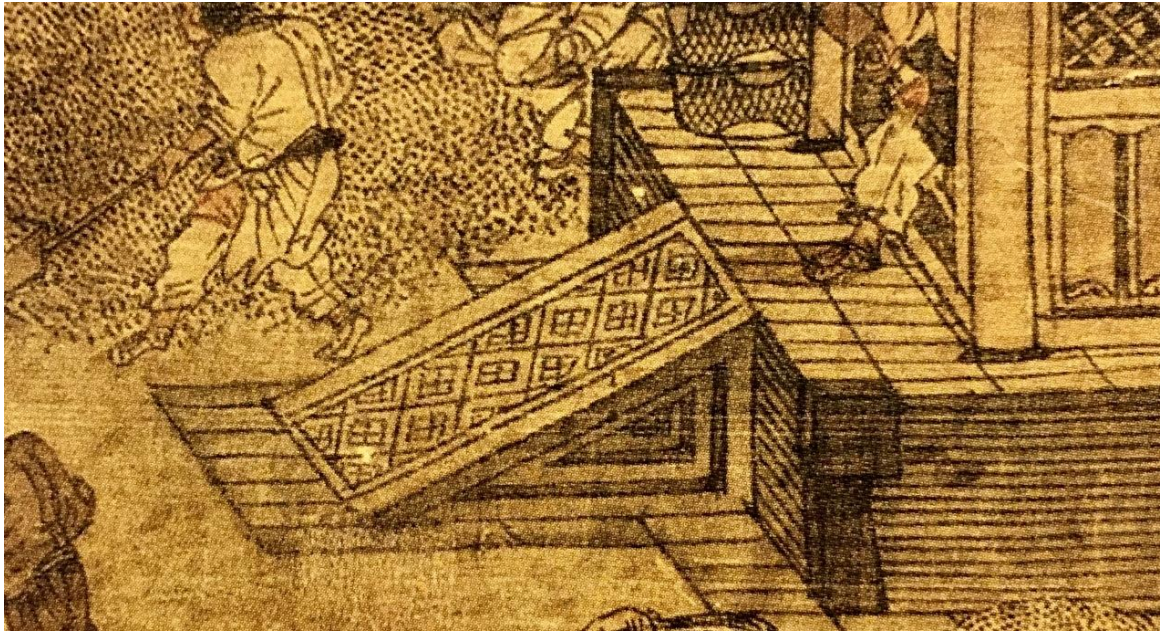


Figure 241
Detail of *The Water Mill*, the stairs with *xiangyan*



Figure 242
Detail of *The Water Mill*, the stairs with *xiangyan*

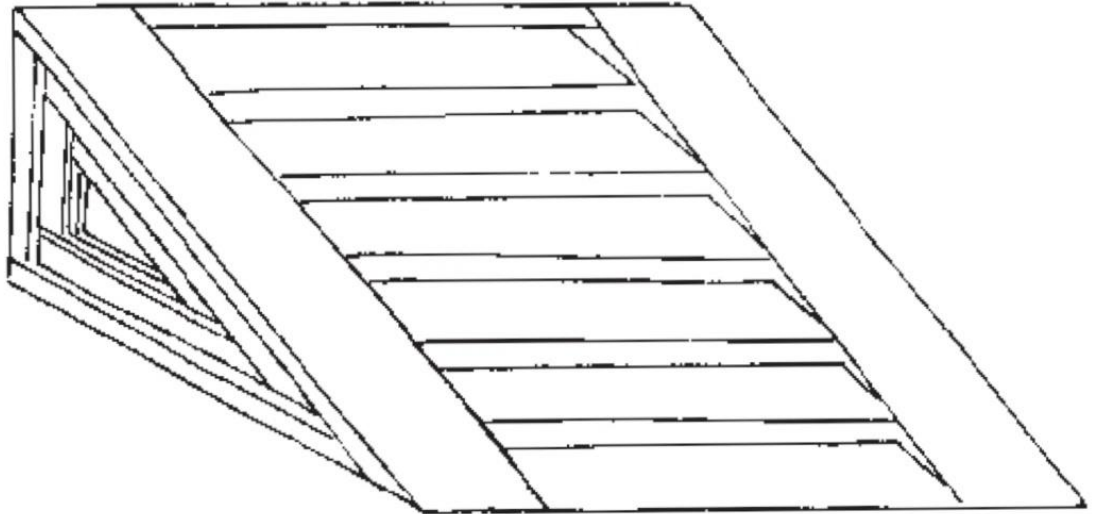


Figure 243
A line drawing of steps and *xiangyan*
(Image from *Yingzao fashi*, vol 29)

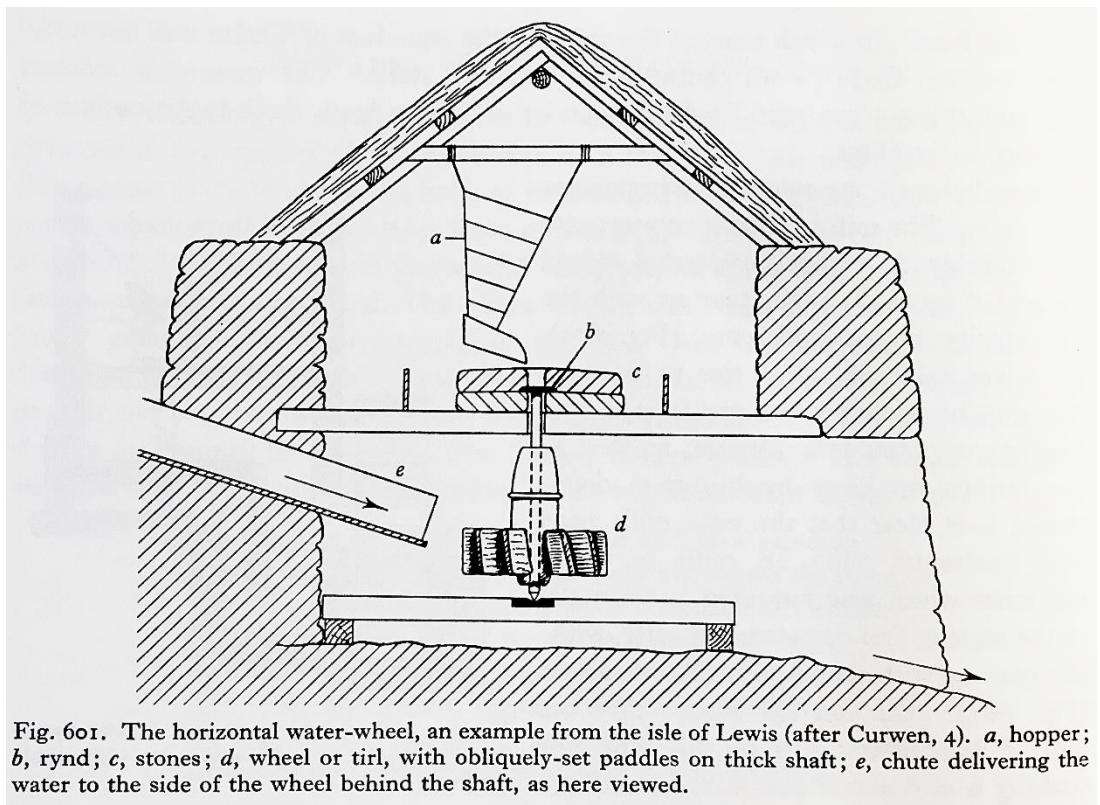


Fig. 601. The horizontal water-wheel, an example from the isle of Lewis (after Curwen, 4). *a*, hopper; *b*, rynd; *c*, stones; *d*, wheel or tirl, with obliquely-set paddles on thick shaft; *e*, chute delivering the water to the side of the wheel behind the shaft, as here viewed.

Figure 244
Image from *Science and Civilisation in China*, vol 4, part 2, 368

木 龍



Figure 245
The long
(Image from *Tiangong kaiwu*, 60)



Figure 246
The chong
(Image from *Tiangong kaiwu*, 64)

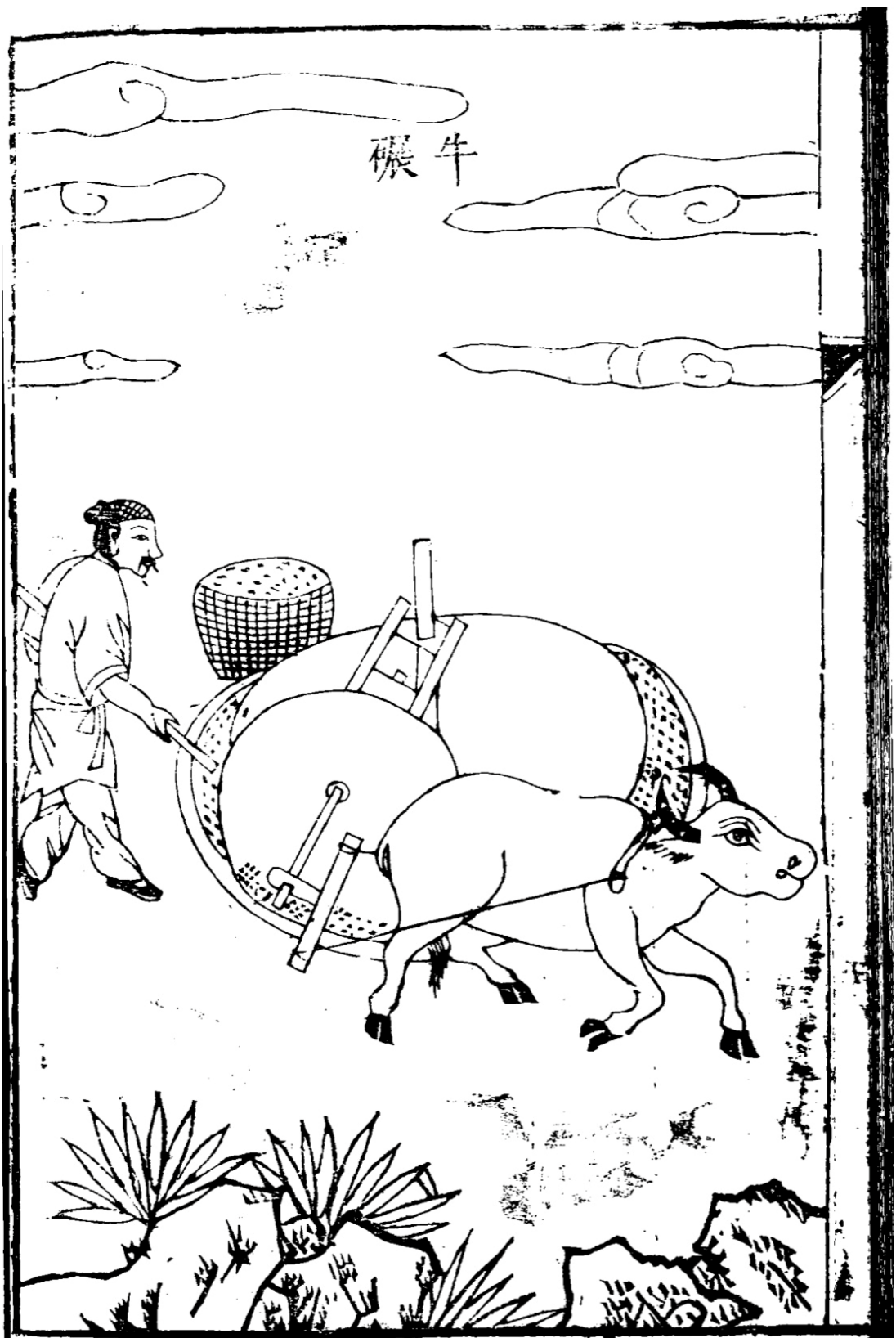


Figure 247
The *nian*
(Image from *Tiangong kaiwu*, 59)

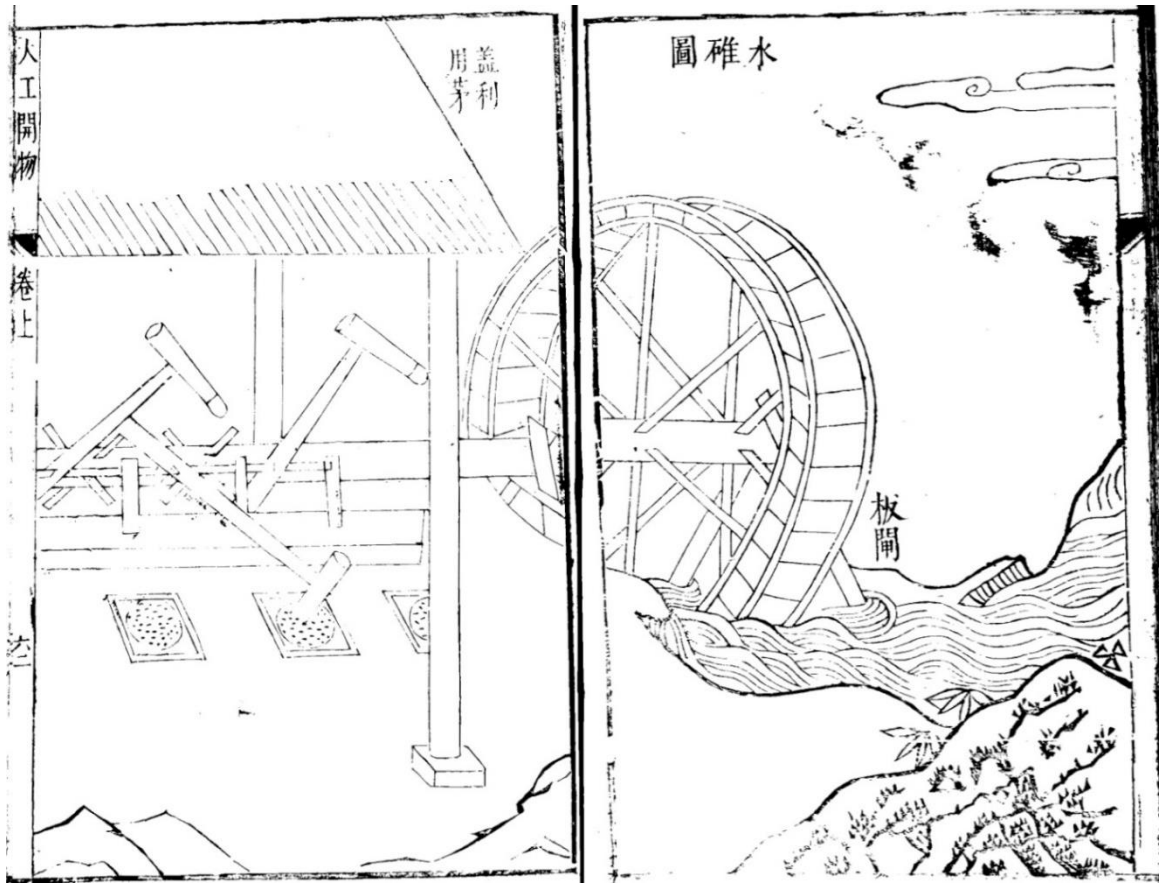


Figure 248
The multi water-driven trip-hammer structure
(Image from *Tiangong kaiwu*, 62)

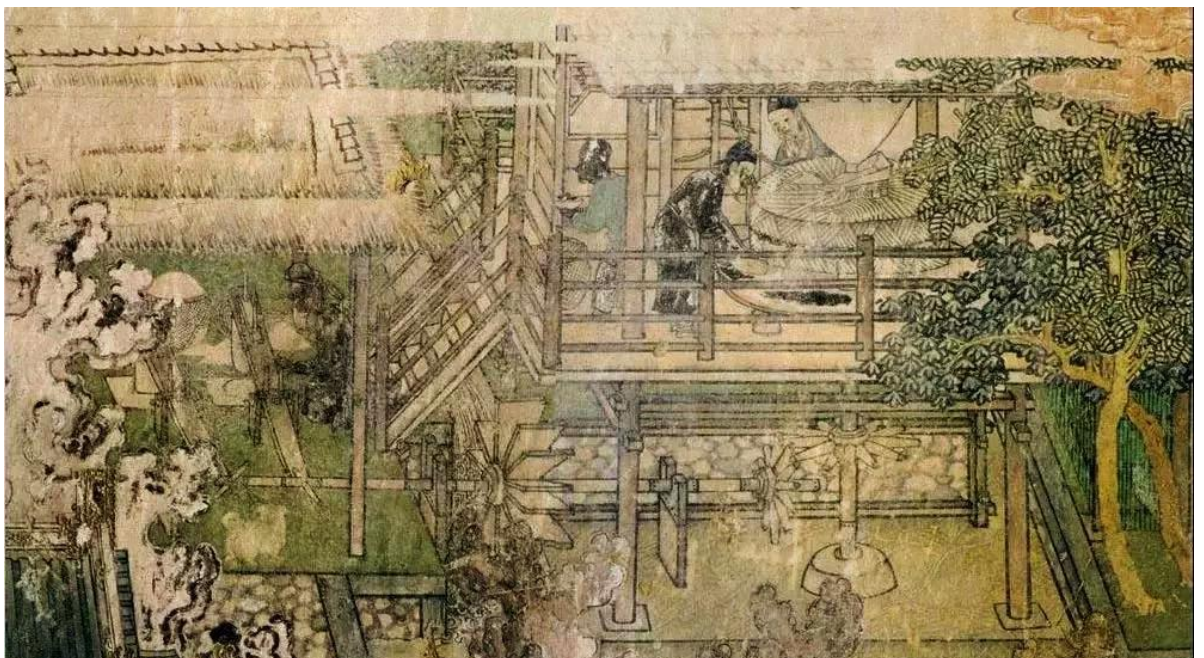


Figure 249
The Water Trip-Hammer and The Water Mill (same as the Figure 8)

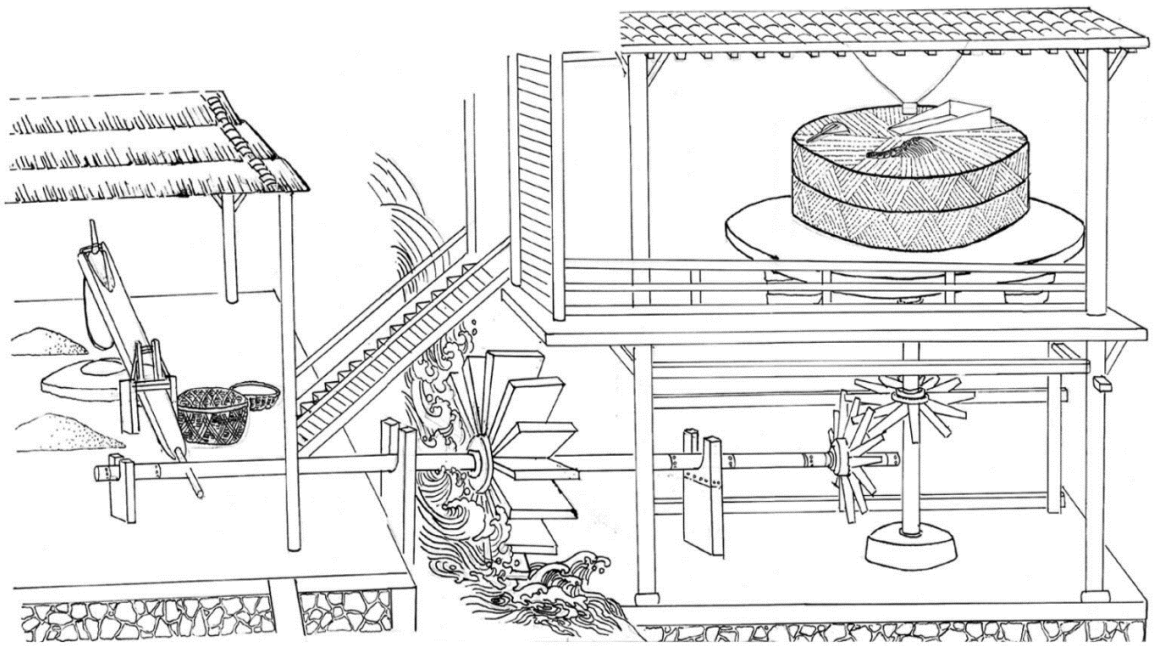


Figure 250

Line drawing of *The Water Trip-Hammer and The Water Mill*
(Image from *Science, Technology and Dialectics*, 2007:3)

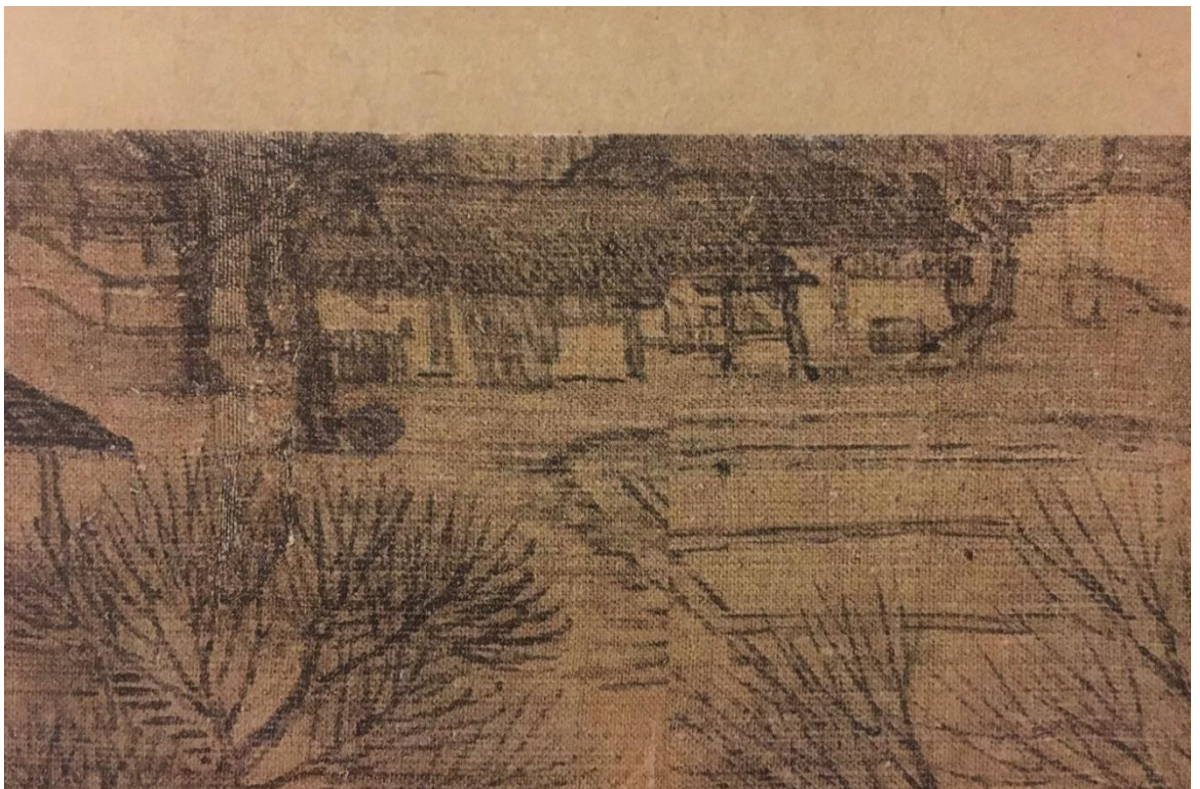


Figure 251

Detail of *Along the River During the Qingming Festival*, the stone rollers

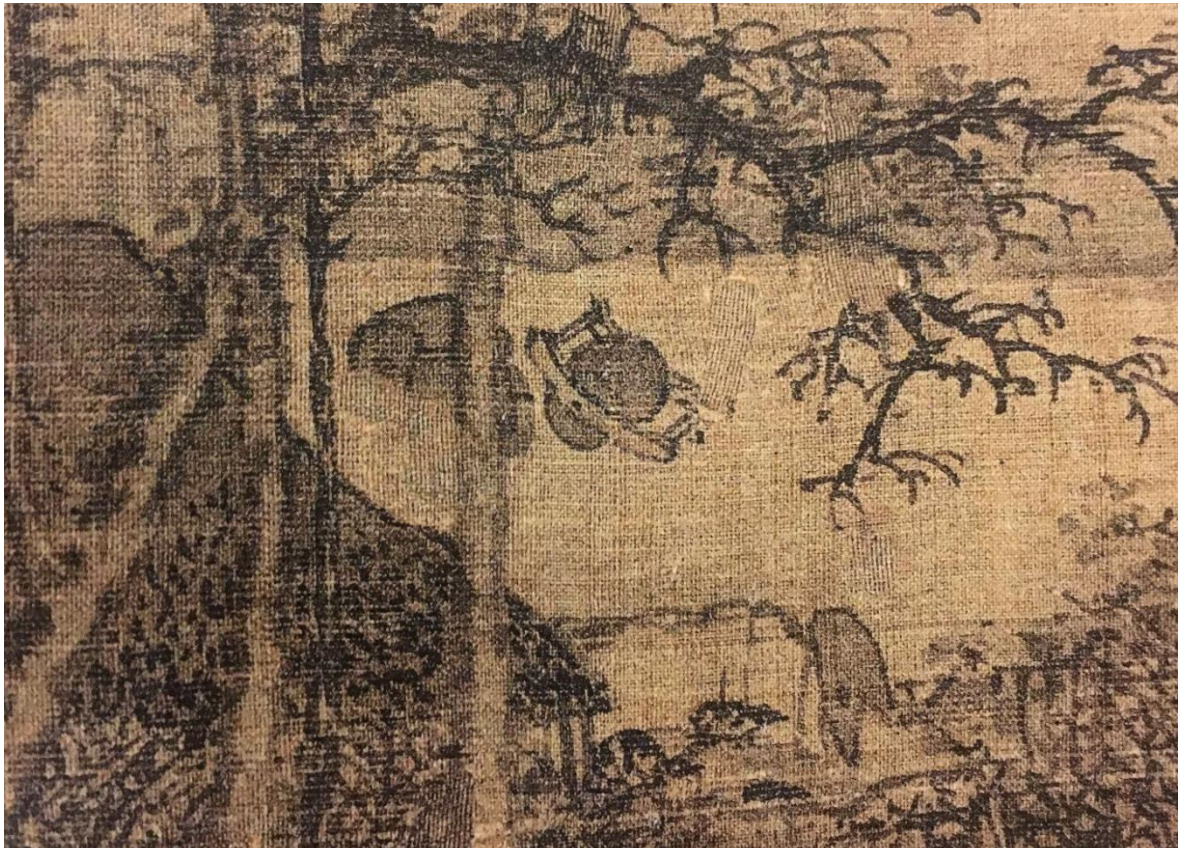


Figure 252
Detail of *Along the River During the Qingming Festival*, the stone rollers



Figure 253
Detail of *Along the River During the Qingming Festival*, the stone roller and the cattle



Figure 254
Detail of *The Water Mill in Valley*, the multiple turbine wheels and wheel gears

其
文
學

卷
下
七

磨水輪卧

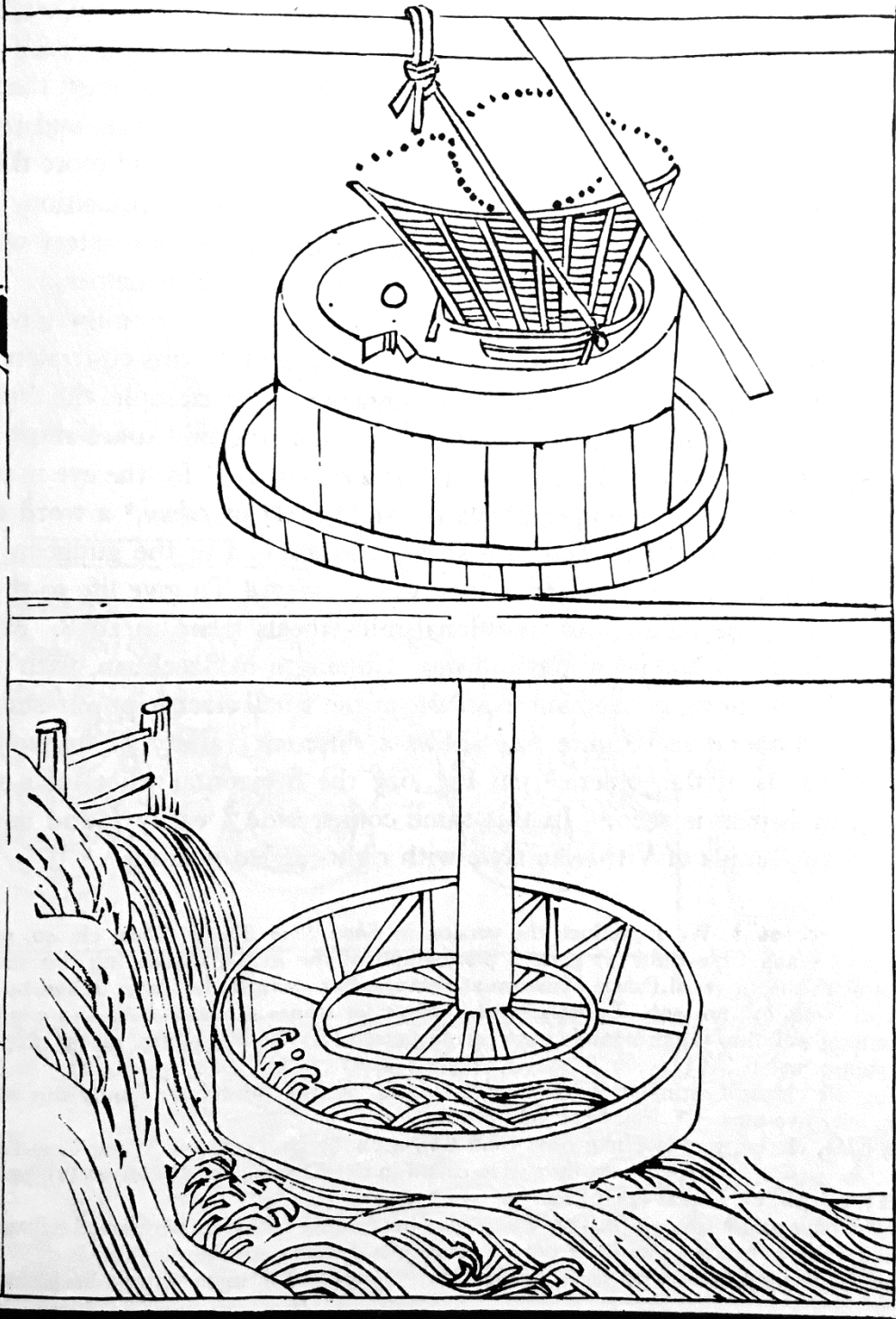


Fig. 621. The most characteristic Chinese form of water-mill, a millstone driven by a horizontal water-wheel (*wo lun shui mo*); from *Nung Shu* (+ 1313), ch. 19, p. 4a.

Figure 255

The horizontal water wheel of *Nongshu*

(Image from *Science and Civilisation in China*, vol 4, part 2, 397)

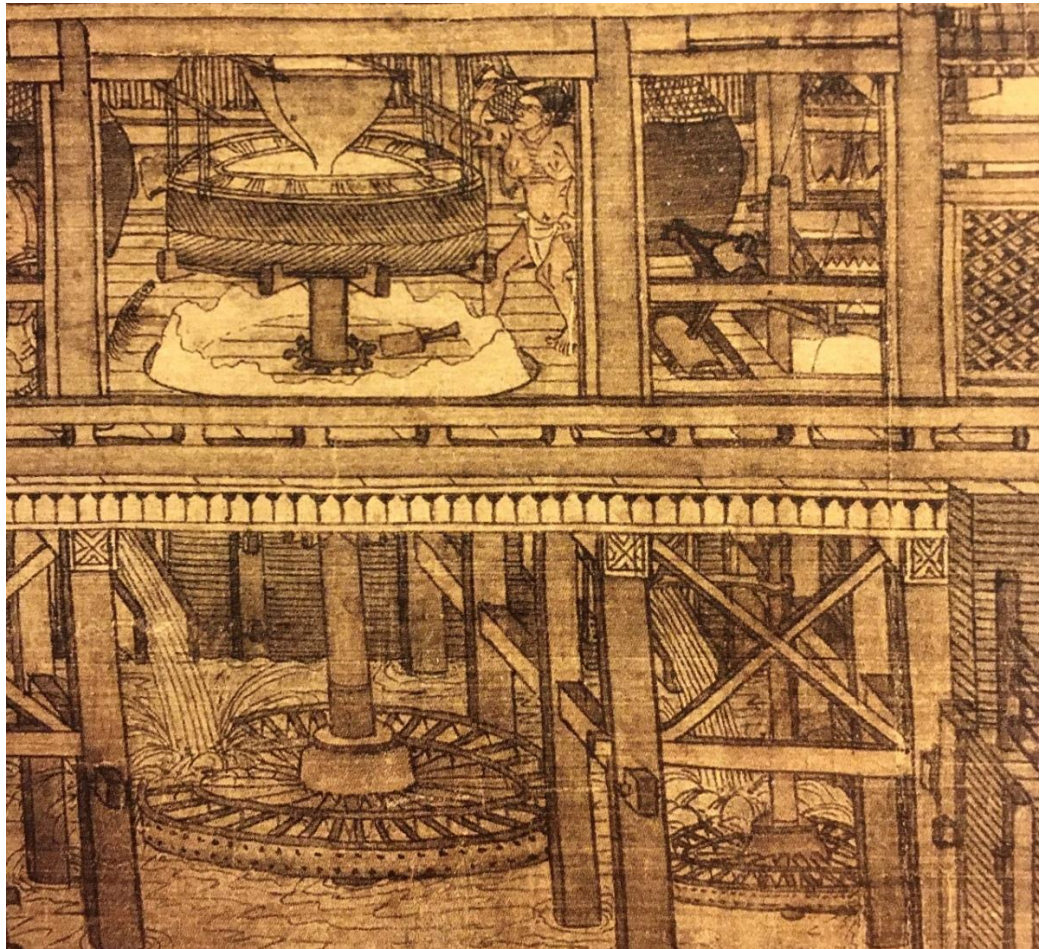


Figure 256

Detail of *The Water Mill*, the horizontal water wheels

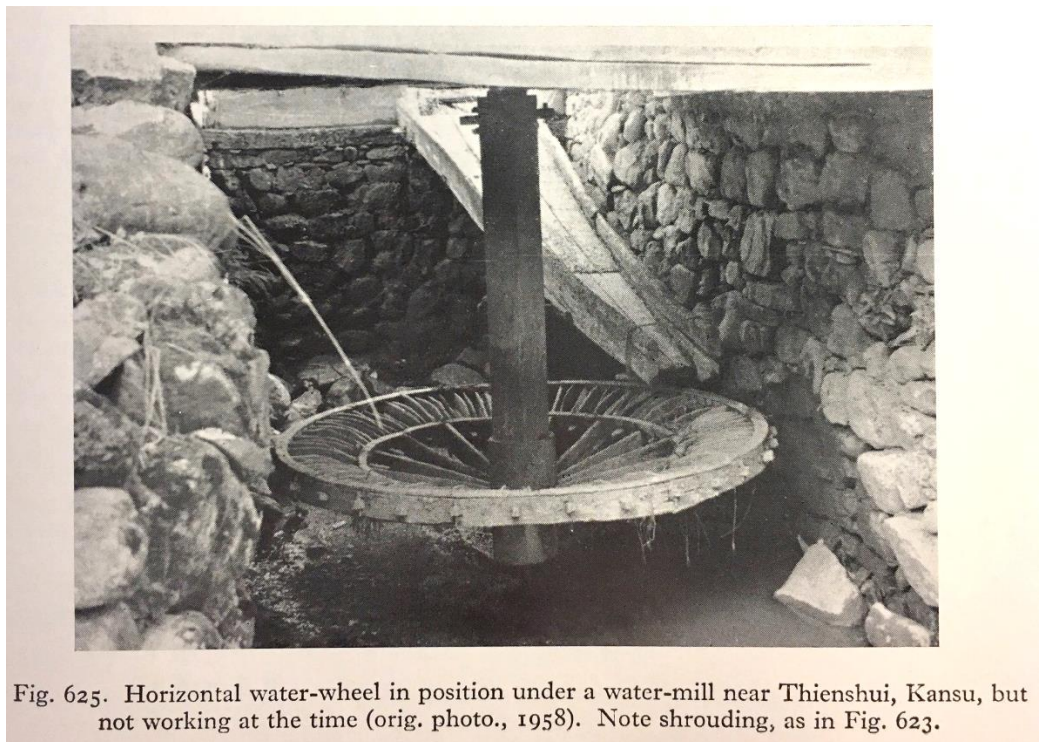
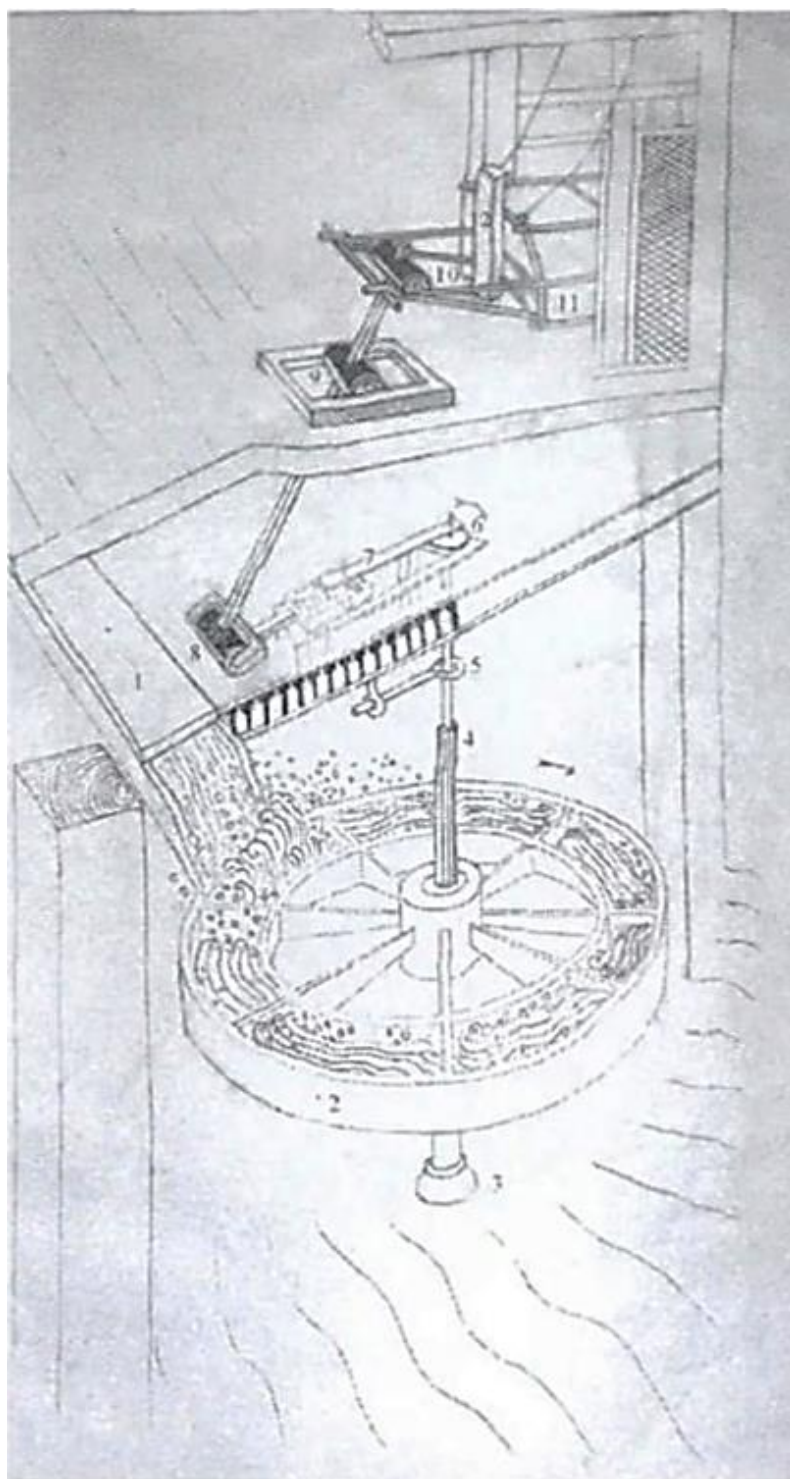


Fig. 625. Horizontal water-wheel in position under a water-mill near Thienshui, Kansu, but not working at the time (orig. photo., 1958). Note shrouding, as in Fig. 623.

Figure 257

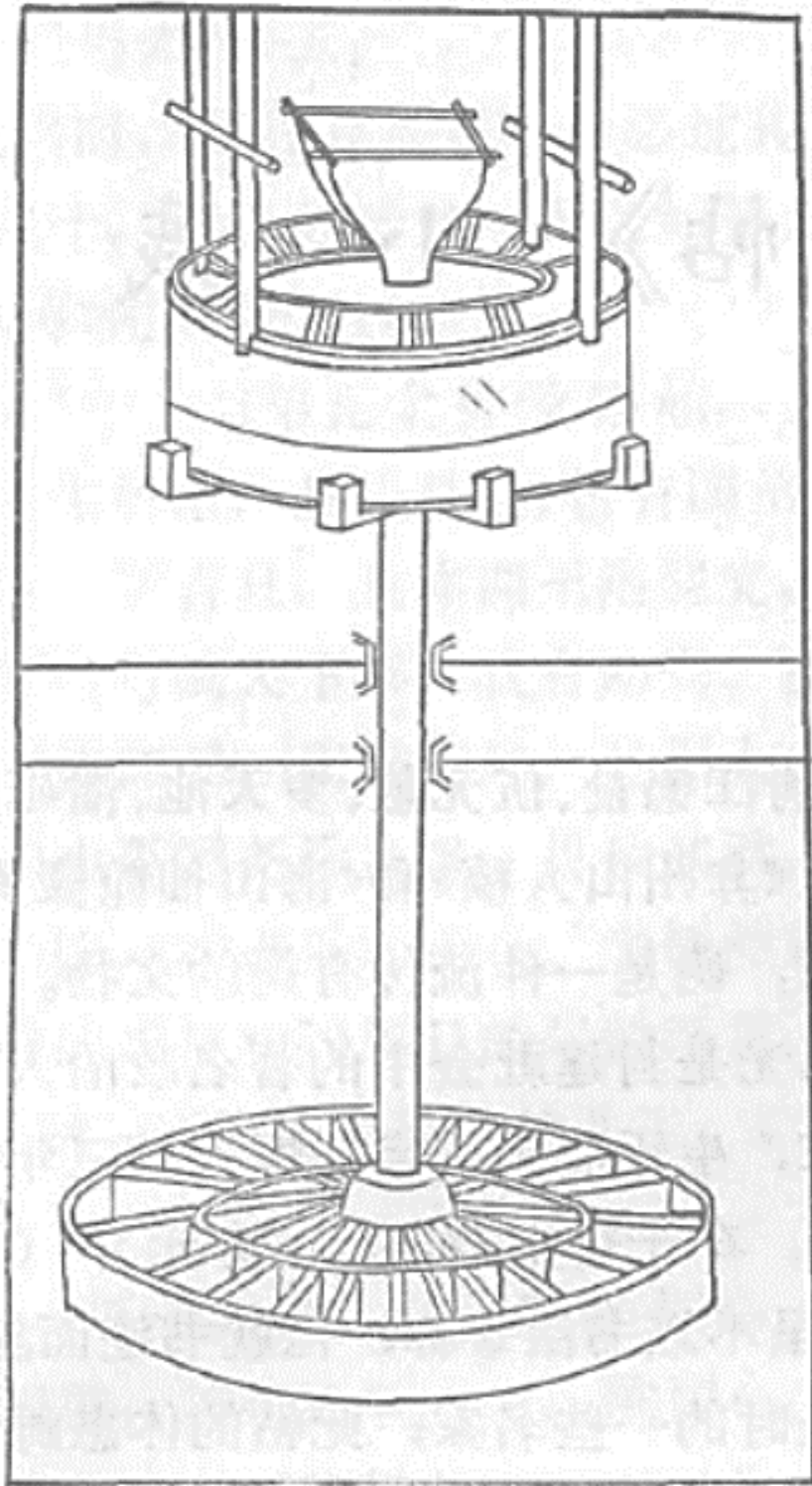
(Image from *Science and Civilisation in China*, vol 4, part 2, 399)



- 1.木水槽 2.卧水轮 3.轴承 4.轮轴 5.加固装置
 6.偏心轮 7.偏心连杆 8.下轴承 9.中轴承
 10.上轴承 11.面罗把手及面罗 12.桩柱

Figure 258

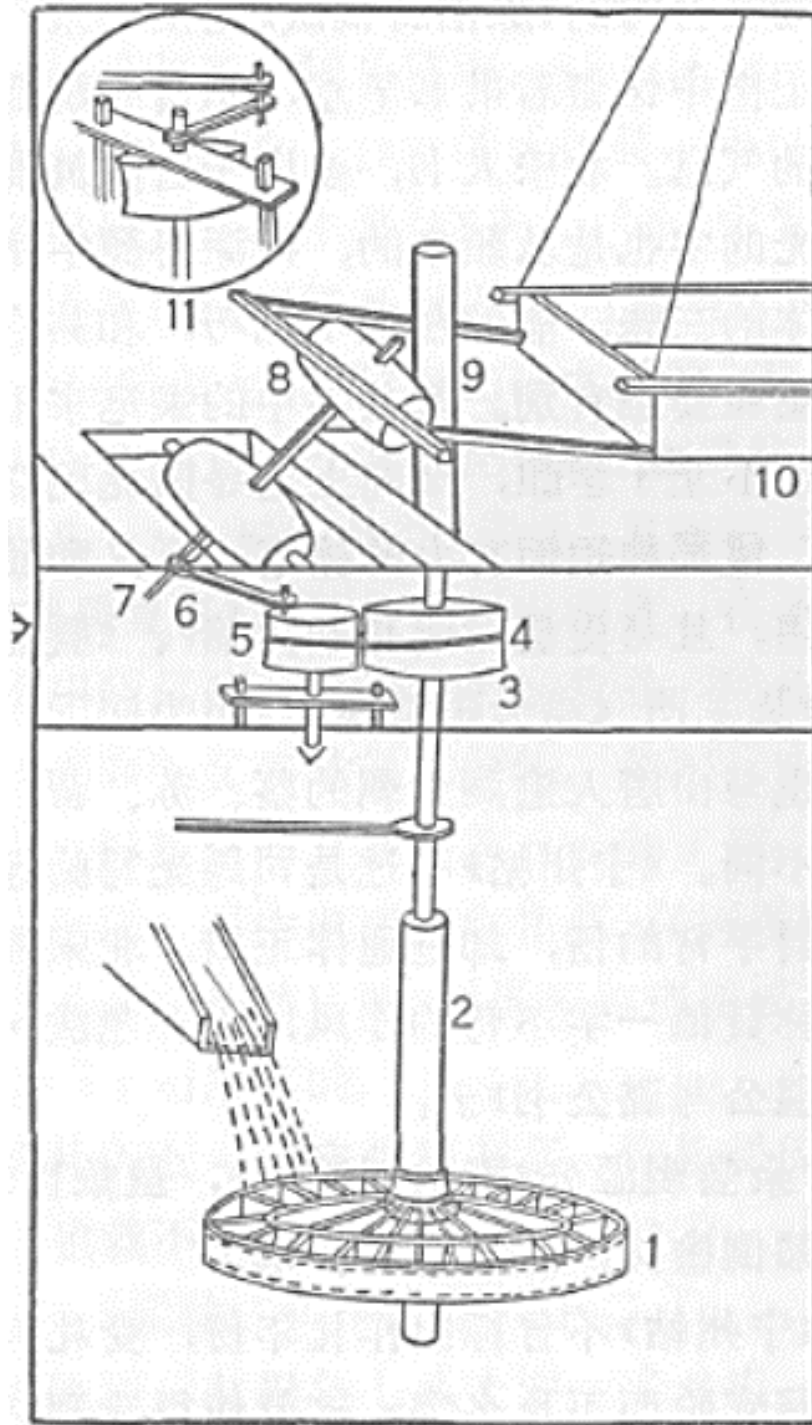
The construction of the flour sifter in *The Water Mill*
 (Image from *Agricultural Archaeology*, 2015:3, 199)



图一〇 閘口盘車图中的水磨结构

Figure 259

Line drawing of the water mill in *The Water Mill*
(Image from *Wenwu*, 1966:2)



图一二 開口盘車图中的面罗结构
 1. 下輪 2. 立軸 3. 上輪 4. 弦索 5. 旋鼓
 6. 掉枝 7. 行枕 8. 鼓木 9. 撞柱 10. 面罗
 11. 旋鼓和掉枝部份另一种結構的可能

Figure 260
 Line drawing of the flour sifter in *The Water Mill*
 (Image from *Wenwu*, 1966:2)

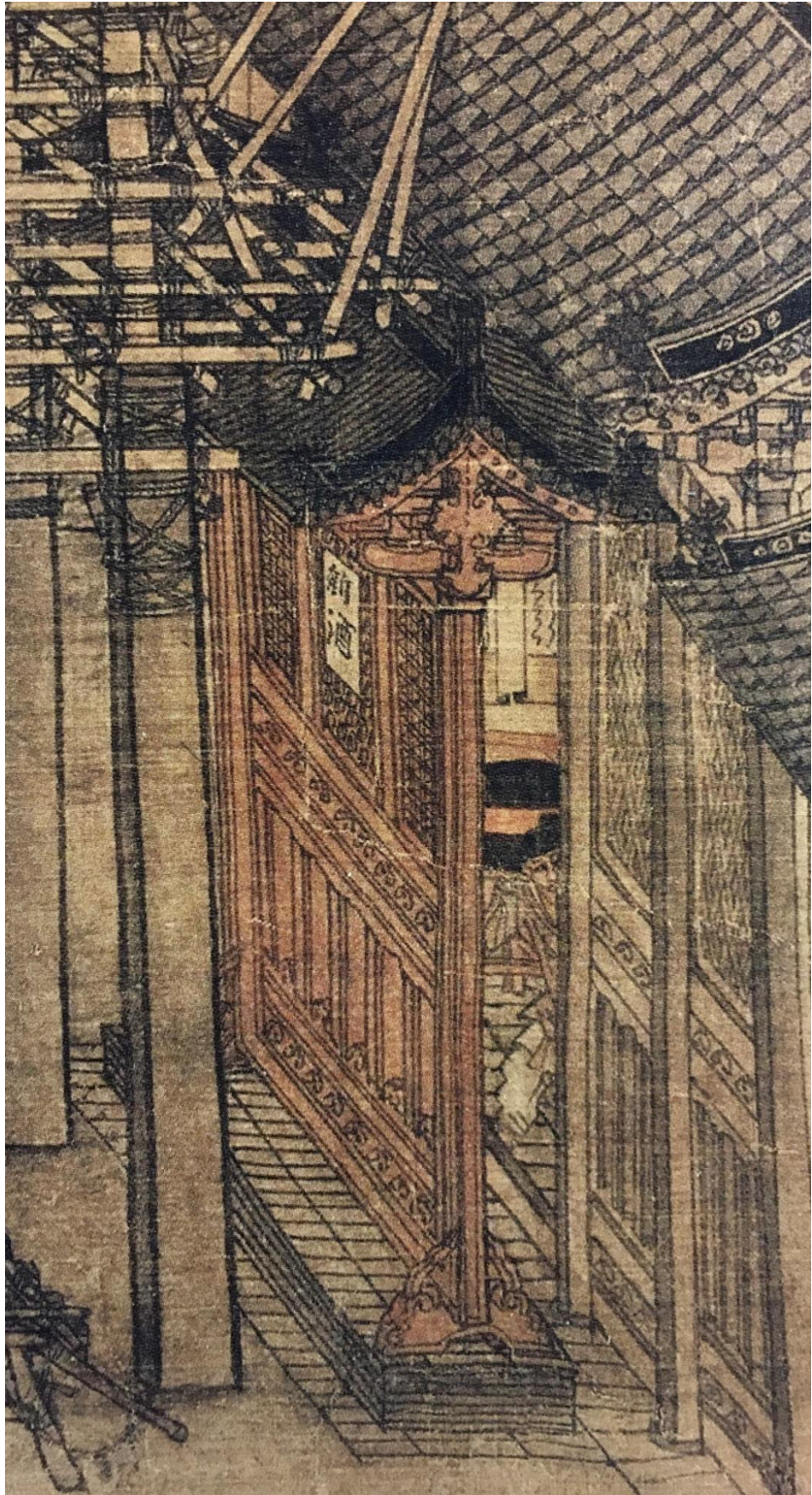


Figure 261
Detail of *The Water Mill*, the *luli*

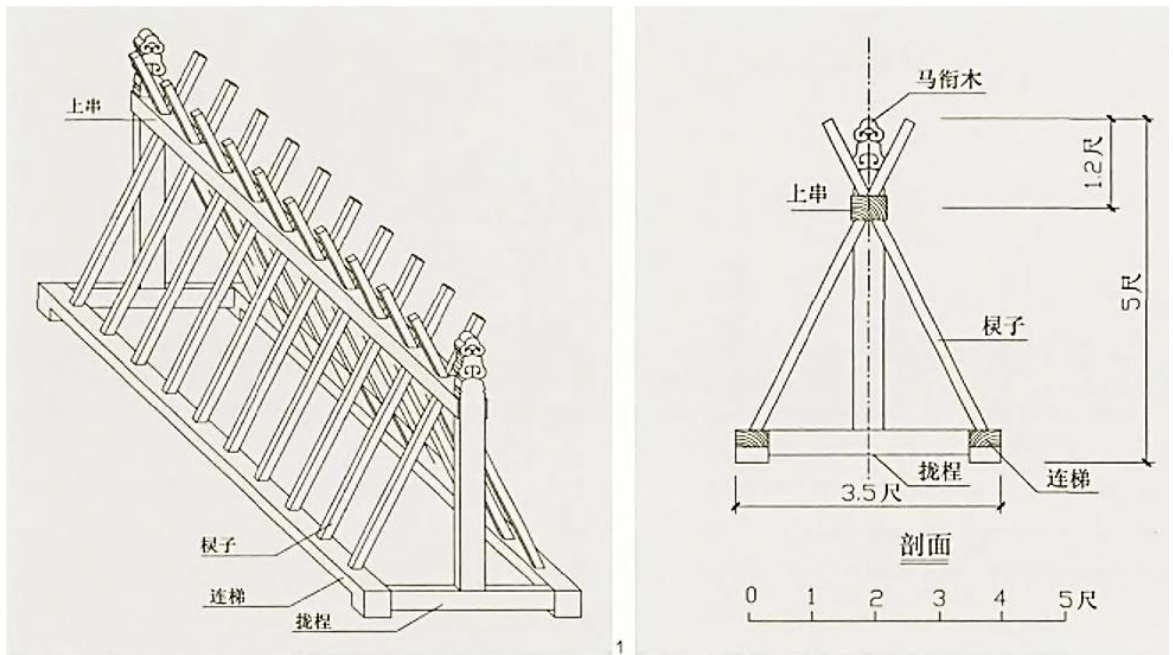


Figure 262

Illustration of the *juma chazi* according to *Yingzao fashi*
 (Image from *Traditional Chinese Architecture and Gardens*, 2016:2, 18)

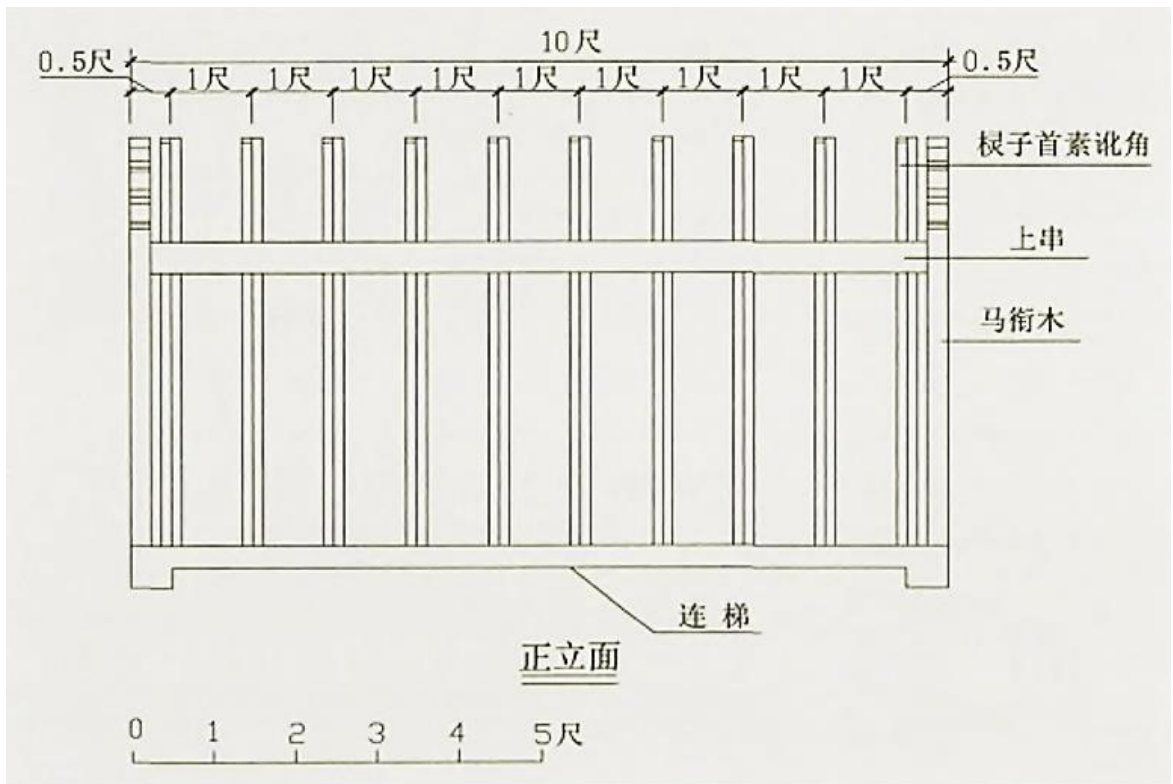


Figure 263

Frontal illustration of the *juma chazi* according to *Yingzao fashi*
 (Image from *Traditional Chinese Architecture and Gardens*, 2016:2, 18)

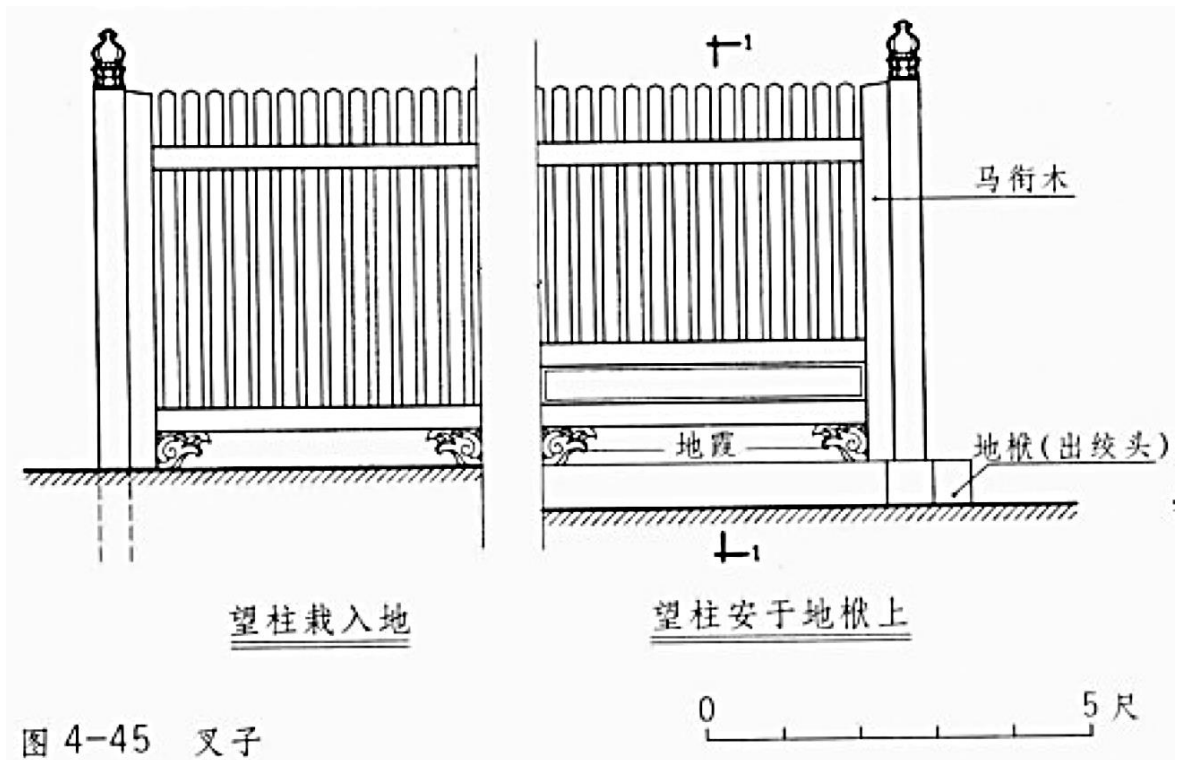


Figure 264
The *chazi* of *Yingzao fashi*
(Image from '*Yingzao fashi*' *jiedu*, 130)



Figure 265
Detail of *Along the River During the Qingming Festival*, the *chazi* of "Sunyang zhengdian"

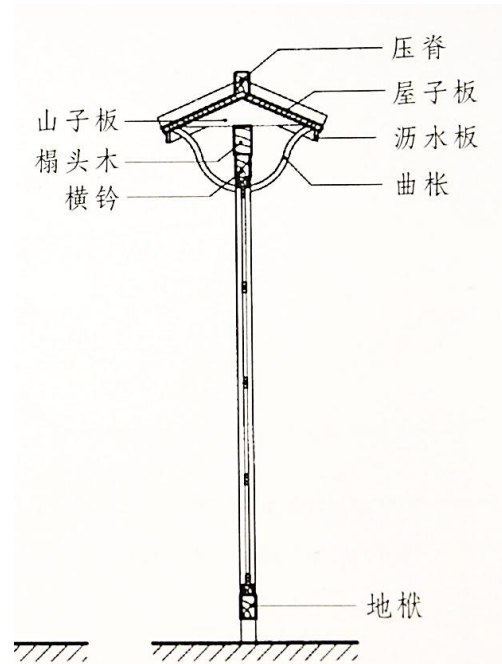


Figure 268
 Profile illustration of *luli* by Pan Guxi and He Jianzhong
 (Image from 'Yingzao fashi' jiedu, 132)



Figure 269
 Detail of *The Water Mill*, the pyramidal thatched roof with tiles of the right pavilion

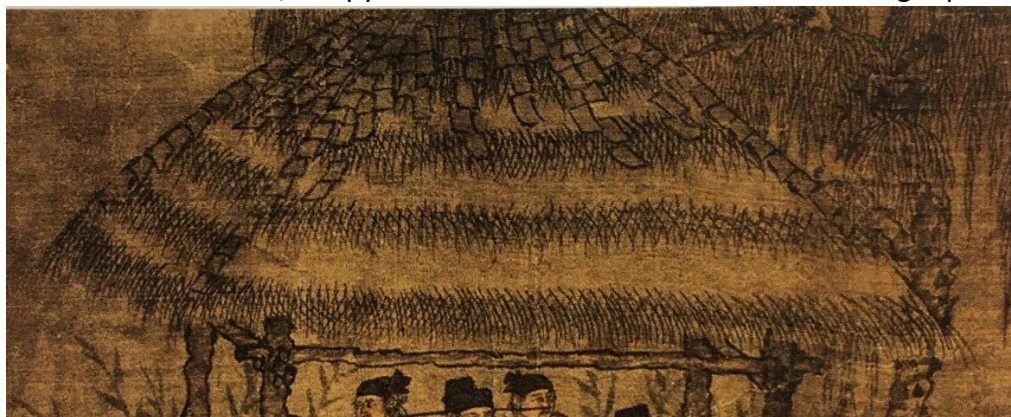


Figure 270
 Detail of *The Water Mill*, the pyramidal thatched roof with tiles of the right pavilion

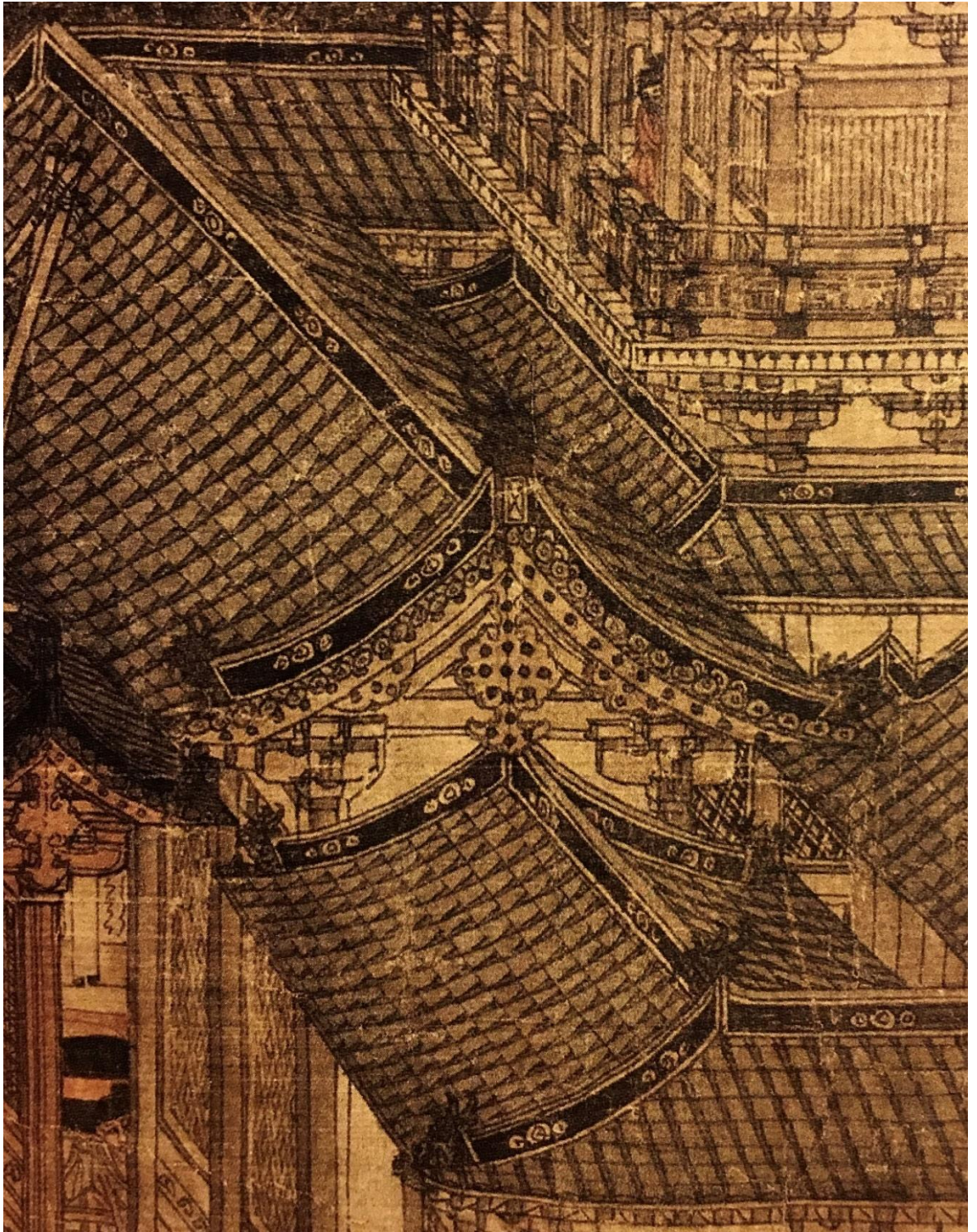


Figure 271
Detail of *The Water Mill*, the roof construction

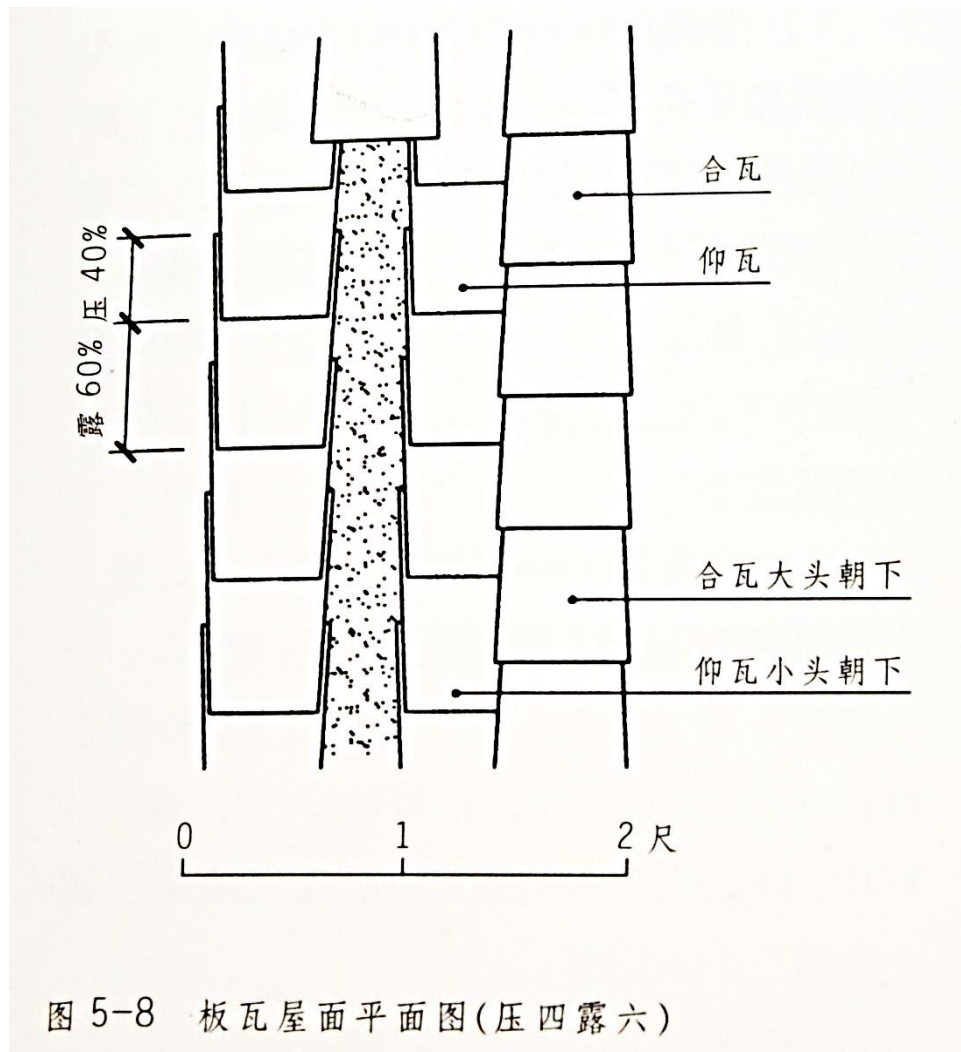


图 5-8 板瓦屋面平面图(压四露六)

Figure 272
Standard roof tiles of the Song Dynasty
(Image from 'Yingzao fashi' jiedu, 160)

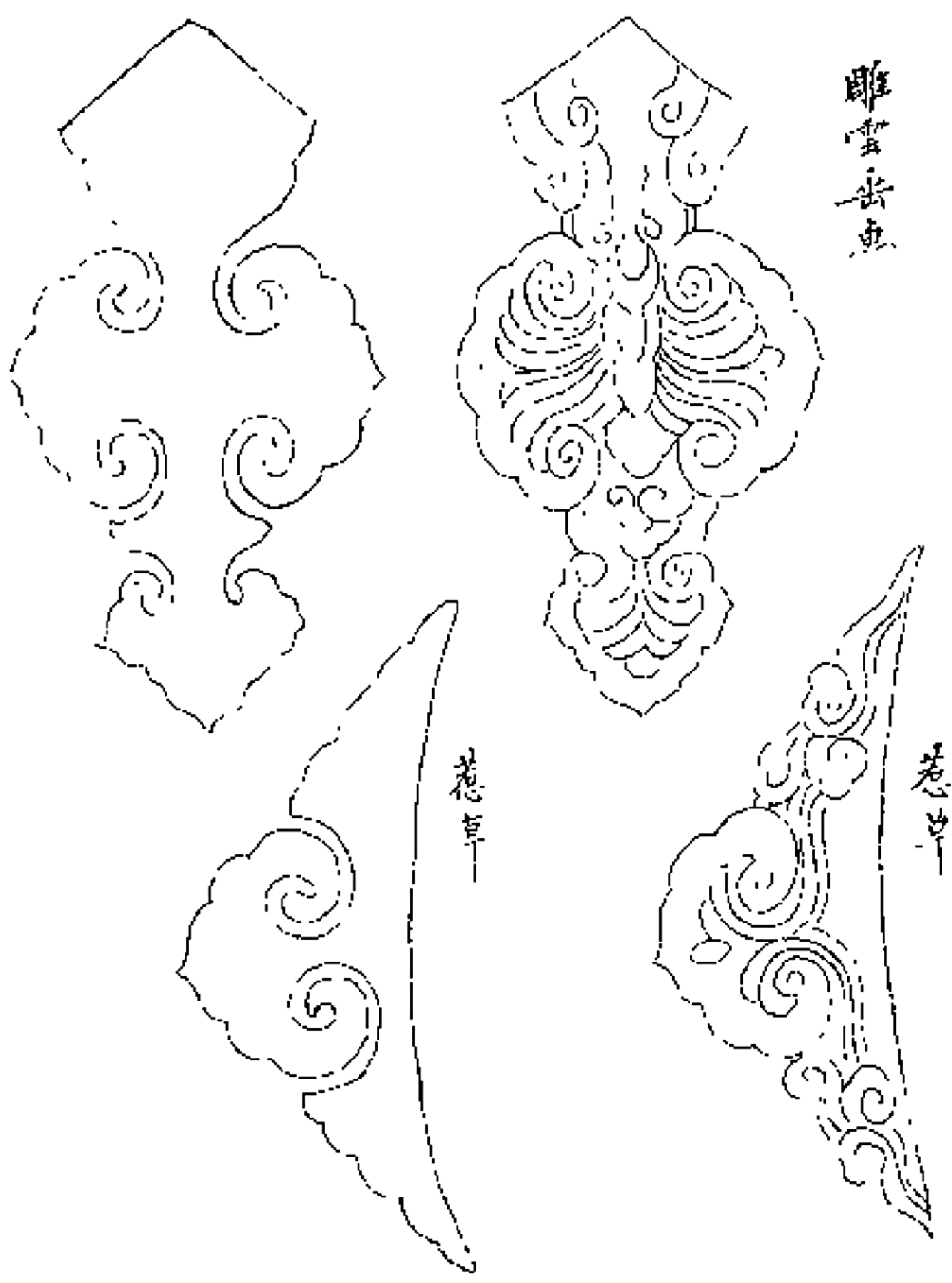


Figure 274
The *xuanyu* and *recao* of *Yingzao fashi*
(Image from *Yingzao fashi*, vol 32)



Figure 275
The *xuanyu* of Chuzu An
(Photo by ZX)

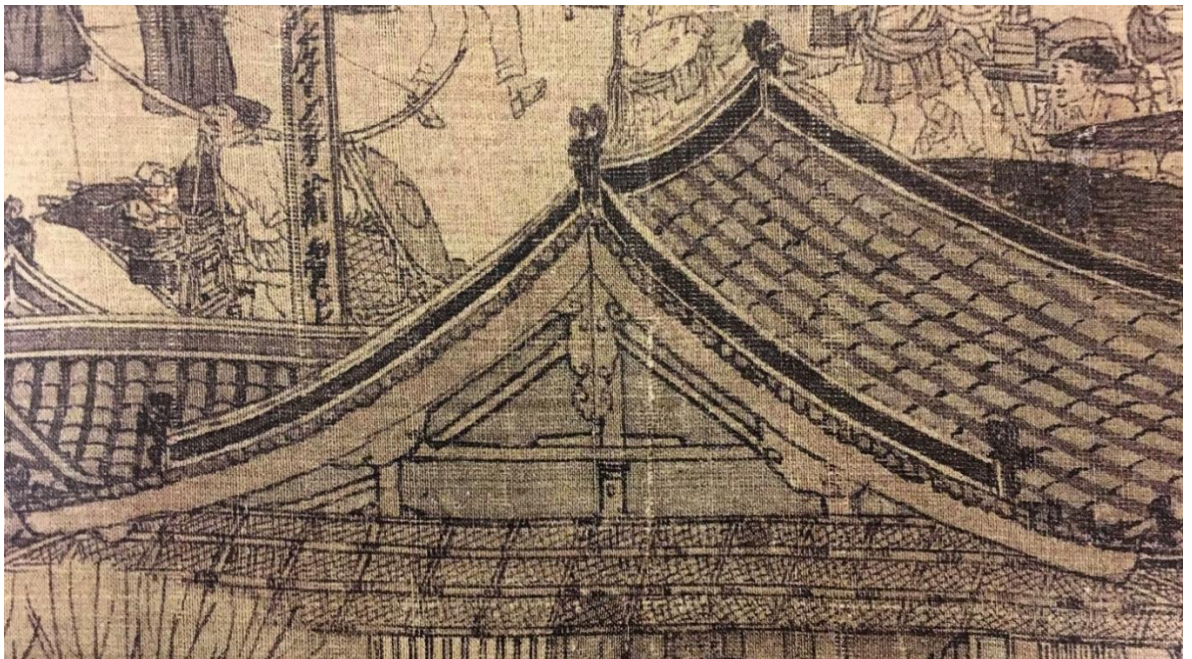


Figure 276
Detail of *Along the River During the Qingming Festival*, the *xuanyu* and *recao* of a building



Figure 277

Detail of *Along the River During the Qingming Festival*, the *xuanyu* and *recao* of a building



Figure 278

Detail of *Along the River During the Qingming Festival*, the *xuanyu* and *recao* of a building

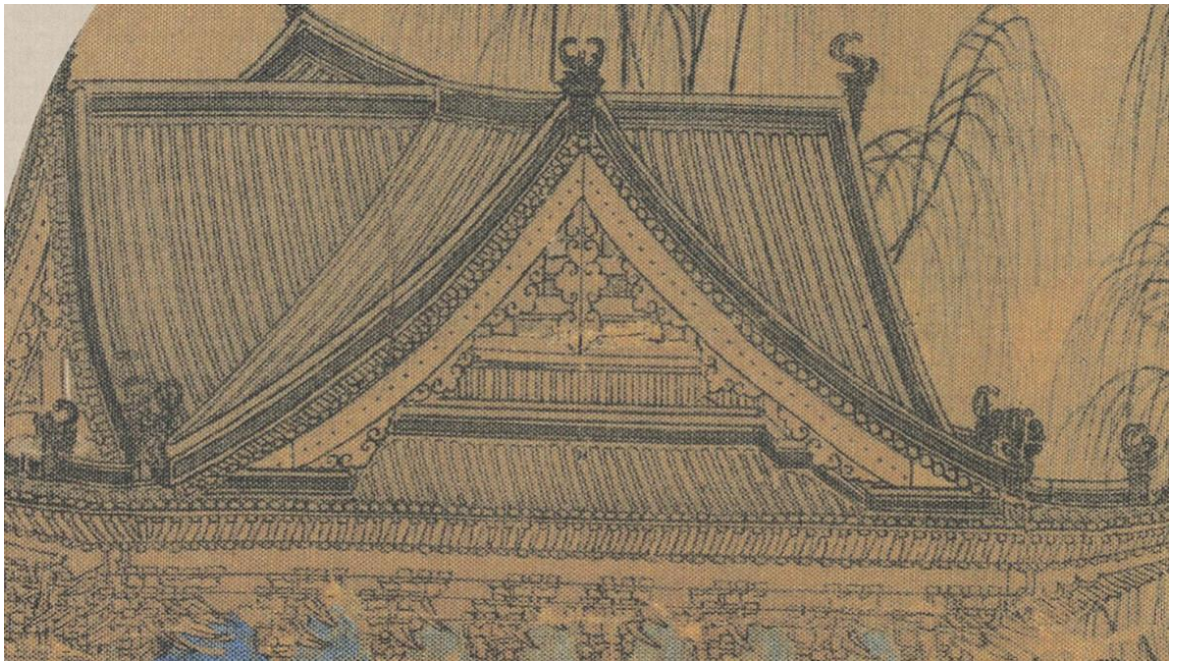


Figure 279
Detail of *Shuidian zhaoliang tu*, the *xuanyu* and *recao* of the building



Figure 280
Detail of *Four Seasons Landscape Paintings*, the *xuanyu* and *recao* of the building

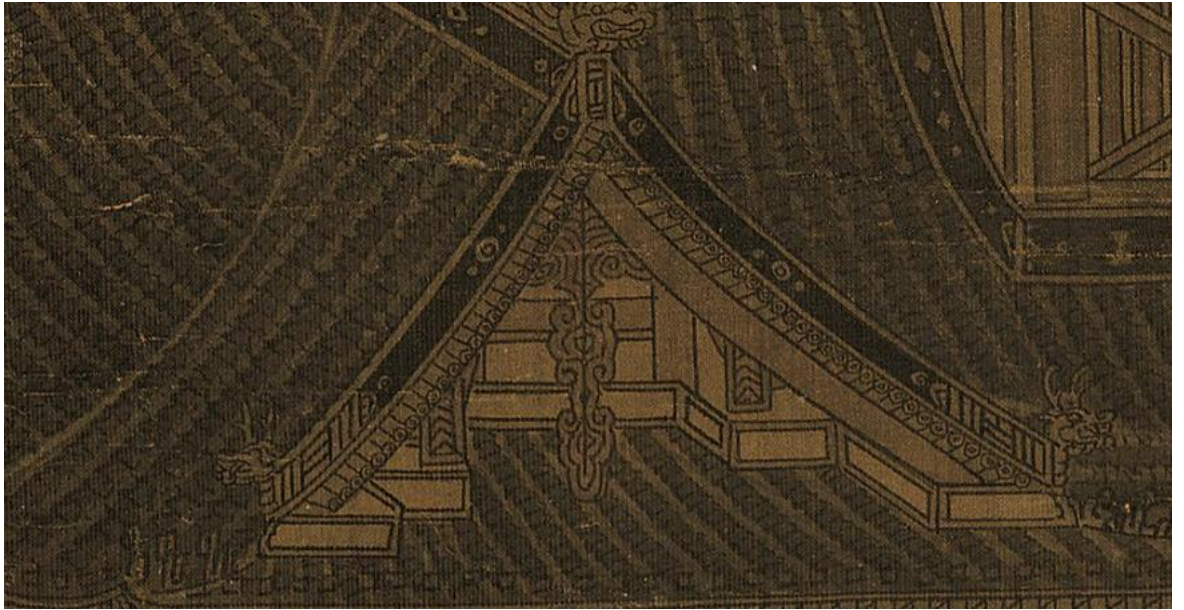


Figure 281

Detail of *The Water Mill in Valley*, the *xuanyu* of the water mill hall

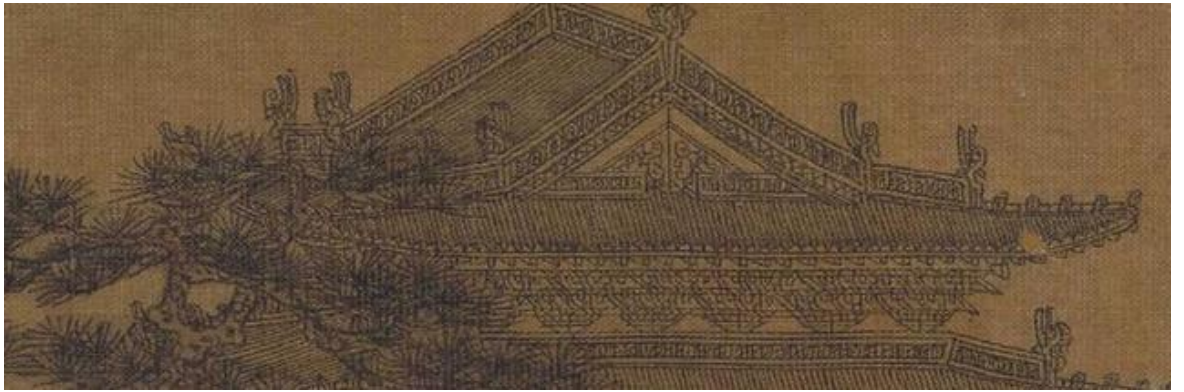


Figure 282

Detail of *Yueyang Tower*, the *xuanyu* of the building

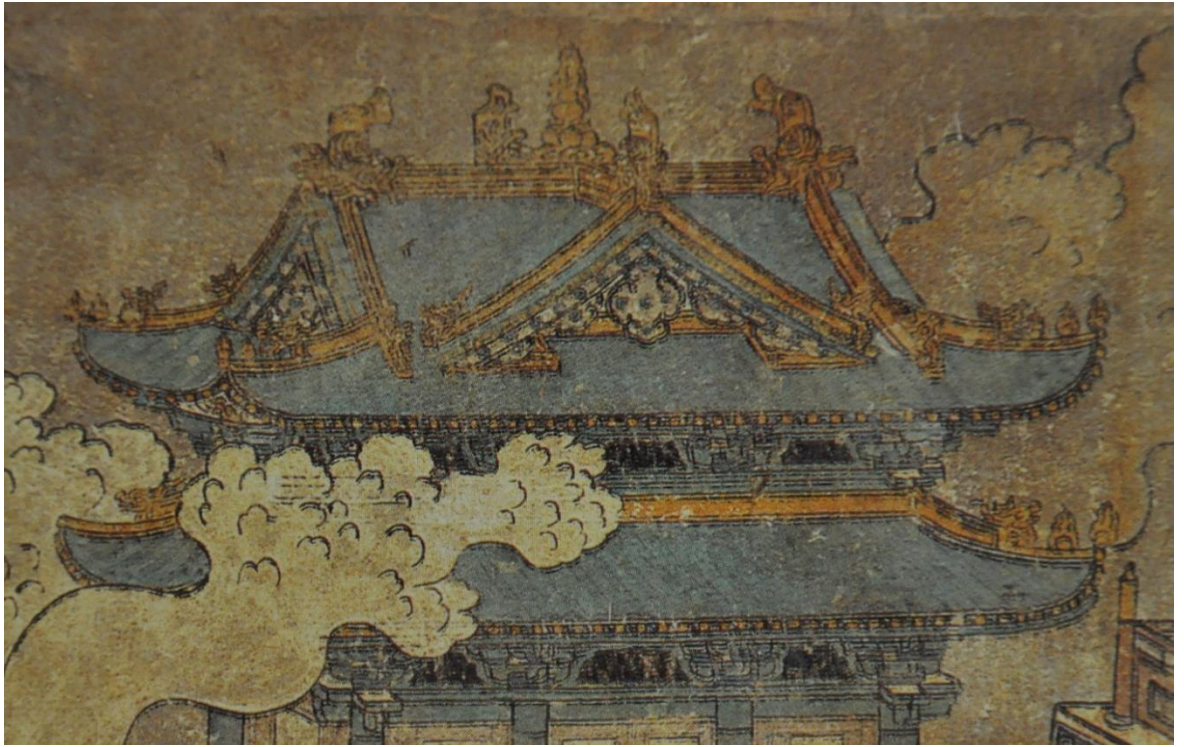


Figure 283
The *xuanyu* of a building, mural painting, from the Yongle Palace

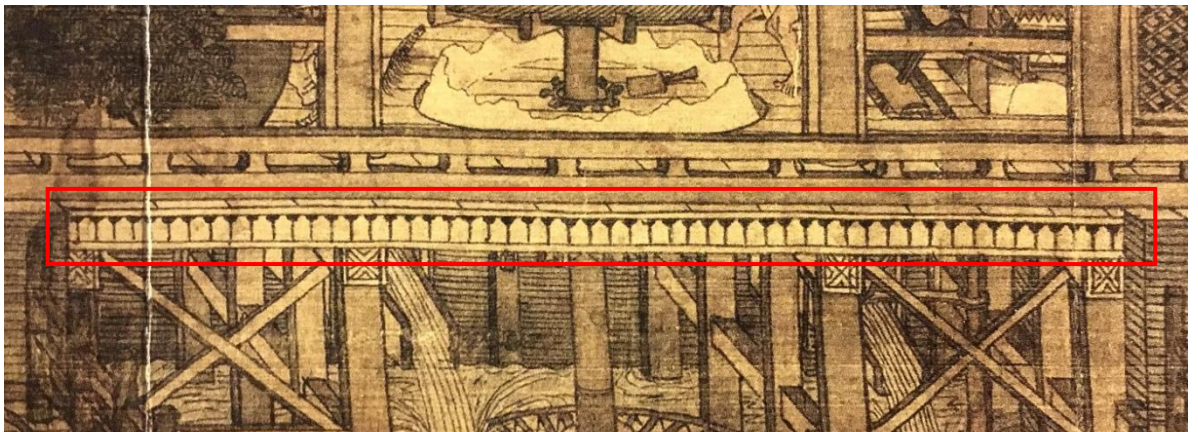


Figure 284

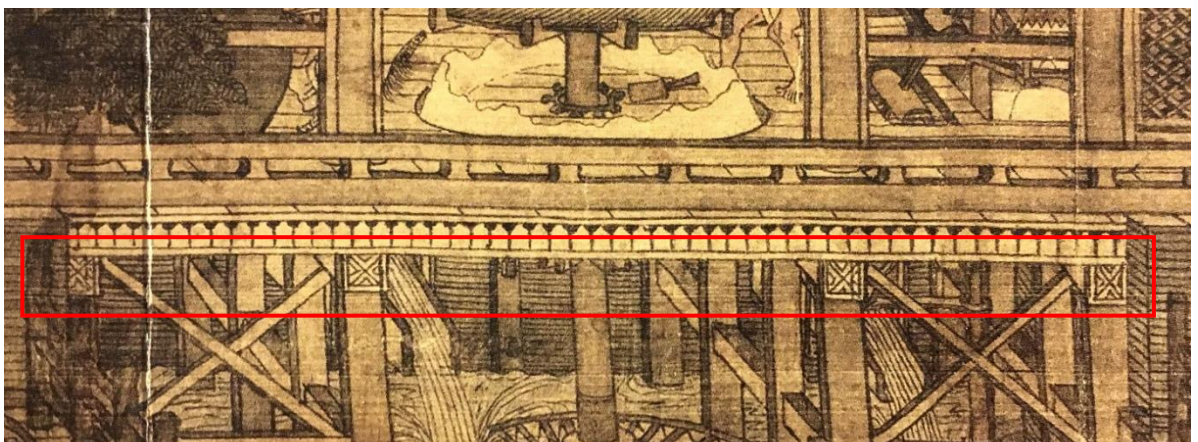


Figure 285

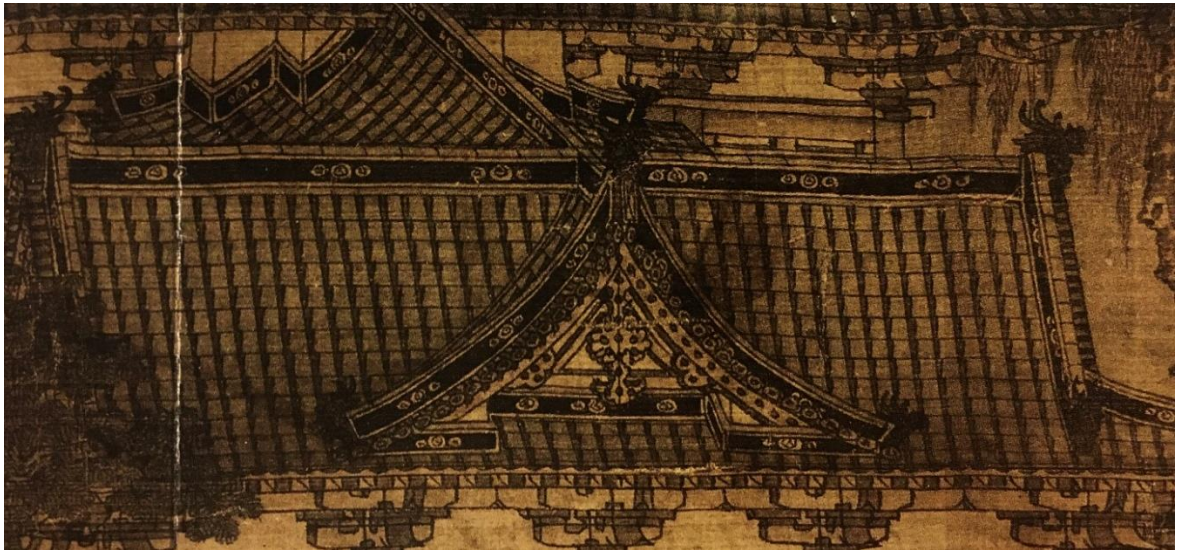


Figure 286



Figure 287

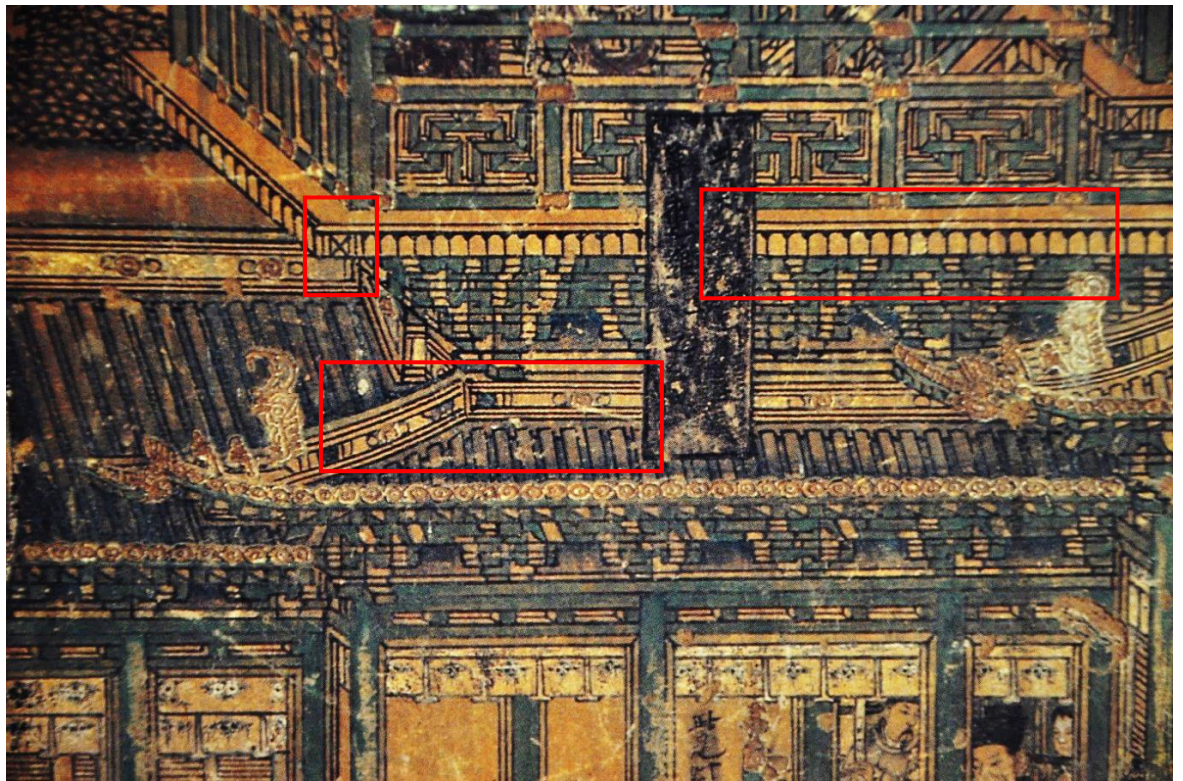


Figure 288

Detail of the mural painting of fanshan Temple, the white pentagon pattern, the crossed pattern and the round pattern

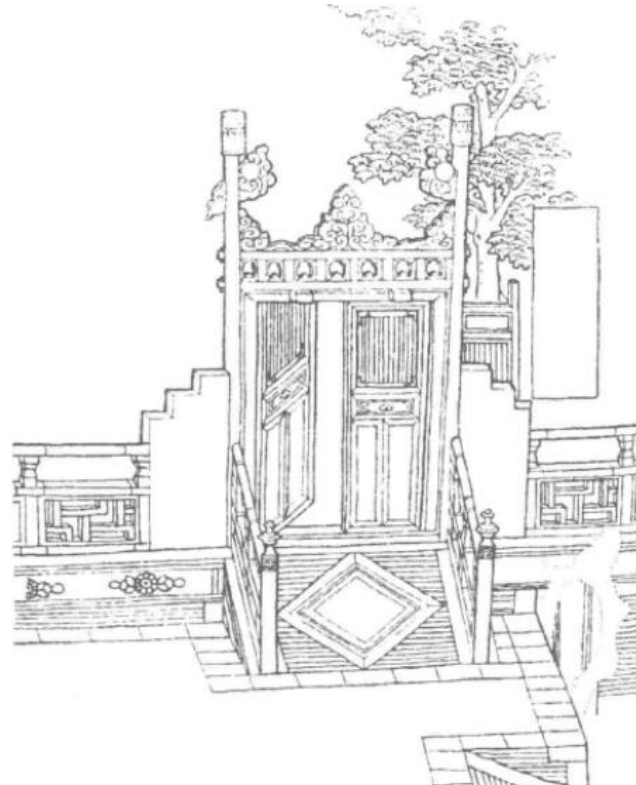


Figure 289

A line drawing of the mural painting of Yanshan Temple, the large diamond pattern of the ramp stair

(Image from *Architectural History Research*, 1982:1, 83)



Figure 290
Detail of *The Water Mill*, the closed cart

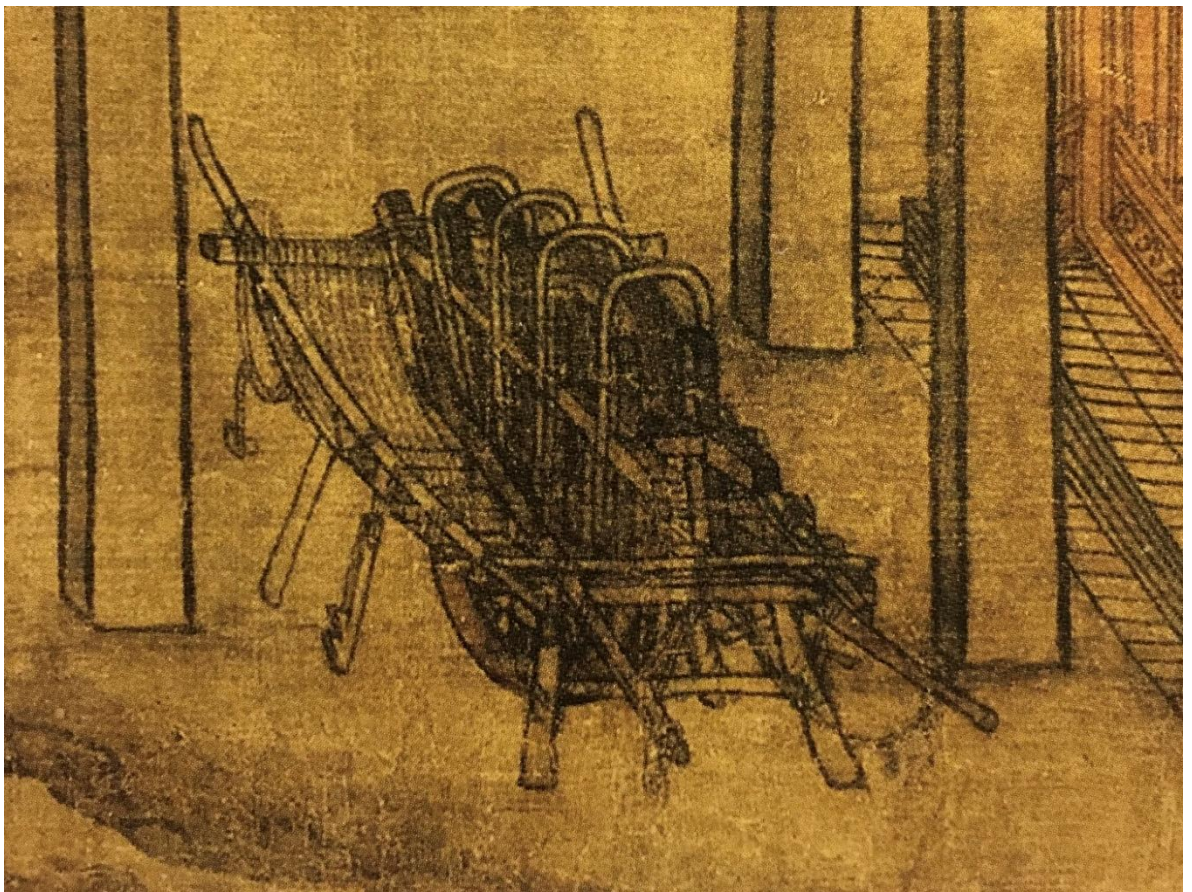


Figure 291
Detail of *The Water Mill*, the wheelbarrow



Figure 292

Detail of *Along the River During the Qingming Festival*, the oxen carts



Figure 293

Detail of *Transport Carts* (Palace Museum), the oxen carts
(Image from *ZGMSQJ*, Painting Collection vol 4, 6)



Figure 294
Detail of *The Water Mill in Valley*, the oxen carts



Figure 295
Detail of *Landscape of Travelling in Winter*, the oxen carts
(Image from ZGMSQJ, Painting Collection vol 4, 5)



Figure 296

Detail of *Travelling among Mountains and Brooks*, the oxen carts
(Image from ZGMSQJ, Painting Collection vol 4, 4)



Figure 297

Detail of *Transport Carts* (Museum of Fine Arts), the oxen carts



Figure 298
Zhu Rui (attrib.)
Landscape of Travelling in Winter
Colours on silk, 26 x 24.8 cm
Shanghai Museum, Shanghai
(Image from *ZGMSQJ*, vol 4, 5)

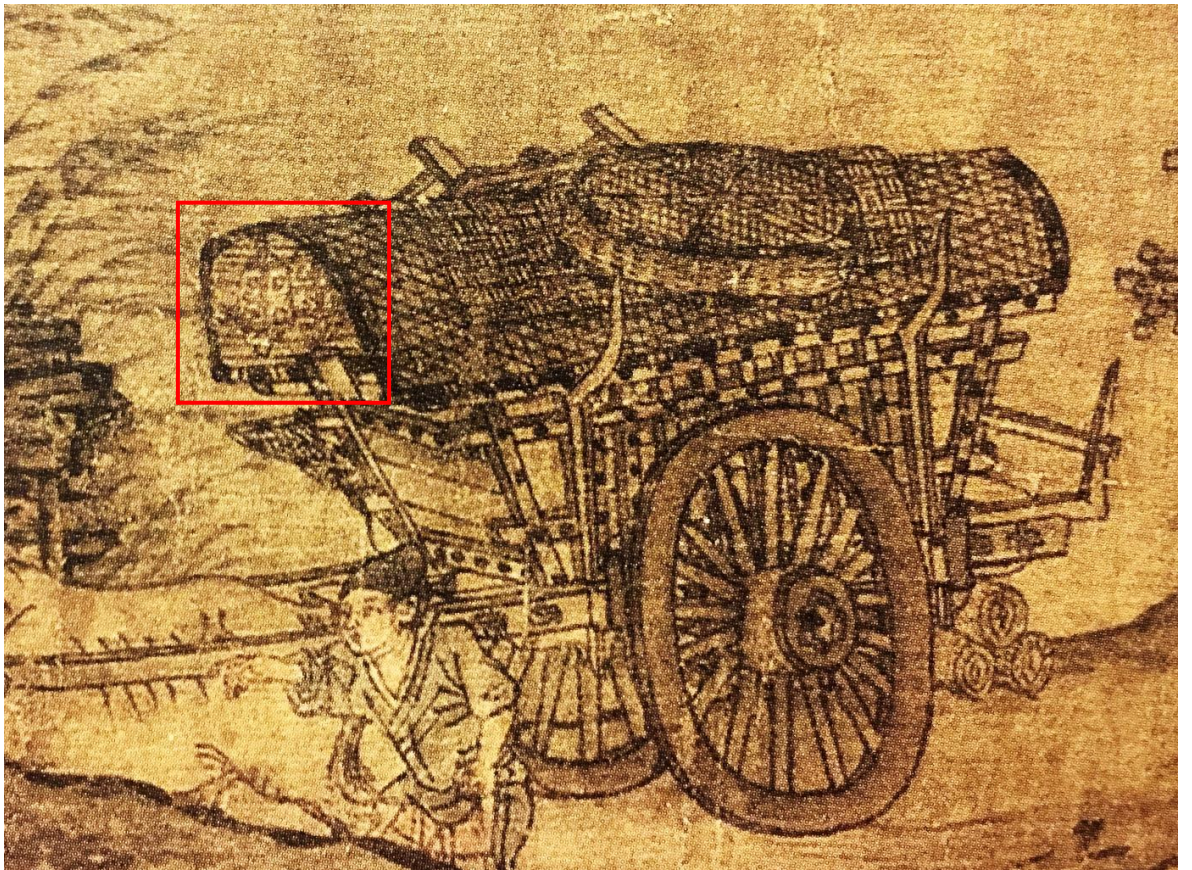


Figure 299

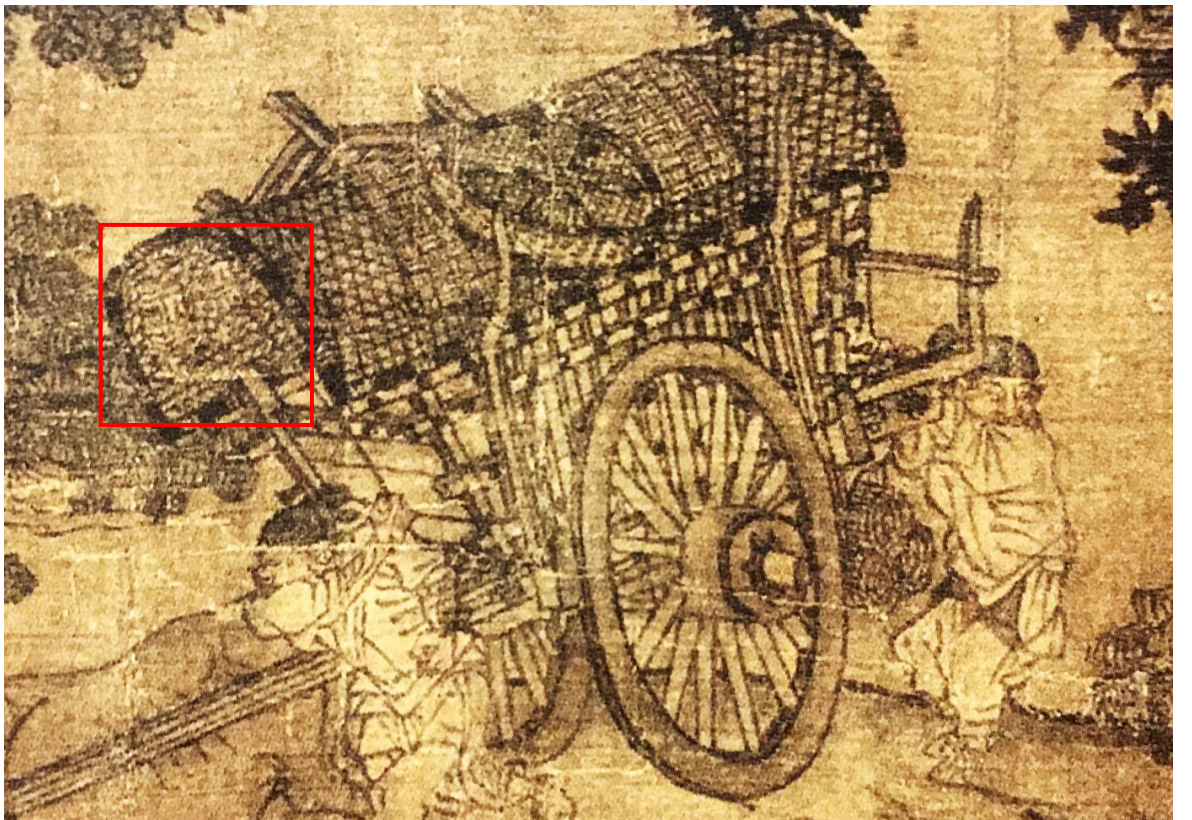


Figure 300

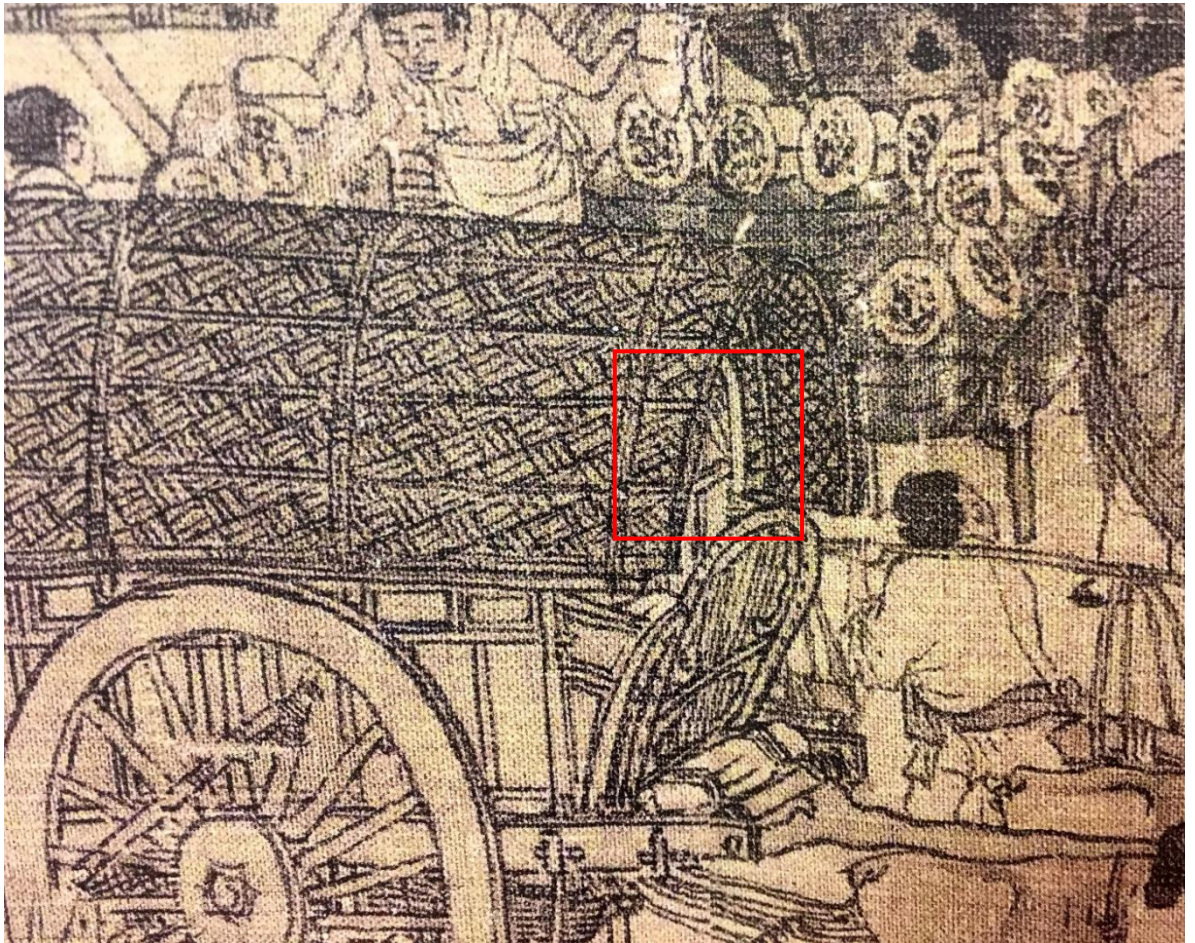


Figure 301

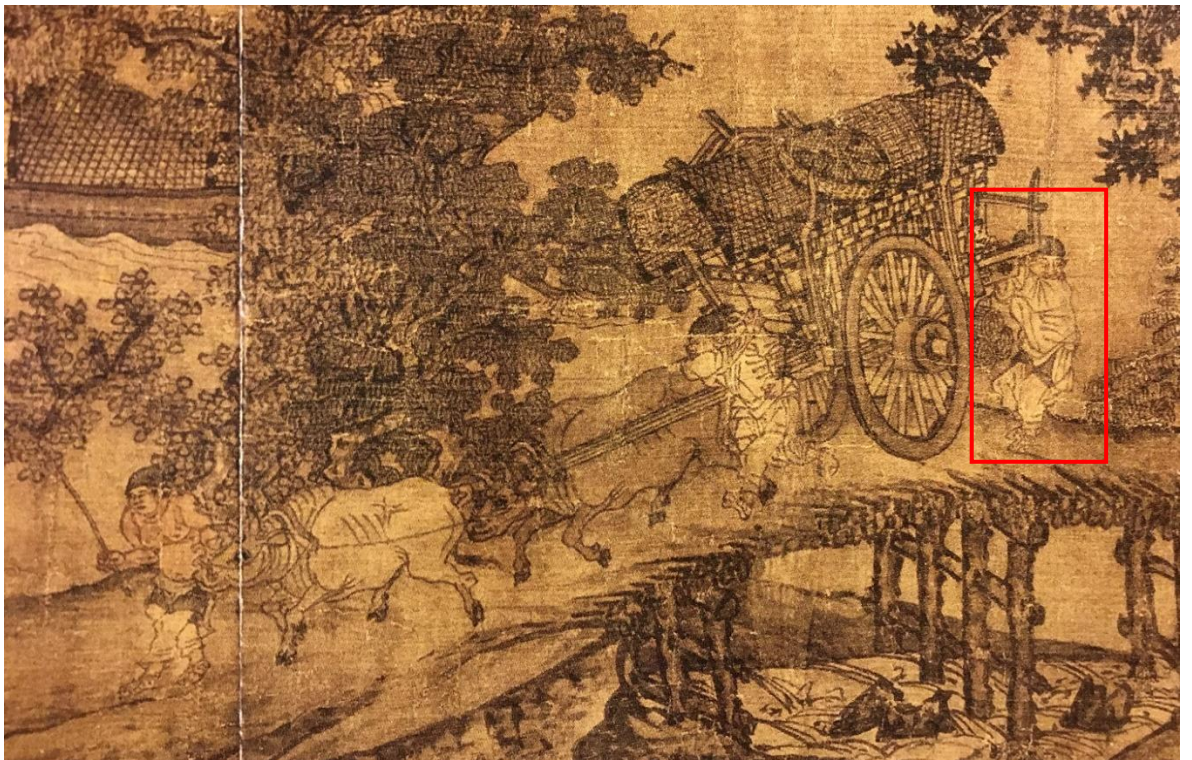


Figure 302

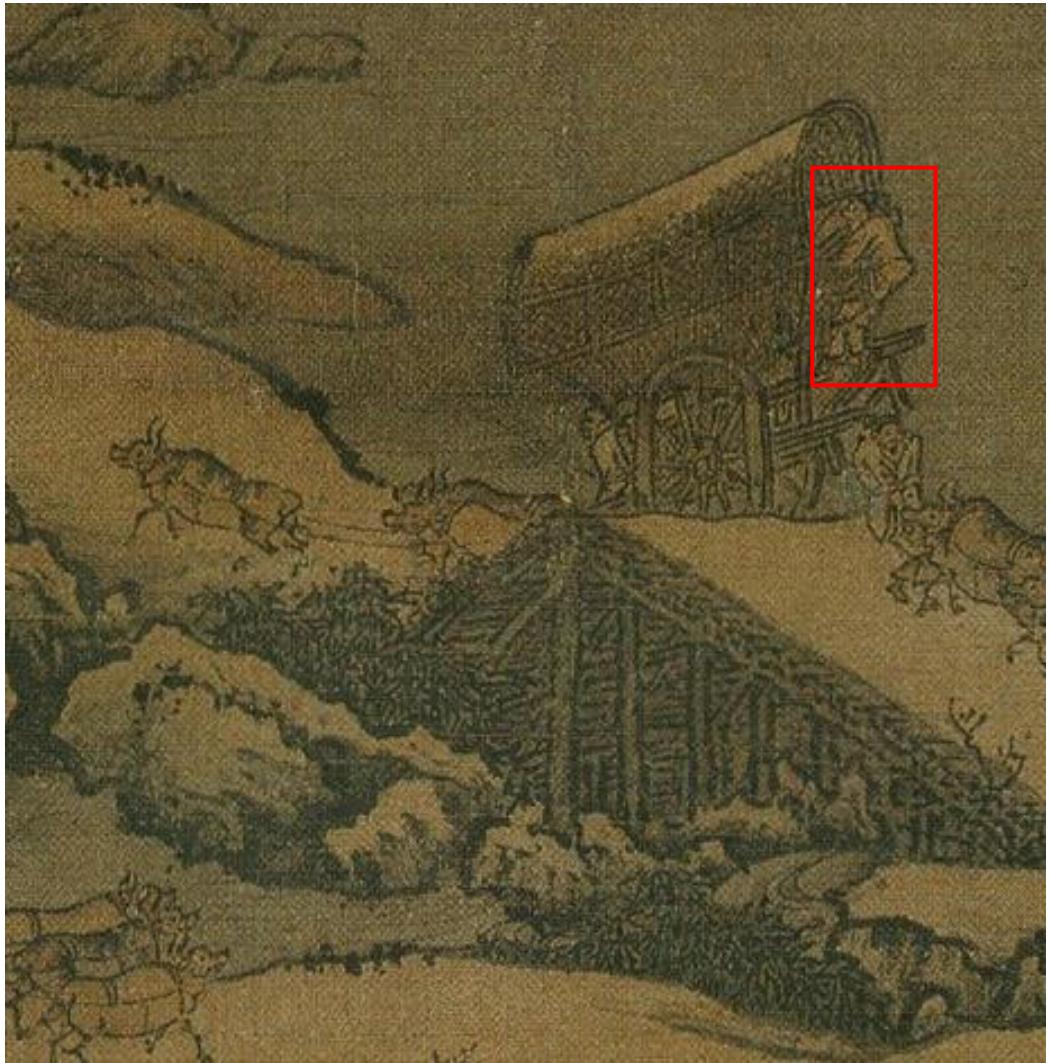


Figure 303

Detail of *Landscape of Travelling in Winter*, a labourer who slows down the cart

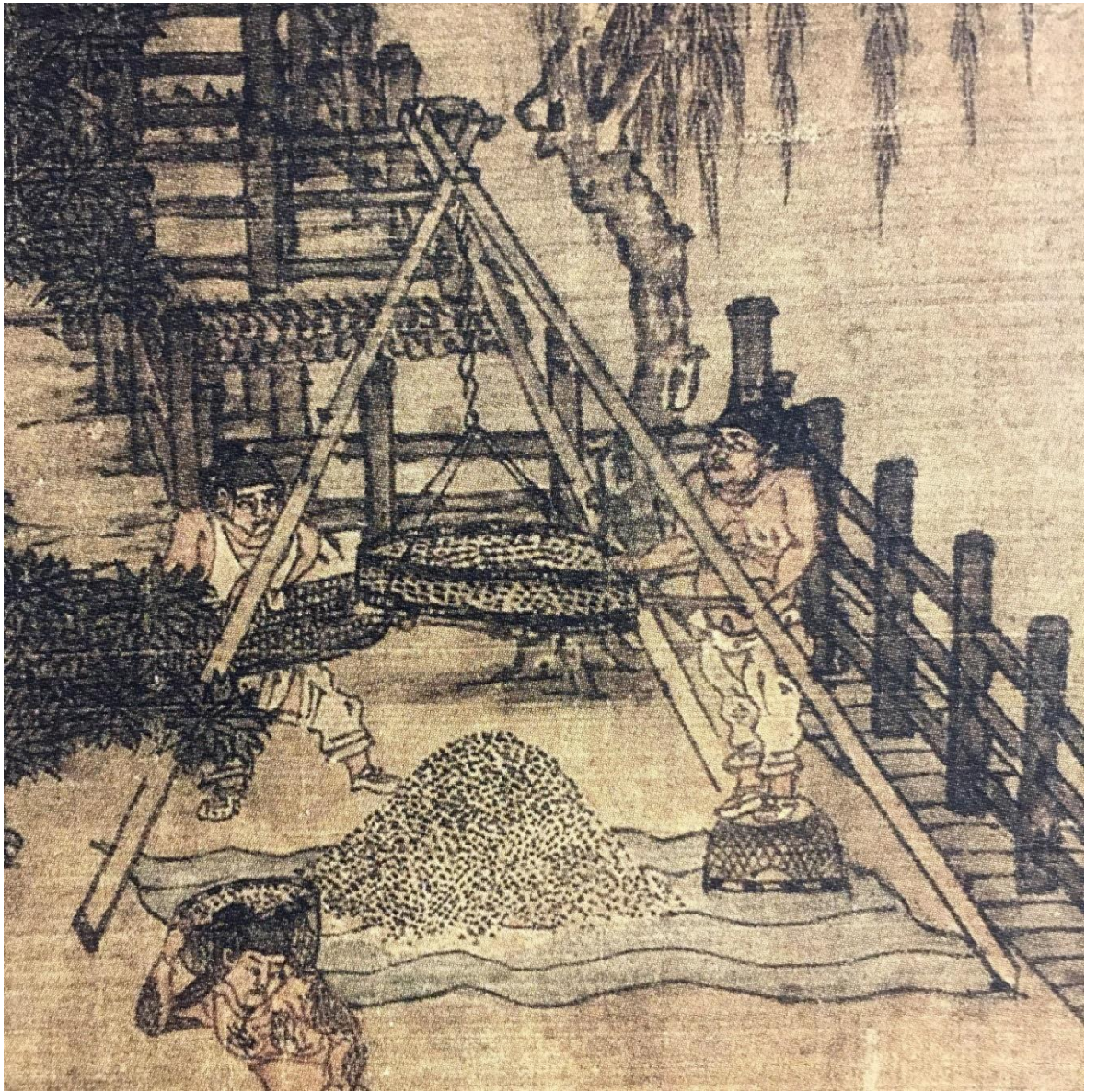


Figure 304
Detail of *The Water Mill*, the flour or wheat sifter



Figure 305

Detail of *The Water Mill*, the square stool on the cart

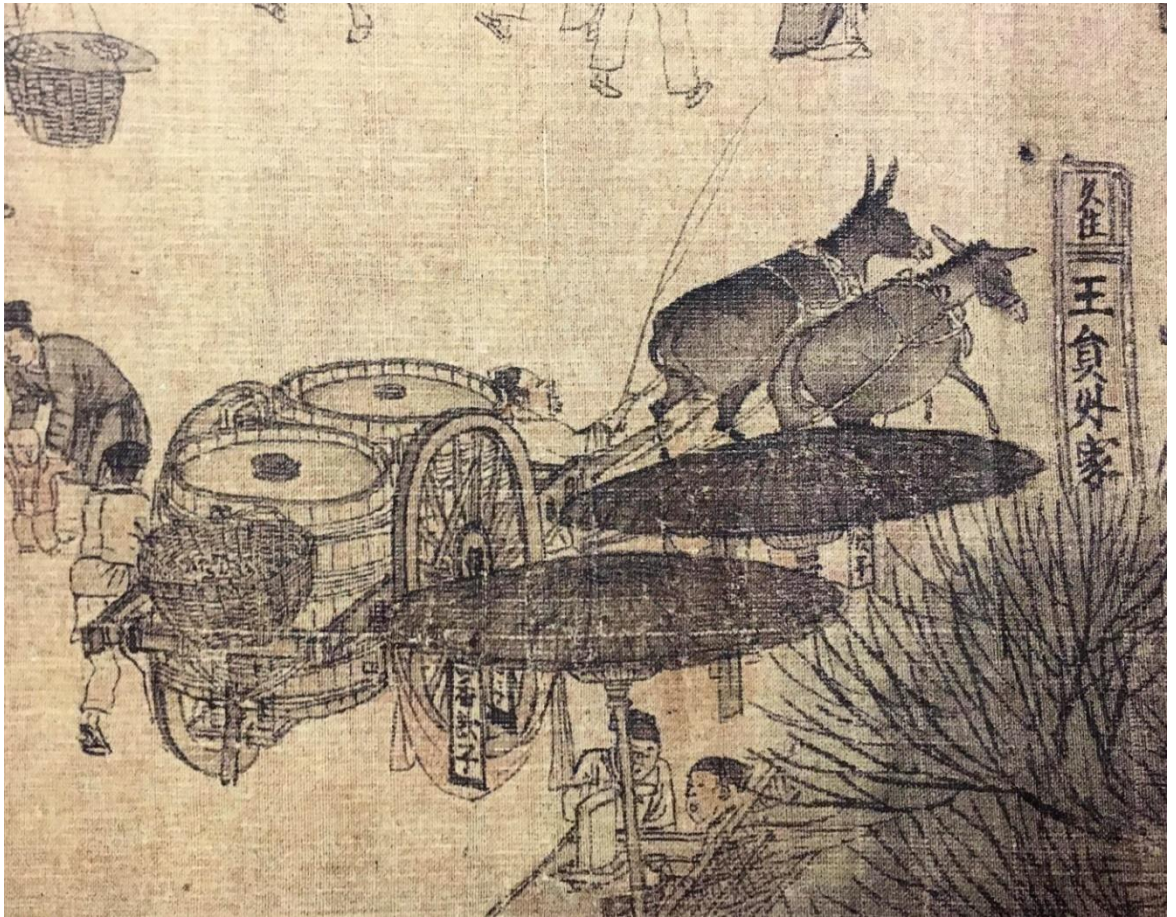


Figure 306

Detail of *Along the River During the Qingming Festival*, the pingtou cart



Figure 307

Detail of *Along the River During the Qingming Festival*, the wheelbarrow

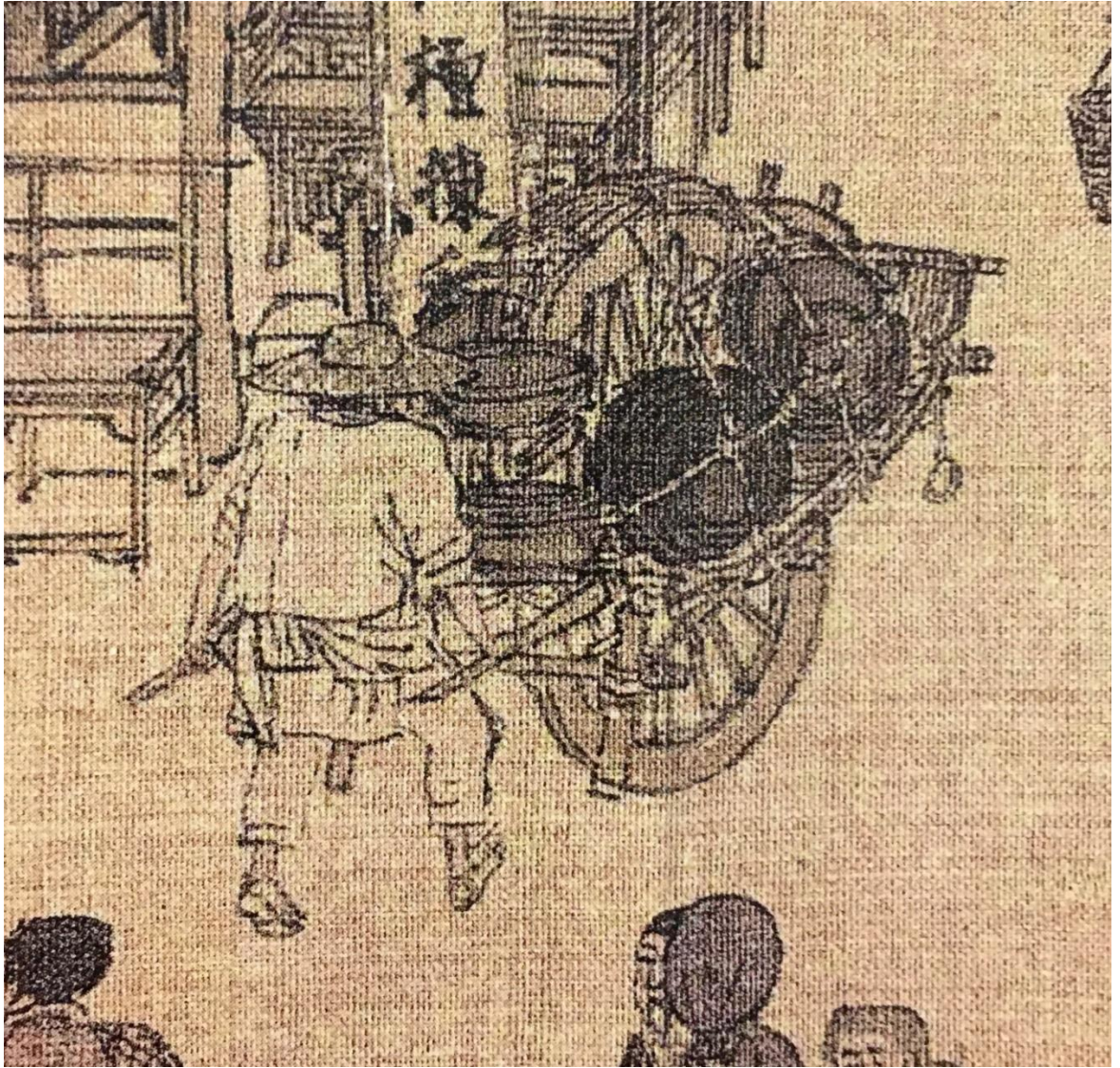


Figure 308

Detail of *Along the River During the Qingming Festival*, the wheelbarrow

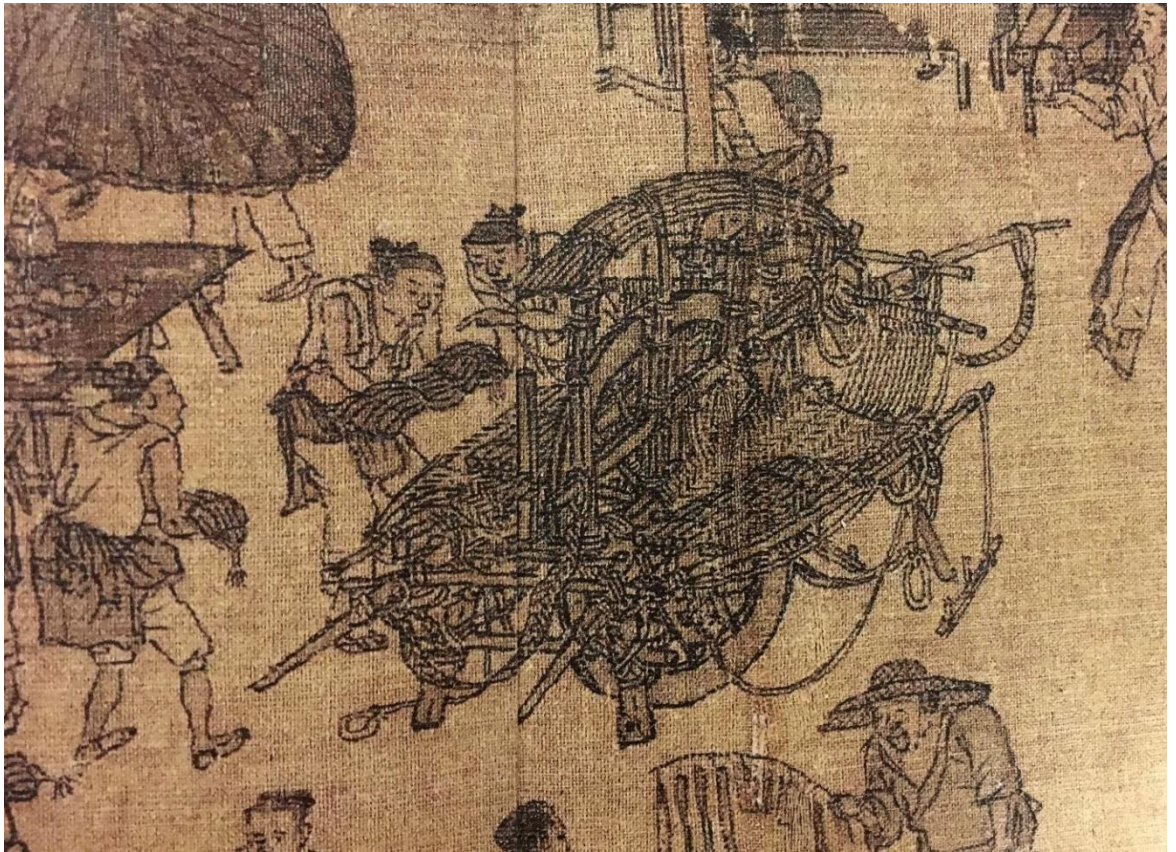


Figure 309

Detail of *Along the River During the Qingming Festival*, the wheelbarrow



Figure 310
Detail of *Transport Carts* (Palace Museum), the wheelbarrow
(Image from *ZGMSQJ*, Painting Collection vol 4, 6)

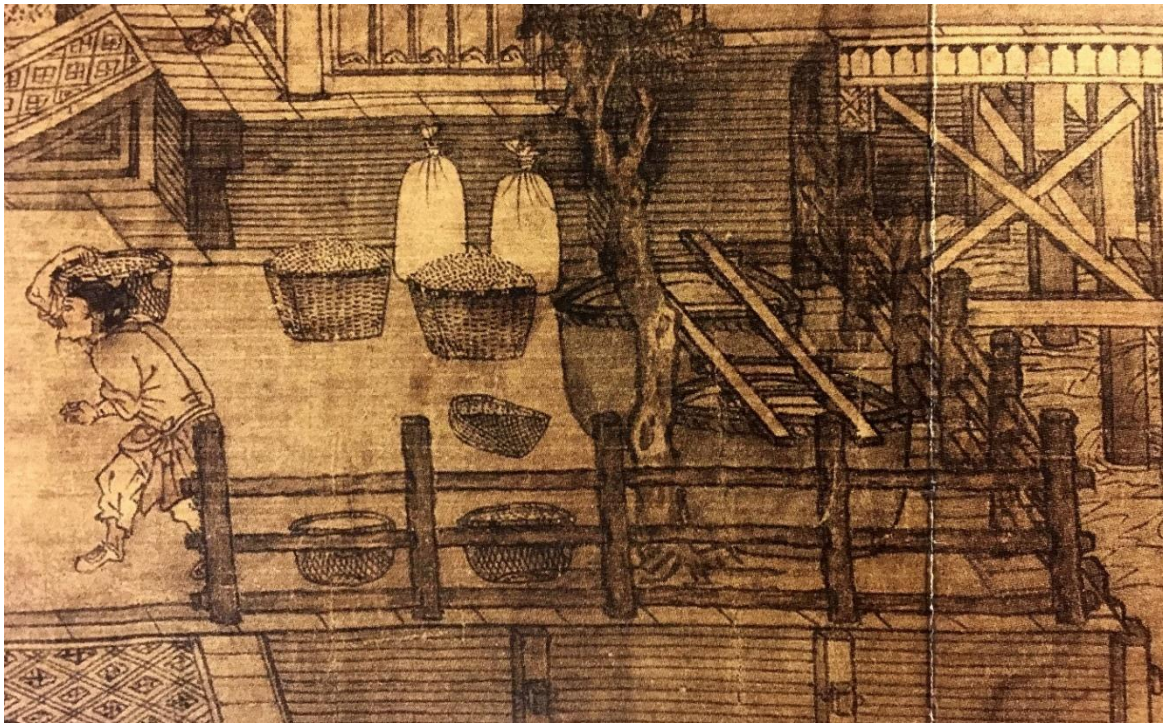


Figure 311
Detail of *The Water Mill*, the water vats and baskets at the left terrace

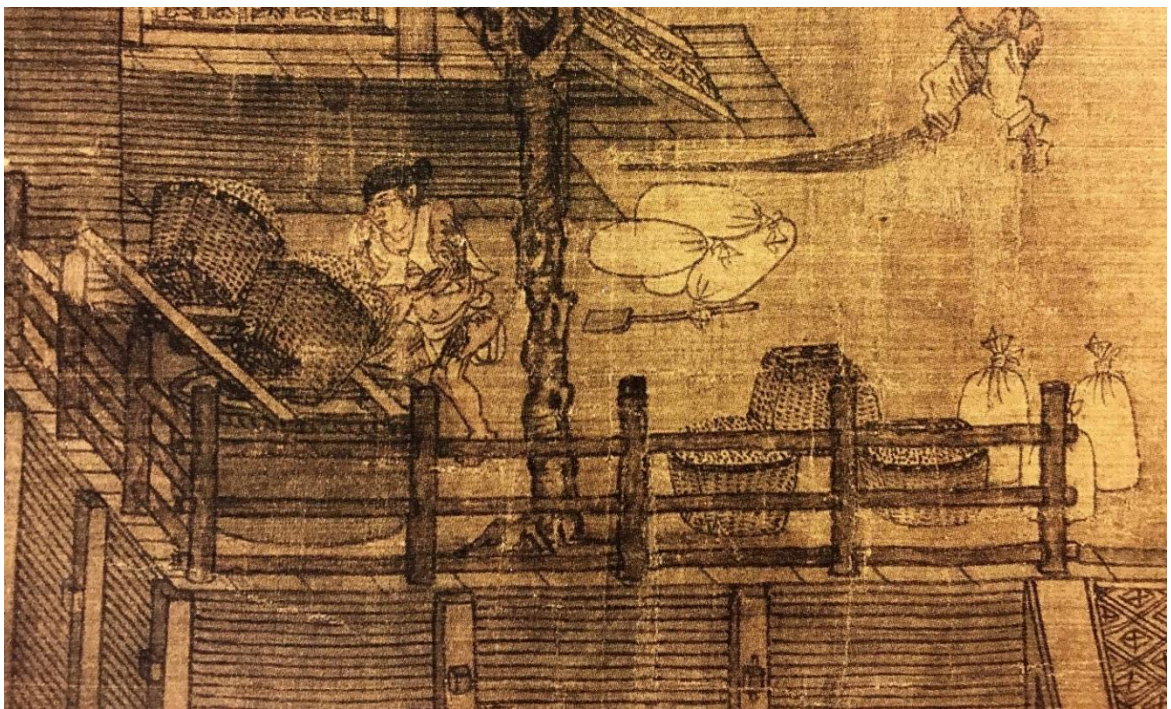


Figure 312
Detail of *The Water Mill*, the water vats and baskets at the right terrace

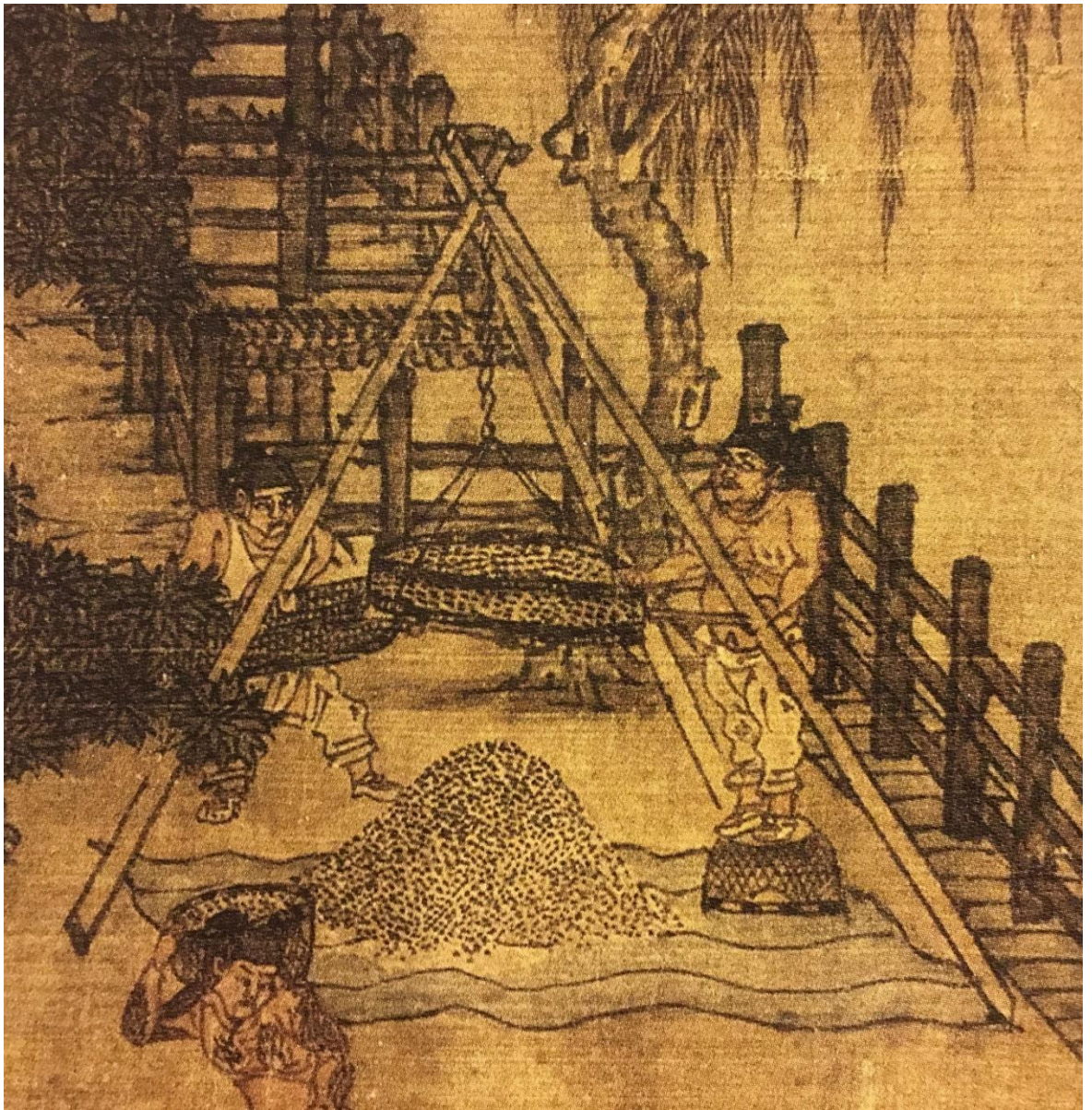


Figure 313

Detail of *The Water Mill*, the top sieve structure on the right terrace

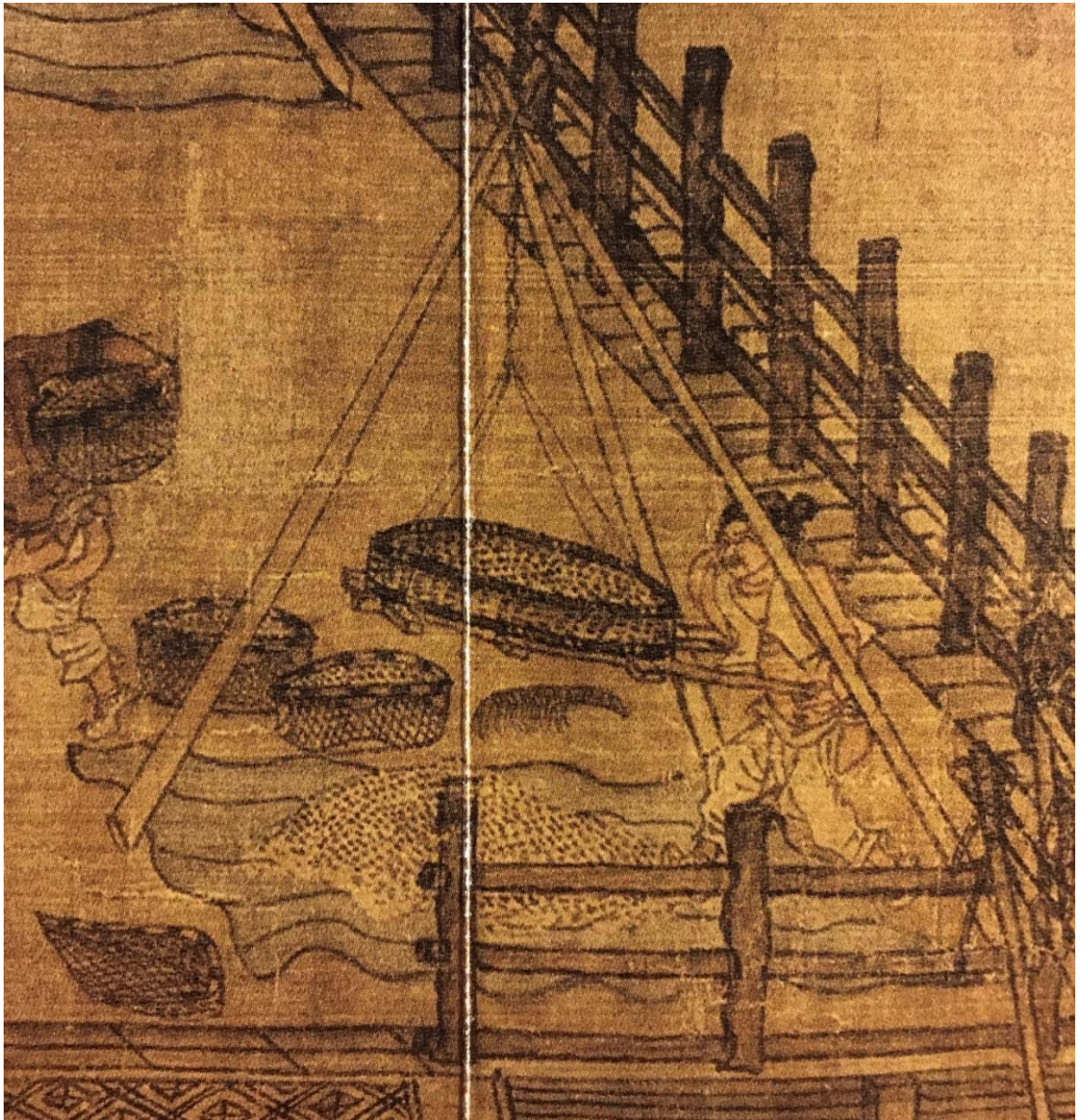


Figure 314

Detail of *The Water Mill*, the bottom sieve structure at the right terrace